

**This electronic collection of documents is provided
for the convenience of the user
and is Not a Certified Document –**

**The documents contained herein were originally issued
and sealed by the individuals whose names and license
numbers appear on each page, on the dates appearing
with their signature on that page.**

**This file or an individual page
shall not be considered a certified document.**

CONTRACT: DE00419
 TIP PROJECT: SM-5705AG
 09/08/09

See Sheet 1A For Index of Sheets
See Sheet 1B For Conventional Plan Sheet Symbols

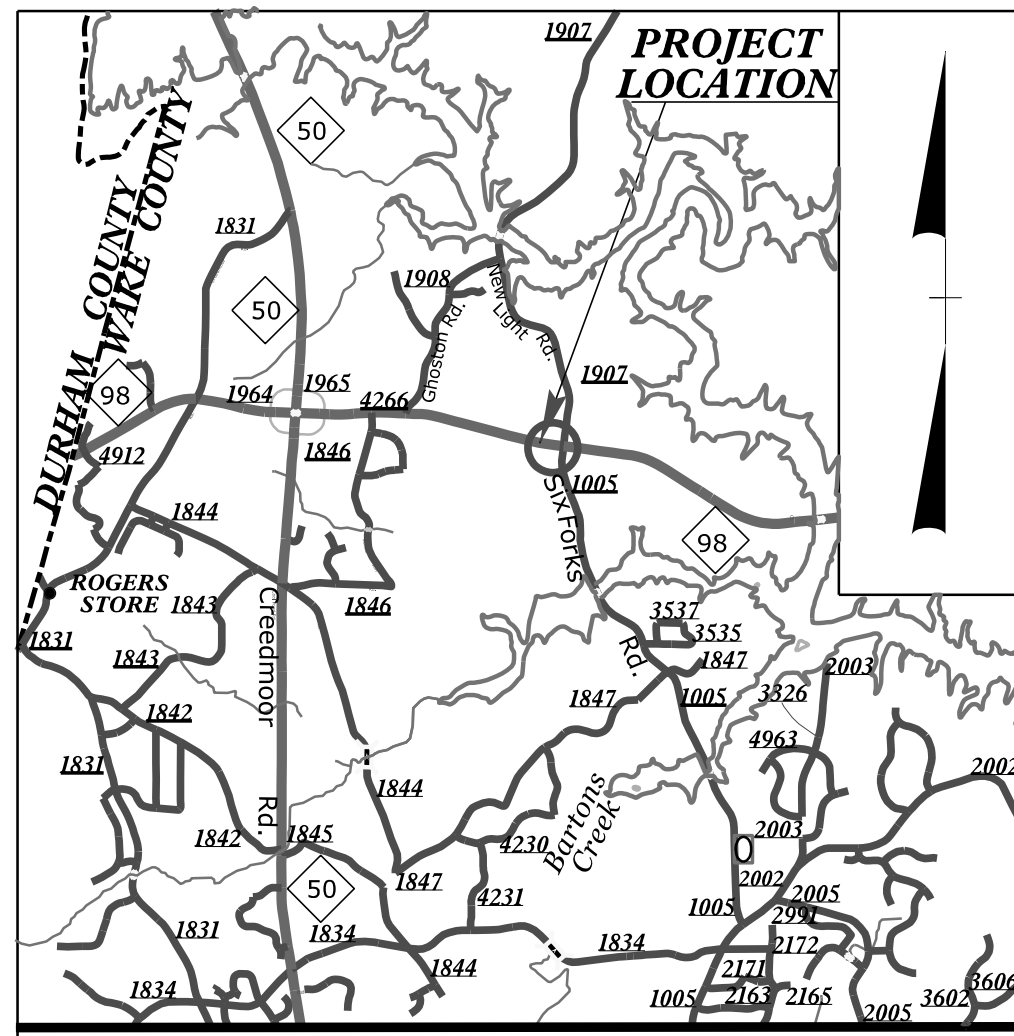

VICINITY MAP (NTS)

STATE OF NORTH CAROLINA DIVISION OF HIGHWAYS

WAKE COUNTY

LOCATION: NC 98 (DURHAM RD.) AT SR1005 (SIX FORKS RD.)

TYPE OF WORK: GRADING, DRAINAGE, PAVING, AND SIGNALS

STATE	STATE PROJECT REFERENCE NO.	SHEET NO.	TOTAL SHEETS
N.C.	SM-5705AG	1	
STATE PROJ. NO.	F. A. PROJ. NO.	DESCRIPTION	
48903.1.1		PE	
48903.2.1		R/W	
48903.3.1		CONST.	

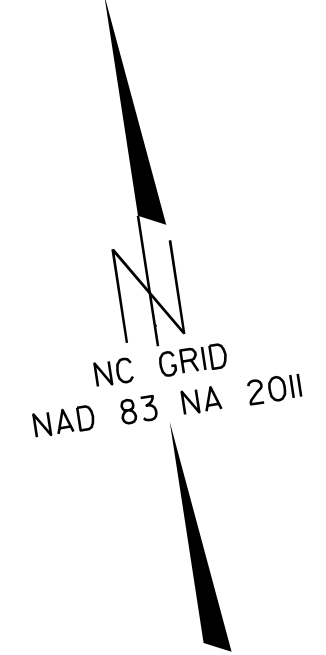
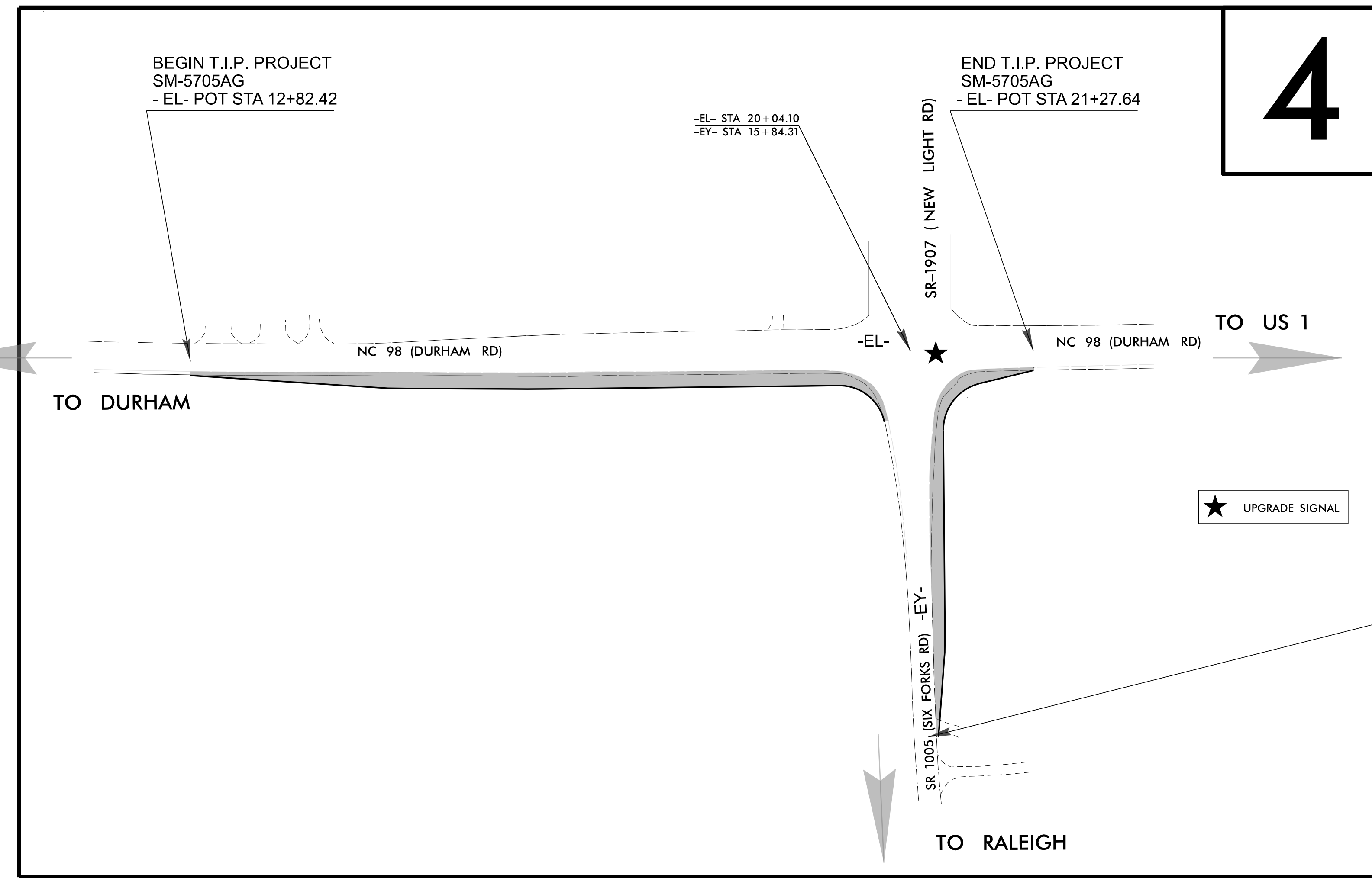

4

DOCUMENT NOT CONSIDERED FINAL
UNLESS ALL SIGNATURES COMPLETED

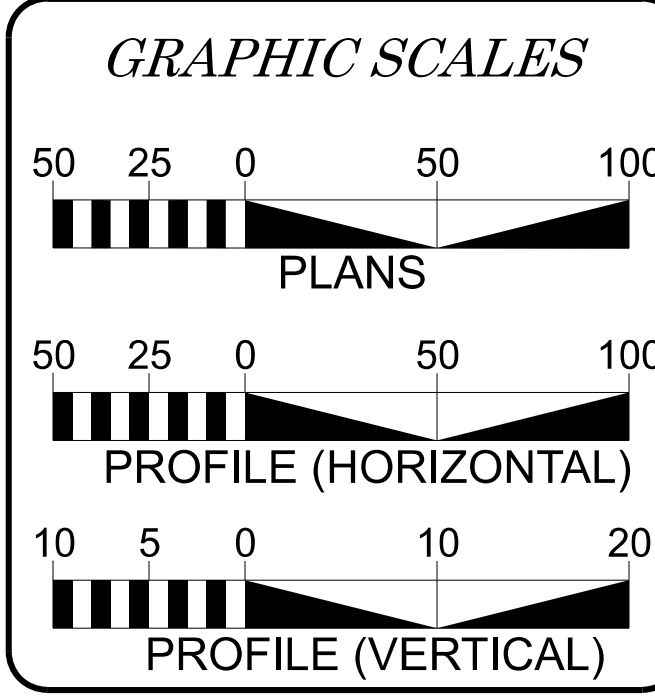

DESIGN DATA

-EL-: ADT 2026 = 21,700
 ADT 2046 = 32,600
 T = 5 %*
 V = 60 MPH
 * TTST = 4 DUAL = 1

FUNC CLASS =
 MINOR ARTERIAL

-EY-: ADT 2026 = 7,500
 ADT 2046 = 10,900
 V = 50 MPH

FUNC CLASS =
 MAJOR COLLECTOR

PROJECT LENGTH

LENGTH ROADWAY PROJECT SM-5705AG = 0.160 MILES

Prepared in the Office of:
DIVISION OF HIGHWAYS
 2612 N. Duke St., Durham, NC, 27704

2024 STANDARD SPECIFICATIONS

RIGHT OF WAY DATE:
 AUGUST 9, 2024

LETTING DATE:
 MARCH 25, 2026

MATTHEW J. NOLFO, P.E.
 PROJECT ENGINEER

SUNIL J. PATEL
 PROJECT DESIGN ENGINEER

HYDRAULICS ENGINEER

DocuSigned by:
 Erik Siler
 9140F8C205F245D
 02/18/2026

SIGNATURE: _____ P.E.

ROADWAY DESIGN ENGINEER

Signed by:
 Matthew J. Patel
 02/18/2026

SIGNATURE: _____ P.E.

STATE OF NORTH CAROLINA
 FIFTH DIVISION
 BECCA GALLAS, PE
 DIVISION ENGINEER

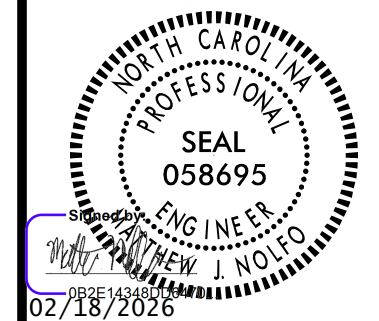

INDEX OF SHEETS

SHEET NUMBER	SHEET
1	TITLE SHEET
1A	INDEX OF SHEETS, GENERAL NOTES, AND STANDARD DRAWINGS
1B	CONVENTIONAL SYMBOLS
2A-1	PAVEMENT SCHEDULE AND TYPICAL SECTIONS
2C-1 THRU 2C-4	DETAILS IN LIEU OF STANDARDS
3B-1	ROADWAY SUMMARIES
3D-1	DRAINAGE SUMMARIES
4 THRU 6	PLAN AND PROFILE SHEETS
RW01 THRU RW04	SURVEY CONTROL & RIGHT OF WAY SHEETS
PMP-1 THRU PMP-3	SIGNING AND PAVEMENT MARKING PLANS
EC-1 THRU EC-5	EROSION CONTROL PLANS
SIG-1.0 THRU SIG-2.2	SIGNAL PLANS
UO-1 AND UO-2	UTILITIES BY OTHERS PLANS
X-1 THRU X-12	CROSS-SECTIONS

GENERAL NOTES: 2024 SPECIFICATIONS
EFFECTIVE: 01-16-2024
REVISED:

GRADING AND SURFACING OR RESURFACING AND WIDENING:

THE GRADE LINES SHOWN DENOTE THE FINISHED ELEVATION OF THE PROPOSED SURFACING AT GRADE POINTS SHOWN ON THE TYPICAL SECTIONS. WHERE NO GRADE LINES ARE SHOWN, THE PROFILES SHOWN DENOTE THE TOP ELEVATION OF THE EXISTING PAVEMENT ALONG THE CENTER LINE OF SURVEY ON WHICH THE PROPOSED RESURFACING WILL BE PLACED. GRADE LINES MAY BE ADJUSTED BY THE ENGINEER IN ORDER TO SECURE A PROPER TIE-IN.

CLEARING:

CLEARING ON THIS PROJECT SHALL BE PERFORMED TO THE LIMITS ESTABLISHED BY METHOD III.

SUPERELEVATION:

ALL CURVES ON THIS PROJECT SHALL BE SUPERELEVATED IN ACCORDANCE WITH STD. NO. 225.04 USING THE RATE OF SUPERELEVATION AND RUNOFF SHOWN ON THE PLANS. SUPERELEVATION IS TO BE REVOLVED ABOUT THE GRADE POINTS SHOWN ON THE TYPICAL SECTIONS.

SHOULDER CONSTRUCTION:

ASPHALT, EARTH, AND CONCRETE SHOULDER CONSTRUCTION ON THE HIGH SIDE OF SUPERELEVATED CURVES SHALL BE IN ACCORDANCE WITH STD. NO. 560.01

SUBSURFACE PLANS:

NO SUBSURFACE PLANS ARE AVAILABLE ON THIS PROJECT. THE CONTRACTOR SHOULD MAKE HIS OWN INVESTIGATION AS TO THE SUBSURFACE CONDITIONS.

UTILITIES:

UTILITY OWNERS ON THIS PROJECT ARE AT&T (FIBER) AND

CHARTER/SPECTRUM (FIBER)

ANY RELOCATION OF EXISTING UTILITIES WILL BE ACCOMPLISHED BY OTHERS.

RIGHT-OF-WAY MARKERS:

ALL RIGHT-OF-WAY MARKERS ON THIS PROJECT SHALL BE PLACED BY CONTRACT.

EFF. 01-16-2024
REV.

2024 ROADWAY ENGLISH STANDARD DRAWINGS

The following Roadway Standards as appear in "Roadway Standard Drawings" Contracts Standards and Development Unit - N. C. Department of Transportation - Raleigh, N. C., Dated January 16, 2024 are applicable to this project and by reference hereby are considered a part of these plans:

STD.NO.	TITLE
DIVISION 2 - EARTHWORK	
200.03	Method of Clearing - Method III
225.02	Guide for Grading Subgrade - Secondary and Local
225.04	Method of Obtaining Superelevation - Two Lane Pavement
225.06	Method of Grading Sight Distance at Intersections
DIVISION 3 - PIPE CULVERTS	
300.01	Method of Pipe Installation (Standard has a detail in lieu)
310.10	Driveway Pipe Construction
DIVISION 5 - SUBGRADE, BASES AND SHOULDERS	
560.01	Method of Shoulder Construction - High Side of Superelevated Curve - Method I
DIVISION 8 - INCIDENTALS	
806.01	Concrete Right-of-Way Marker
806.02	Granite Right-of-Way Marker
816.04	Markers for Drainage Structure and Concrete Pad (Standard has a detail in lieu)
840.17	Concrete Grated Drop Inlet Type 'A' - 12" thru 72" Pipe
840.18	Concrete Grated Drop Inlet Type 'B' - 12" thru 36" Pipe
840.22	Frames and Wide Slot Sag Grates
840.26	Brick Grated Drop Inlet Type 'A' - 12" thru 72" Pipe
840.27	Brick Grated Drop Inlet Type 'B' - 12" thru 36" Pipe
840.31	Concrete Junction Box - 12" thru 66" Pipe
840.32	Brick Junction Box - 12" thru 66" Pipe
840.54	Manhole Frame and Cover
840.72	Pipe Collar
876.02	Guide for Rip Rap at Pipe Outlets

STATE OF NORTH CAROLINA, DIVISION OF HIGHWAYS CONVENTIONAL PLAN SHEET SYMBOLS

Note: Not to Scale

BOUNDARIES AND PROPERTY:

State Line	-----
County Line	-----
Township Line	-----
City Line	-----
Reservation Line	-----
Property Line	-----
Existing Iron Pin (EIP)	○
Computed Property Corner	×
Existing Concrete Monument (ECM)	□
Parcel / Sequence Number	(23)
Existing Fence Line	-x-x-x-
Proposed Woven Wire Fence	○
Proposed Chain Link Fence	□
Proposed Barbed Wire Fence	◇
Existing Wetland Boundary	----- WLB -----
Proposed Wetland Boundary	----- WLB -----
Existing Endangered Animal Boundary	----- EAB -----
Existing Endangered Plant Boundary	----- EPB -----
Existing Historic Property Boundary	----- HPB -----
Known Contamination Area: Soil	----- S -----
Potential Contamination Area: Soil	----- S -----
Known Contamination Area: Water	----- W -----
Potential Contamination Area: Water	----- W -----
Contaminated Site: Known or Potential	☠ ☡

BUILDINGS AND OTHER CULTURE:

Gas Pump Vent or U/G Tank Cap	○
Sign	○
Well	○
Small Mine	×
Foundation	□
Area Outline	□
Cemetery	□
Building	□
School	□
Church	□
Dam	-----

HYDROLOGY:

Stream or Body of Water	-----
Hydro, Pool or Reservoir	-----
Jurisdictional Stream	----- JS -----
Buffer Zone 1	----- BZ 1 -----
Buffer Zone 2	----- BZ 2 -----
Flow Arrow	←
Disappearing Stream	-----
Spring	-----
Wetland	-----
Proposed Lateral, Tail, Head Ditch	-----
False Sump	-----

RAILROADS:

Standard Gauge	-----
RR Signal Milepost	○
Switch	□
RR Abandoned	-----
RR Dismantled	-----

RIGHT OF WAY & PROJECT CONTROL:

Primary Horiz Control Point	○
Primary Horiz and Vert Control Point	●
Secondary Horiz and Vert Control Point	◆
Vertical Benchmark	⊠
Existing Right of Way Monument	△
Proposed Right of Way Monument (Rebar and Cap)	▲
Proposed Right of Way Monument (Concrete)	▲
Existing Permanent Easement Monument	◇
Proposed Permanent Easement Monument (Rebar and Cap)	◆
Existing C/A Monument	△
Proposed C/A Monument (Rebar and Cap)	▲
Proposed C/A Monument (Concrete)	▲
Existing Right of Way Line	-----
Proposed Right of Way Line	-----
Existing Control of Access Line	-----
Proposed Control of Access Line	-----
Proposed ROW and CA Line	-----
Existing Easement Line	-----
Proposed Temporary Construction Easement	-----
Proposed Temporary Drainage Easement	-----
Proposed Permanent Drainage Easement	-----
Proposed Permanent Drainage/Utility Easement	-----
Proposed Permanent Utility Easement	-----
Proposed Temporary Utility Easement	-----
Proposed Aerial Utility Easement	-----

ROADS AND RELATED FEATURES:

Existing Edge of Pavement	-----
Existing Curb	-----
Proposed Slope Stakes Cut	-----
Proposed Slope Stakes Fill	-----
Proposed Curb Ramp	-----
Existing Metal Guardrail	-----
Proposed Guardrail	-----
Existing Cable Guiderail	-----
Proposed Cable Guiderail	-----
Equality Symbol	⊕
Pavement Removal	-----
VEGETATION:	
Single Tree	○
Single Shrub	○
Hedge	-----

Woods Line	-----
Orchard	-----
Vineyard	-----

EXISTING STRUCTURES:

MAJOR:	
Bridge, Tunnel or Box Culvert	-----
Bridge Wing Wall, Head Wall and End Wall	-----
MINOR:	
Head and End Wall	-----
Pipe Culvert	-----
Footbridge	-----
Drainage Box: Catch Basin, DI or JB	-----
Paved Ditch Gutter	-----
Storm Sewer Manhole	-----
Storm Sewer	-----

UTILITIES:

* SUE - Subsurface Utility Engineering
LOS - Level of Service - A,B,C or D (Accuracy)

POWER:	
Existing Power Pole	●
Proposed Power Pole	○
Existing Joint Use Pole	●
Proposed Joint Use Pole	○
Power Manhole	⊕
Power Line Tower	⊠
Power Transformer	⊠
U/G Power Cable Hand Hole	⊠
H-Frame Pole	●
U/G Power Line Test Hole (SUE - LOS A)*	⊕
U/G Power Line (SUE - LOS B)*	-----
U/G Power Line (SUE - LOS C)*	-----
U/G Power Line (SUE - LOS D)*	-----

TELEPHONE:

Existing Telephone Pole	●
Proposed Telephone Pole	○
Telephone Manhole	⊕
Telephone Pedestal	⊠
Telephone Cell Tower	⊠
U/G Telephone Cable Hand Hole	⊠
U/G Telephone Test Hole (SUE - LOS A)*	⊕
U/G Telephone Cable (SUE - LOS B)*	-----
U/G Telephone Cable (SUE - LOS C)*	-----
U/G Telephone Cable (SUE - LOS D)*	-----
U/G Telephone Conduit (SUE - LOS B)*	-----
U/G Telephone Conduit (SUE - LOS C)*	-----
U/G Telephone Conduit (SUE - LOS D)*	-----
U/G Fiber Optics Cable (SUE - LOS B)*	-----
U/G Fiber Optics Cable (SUE - LOS C)*	-----
U/G Fiber Optics Cable (SUE - LOS D)*	-----

WATER:	
Water Manhole	⊕
Water Meter	○
Water Valve	⊗
Water Hydrant	⊕
U/G Water Line Test Hole (SUE - LOS A)*	⊕
U/G Water Line (SUE - LOS B)*	-----
U/G Water Line (SUE - LOS C)*	-----
U/G Water Line (SUE - LOS D)*	-----
Above Ground Water Line	-----
TV:	
TV Pedestal	⊠
TV Tower	⊗
U/G TV Cable Hand Hole	⊠
U/G TV Test Hole (SUE - LOS A)*	⊕
U/G TV Cable (SUE - LOS B)*	-----
U/G TV Cable (SUE - LOS C)*	-----
U/G TV Cable (SUE - LOS D)*	-----
U/G Fiber Optic Cable (SUE - LOS B)*	-----
U/G Fiber Optic Cable (SUE - LOS C)*	-----
U/G Fiber Optic Cable (SUE - LOS D)*	-----
GAS:	
Gas Valve	◇
Gas Meter	⊕
U/G Gas Line Test Hole (SUE - LOS A)*	⊕
U/G Gas Line (SUE - LOS B)*	-----
U/G Gas Line (SUE - LOS C)*	-----
U/G Gas Line (SUE - LOS D)*	-----
Above Ground Gas Line	-----
SANITARY SEWER:	
Sanitary Sewer Manhole	⊕
Sanitary Sewer Cleanout	⊕
U/G Sanitary Sewer Line	-----
Above Ground Sanitary Sewer	-----
SS Force Main Line Test Hole (SUE - LOS A)*	⊕
SS Force Main Line (SUE - LOS B)*	-----
SS Force Main Line (SUE - LOS C)*	-----
SS Force Main Line (SUE - LOS D)*	-----
MISCELLANEOUS:	
Utility Pole	●
Utility Pole with Base	⊠
Utility Located Object	○
Utility Traffic Signal Box	⊠
Utility Unknown U/G Line (SUE - LOS B)*	-----
U/G Tank; Water, Gas, Oil	-----
Underground Storage Tank, Approx. Loc.	-----
A/G Tank; Water, Gas, Oil	-----
Geoenvironmental Boring	⊕
Abandoned According to Utility Records	-----
End of Information	-----

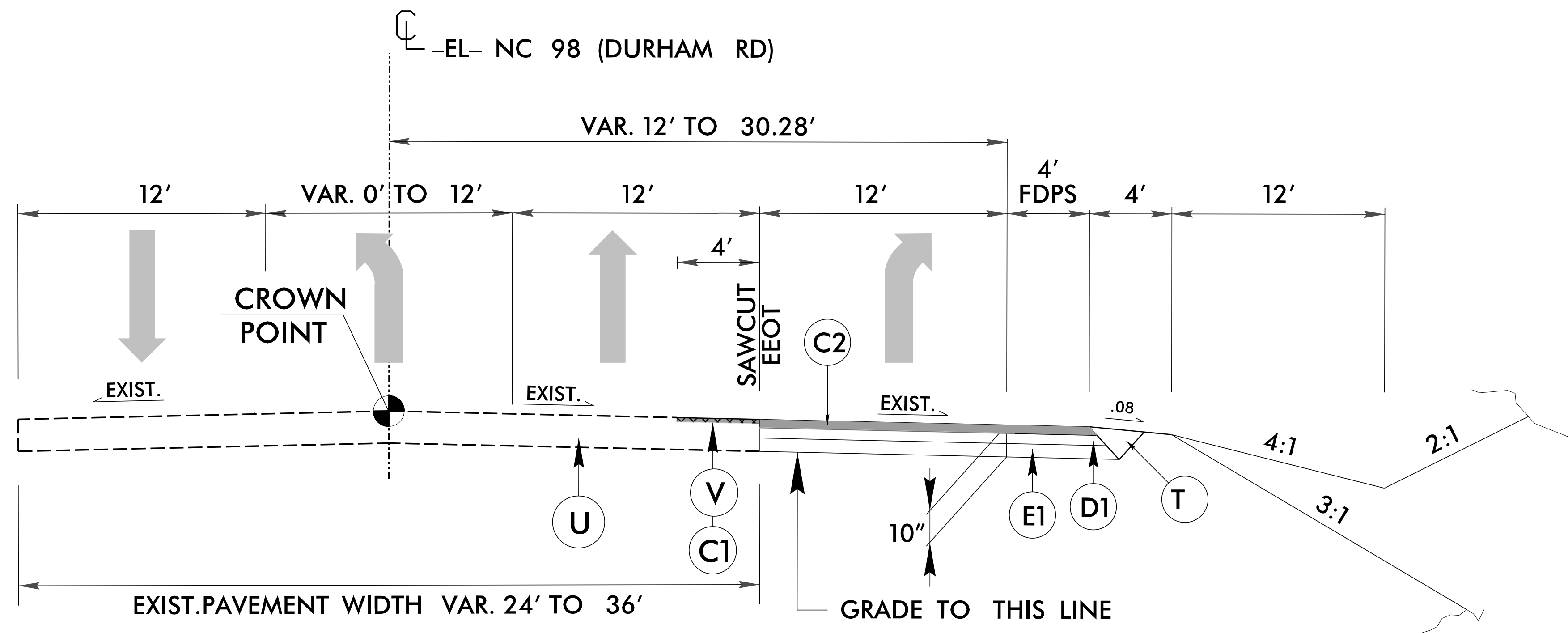
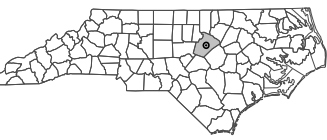

TYPICAL SECTION NO. 1
-EL- STA. 12+82.42 TO 19+32.11

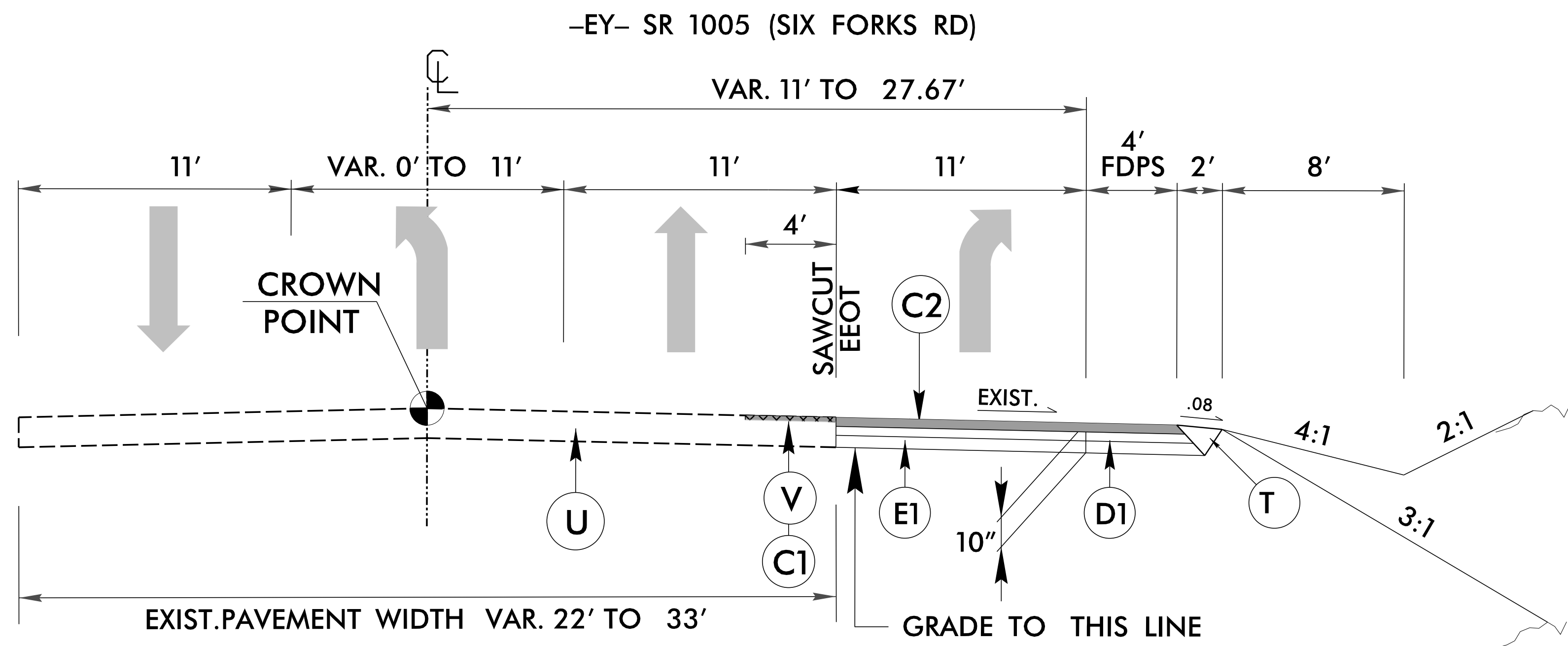

TYPICAL SECTION NO. 2
-EY- STA. 11+95.86 TO 15+50.03



PAVEMENT SCHEDULE	
C1	PROP. APPROX. 1.5" ASPHALT CONC. SURFACE COURSE, TYPE S9.5C, AT AN AVERAGE RATE OF 168 LBS. PER SQ. YD.
C2	PROP. APPROX. 3" ASPHALT CONC. SURFACE COURSE, TYPE S9.5C, AT AN AVERAGE RATE OF 168 LBS. PER SQ. YD. IN EACH OF TWO LAYERS
D1	PROP. APPROX. 3" ASPHALT CONCRETE INTERMEDIATE COURSE, TYPE I19.0C, AT AN AVERAGE RATE OF 342 LBS. PER SQ. YD.
E1	PROP. APPROX. 4" ASPHALT CONC. BASE COURSE, TYPE B25.0C, AT AN AVERAGE RATE OF 456 LBS. PER SQ. YD.
T	EARTH MATERIAL.
U	EXISTING PAVEMENT.
V	1.5" MILLING.

- NOTES:**
- 1) THE PORTION OF EACH EXISTING PAVED SHOULDER THAT IS NOT FULL DEPTH IS TO BE REMOVED AND PAVED TO FULL DEPTH.
 - 2) PAVEMENT EDGE SLOPES ARE 1:1 UNLESS SHOWN OTHERWISE.
 - 3) SEE PLANS FOR LOCATIONS OF TURN LANES AND TAPERS.
 - 4) SEE PLANS FOR RADII TURNOUTS AT INTERSECTIONS.

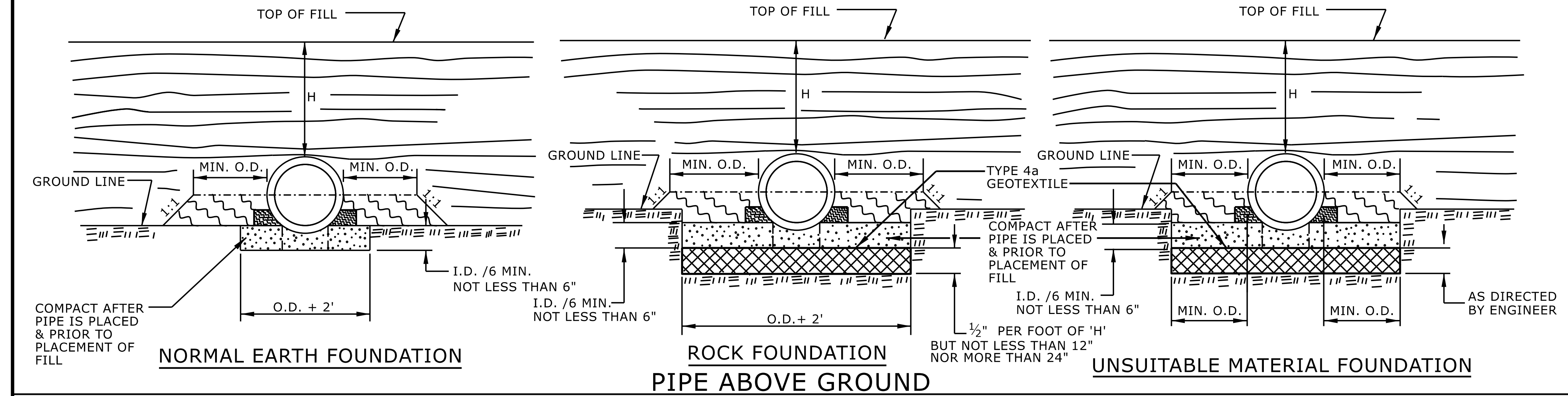
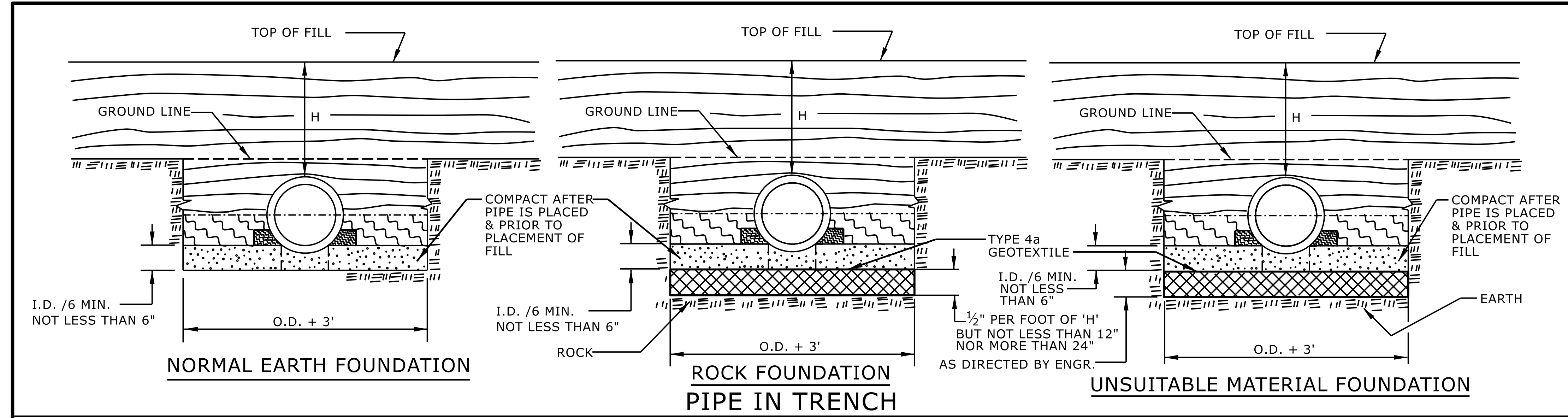



REVISIONS

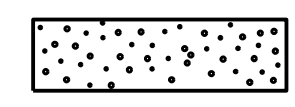

GENERAL NOTES:
 I.D. = THE MAXIMUM HORIZONTAL INSIDE DIAMETER DIMENSION.
 O.D. = THE MAXIMUM HORIZONTAL OUTSIDE DIAMETER DIMENSION.
 H = THE FILL HEIGHT MEASURED VERTICALLY AT ANY POINT ALONG THE PIPE FROM THE TOP OF THE PIPE TO THE TOP OF THE EMBANKMENT AT THAT POINT.

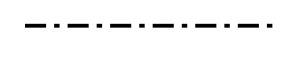
 APPROVED SUITABLE LOCAL MATERIAL.
 TAKE CARE TO FULLY COMPACT HAUNCH ZONE OF PIPE BACKFILL.
 LOOSELY PLACED SELECT MATERIAL CLASS III OR CLASS II, TYPE 1 FOR PIPE BEDDING. LEAVE SECTION DIRECTLY BENEATH PIPE UNCOMPACTED AS PIPE SEATING AND BACKFILL WILL ACCOMPLISH COMPACTION.

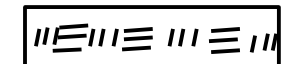
DO NOT OPERATE HEAVY EQUIPMENT OVER ANY PIPE CULVERT UNTIL THE PIPE CULVERT HAS BEEN PROPERLY BACKFILLED AND COVERED WITH AT LEAST 3 FEET OF APPROVED MATERIAL.
 REFER TO NCDOT PIPE MATERIAL SELECTION GUIDE AND STANDARD SPECIFICATIONS FOR ALLOWABLE PIPE FILL HEIGHTS AND PIPE SPECIFICATIONS.

-  SPRINGLINE OF PIPE
-  SELECT BACKFILL MATERIAL CLASS III OR CLASS II, BELOW SPRINGLINE.
-  UNDISTURBED EARTH MATERIAL
-  SELECT MATERIAL CLASS V OR VI FOR FOUNDATION CONDITIONING. ENCAPSULATE WITH TYPE IV GEOTEXTILE AS DIRECTED BY THE ENGINEER.

STATE OF NORTH CAROLINA
 DEPT. OF TRANSPORTATION
 DIVISION OF HIGHWAYS
 RALEIGH, N.C.

ROADWAY DETAIL DRAWING FOR
METHOD OF PIPE INSTALLATION
 RIGID PIPE



Signed by:
 Nicole M. Hacker
 008420334104CS
 12/16/2025

SHEET 2 OF 2
300.01

DOCUMENT NOT CONSIDERED FINAL
 UNLESS ALL SIGNATURES COMPLETED

CONTRACTS STANDARDS AND DEVELOPMENT UNIT
 Office 919-707-6950 FAX 919-250-4119

SEE TITLE BLOCK

ORIGINAL BY: S.CALHOUN DATE: 7-25-2024
 MODIFIED BY: DATE: _____
 CHECKED BY: DATE: _____
 FILE SPEC.: _____

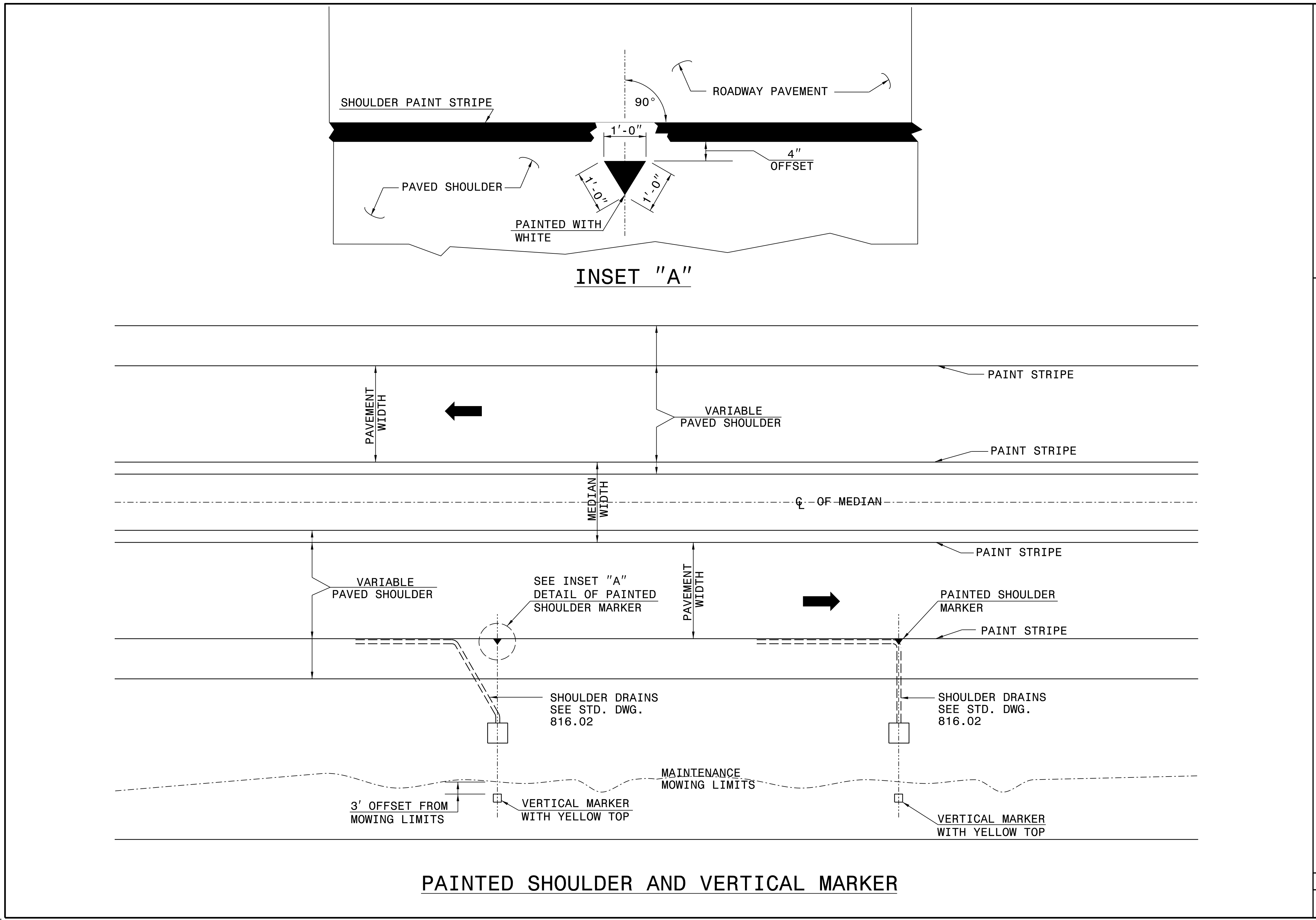

STATE OF
NORTH CAROLINA
DEPT. OF TRANSPORTATION
DIVISION OF HIGHWAYS
RALEIGH, N.C.

ROADWAY DETAIL DRAWING FOR
**MARKERS FOR DRAINAGE STRUCTURE
AND CONCRETE PAD**

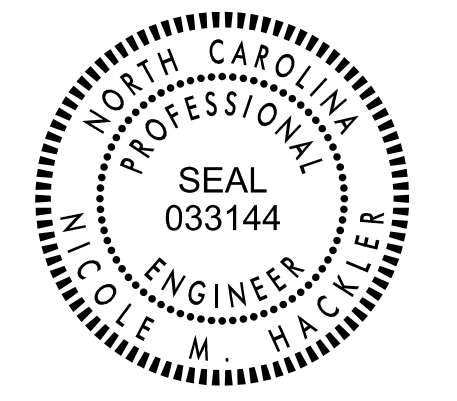

Signed by:
Nicole M. Hacker
588432034164CS
12/16/2025

SHEET 1 OF 2
816D04

DOCUMENT NOT CONSIDERED FINAL
UNLESS ALL SIGNATURES COMPLETED

CONTRACTS STANDARDS
AND DEVELOPMENT UNIT
Office 919-707-6950 FAX 919-250-4119

SEE TITLE BLOCK

ORIGINAL BY: K. Aldridge DATE: 06-02-2025
 MODIFIED BY: _____ DATE: _____
 CHECKED BY: _____ DATE: _____
 FILE SPEC.: _____

NOTES:

- DESIGN CONFORMS WITH THE SPECIFICATIONS FOR THE DESIGN AND CONSTRUCTION OF STRUCTURAL SUPPORTS FOR HIGHWAY SIGNS - AASHTO.
- USE MATERIALS, FABRICATE AND ERECT SIGNS AND SUPPORTS THAT CONFORM TO THE NORTH CAROLINA DEPARTMENT OF TRANSPORTATION STANDARD SPECIFICATIONS FOR ROADS AND STRUCTURES.
- USE HIGH STRENGTH BOLTS, NUTS AND WASHERS THAT CONFORM TO ASTM A-325 AND THAT ARE GALVANIZED IN ACCORDANCE WITH ASTM F2329 OR B695 CLASS 55.
- USE BACKING PLATES, SLIP BASE PLATES, FRICTION PLATES, AND HINGE PLATES THAT CONFORM TO ASTM A-36 AND THAT ARE GALVANIZED IN ACCORDANCE WITH ASTM A-123 PRIOR TO GALVANIZING, GRIND SMOOTH ANY METAL PROJECTION BEYOND THE PLATE FACE. KEEPER PLATES SHALL BE MANUFACTURED FROM 28 GAUGE SHEET STEEL THAT CONFORMS TO ASTM A-36 AND IS GALVANIZED IN ACCORDANCE WITH ASTM A-123
- ASSEMBLE HINGE CONNECTIONS IN THE SHOP. THE SHOP SHALL TIGHTEN BOLTS BY USE OF EITHER A CALIBRATED POWER WRENCH OR A MANUAL TORQUE WRENCH. TIGHTEN EACH HINGE CONNECTION BOLT TO 1/3 PAST SNUG.
- BASE PLATES DETAILS ARE FOR INSTALLATIONS ON THE RIGHT SHOULDER AND IN GORE AREAS.
- ASSEMBLE UPPER SUPPORT TO STUB AS SHOWN IN DETAIL. SLIP BASE PLATES SHALL BE FILLET WELDED ONTO SUPPORTS ALL AROUND THE STRUCTURAL SHAPE SO AS TO INSURE NO LOSS OF STRENGTH. ASSEMBLE IN EITHER SHOP OR FIELD. 28 GAUGE KEEPER PLATE IS PLACED BETWEEN SLIP BASE PLATES TO PREVENT BOLT SLIPPING. TIGHTEN BOLTS TO THE FOLLOWING PRESCRIBED TORQUE:

BOLT DIAMETER	TORQUE (LB. FT.)
1/2"	9
5/8"	22
3/4"	37
1"	48

- COMPLETELY ASSEMBLE BREAKAWAY SUPPORTS PRIOR TO ERECTION. BREAKAWAY SUPPORT TO BE SET IN ONE PIECE. AFTER SUPPORT HAS BEEN ERECTED AND THE CONCRETE FOOTINGS HAS CURED AT LEAST 48 HOURS, CLEAN CONCRETE FROM BASE CONNECTION BOLTS THEN LOOSEN AND RE TIGHTEN EACH BOLT IN A SYSTEMATIC ORDER TO THE PRESCRIBED TORQUE. DO NOT OVER TIGHTEN. BURR ALL BOLT THREADS OF BASE CONNECTIONS TO PREVENT LOOSENING.
- ELIMINATE HINGE CONNECTION FOR ALL SINGLE SUPPORT SIGNS.
 - DETAIL IS FOR ONE DIRECTION BREAKAWAY. WHEN PLANS REQUIRE A TWO DIRECTION BREAKAWAY, TWO FRICTION PLATES SHALL BE USED IN LIEU OF ONE FRICTION PLATE AND ONE HINGE PLATE.

STATE OF
NORTH CAROLINA
DEPT. OF TRANSPORTATION
DIVISION OF HIGHWAYS
RALEIGH, N.C.

ROADWAY DETAIL DRAWING FOR
GROUND MOUNTED SIGN SUPPORTS

SHEET 3 OF 3
903D1003



Signed by:
Matthew V. Springer, PE
12/16/2025

**CONTRACTS STANDARDS
AND DEVELOPMENT UNIT**
Office 919-707-8950 FAX 919-250-4119

SEE TITLE BLOCK

ORIGINAL BY: **R.S. GALLO** DATE: **05-22-2025**
MODIFIED BY: DATE:
CHECKED BY: DATE:
FILE SPEC.:

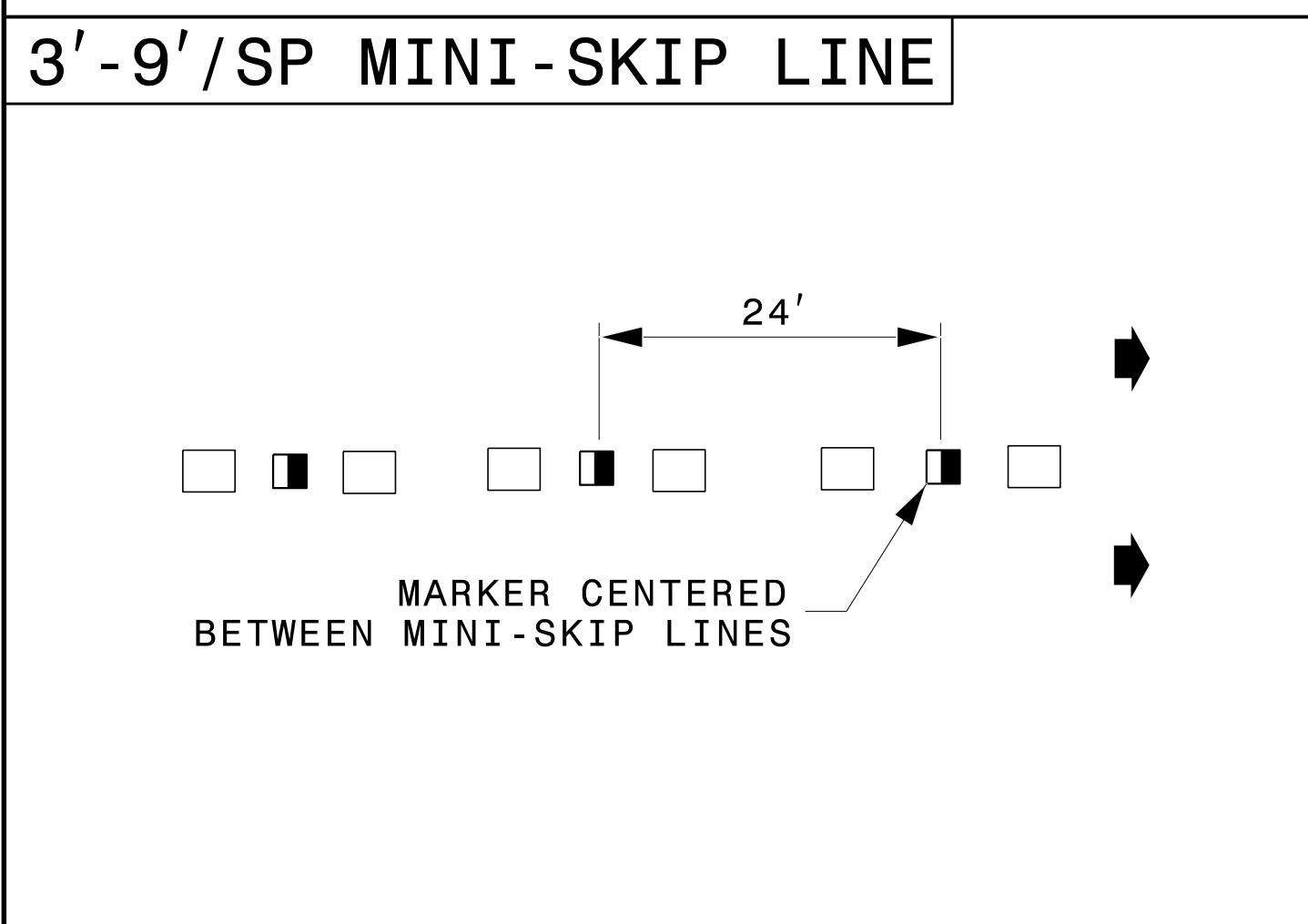
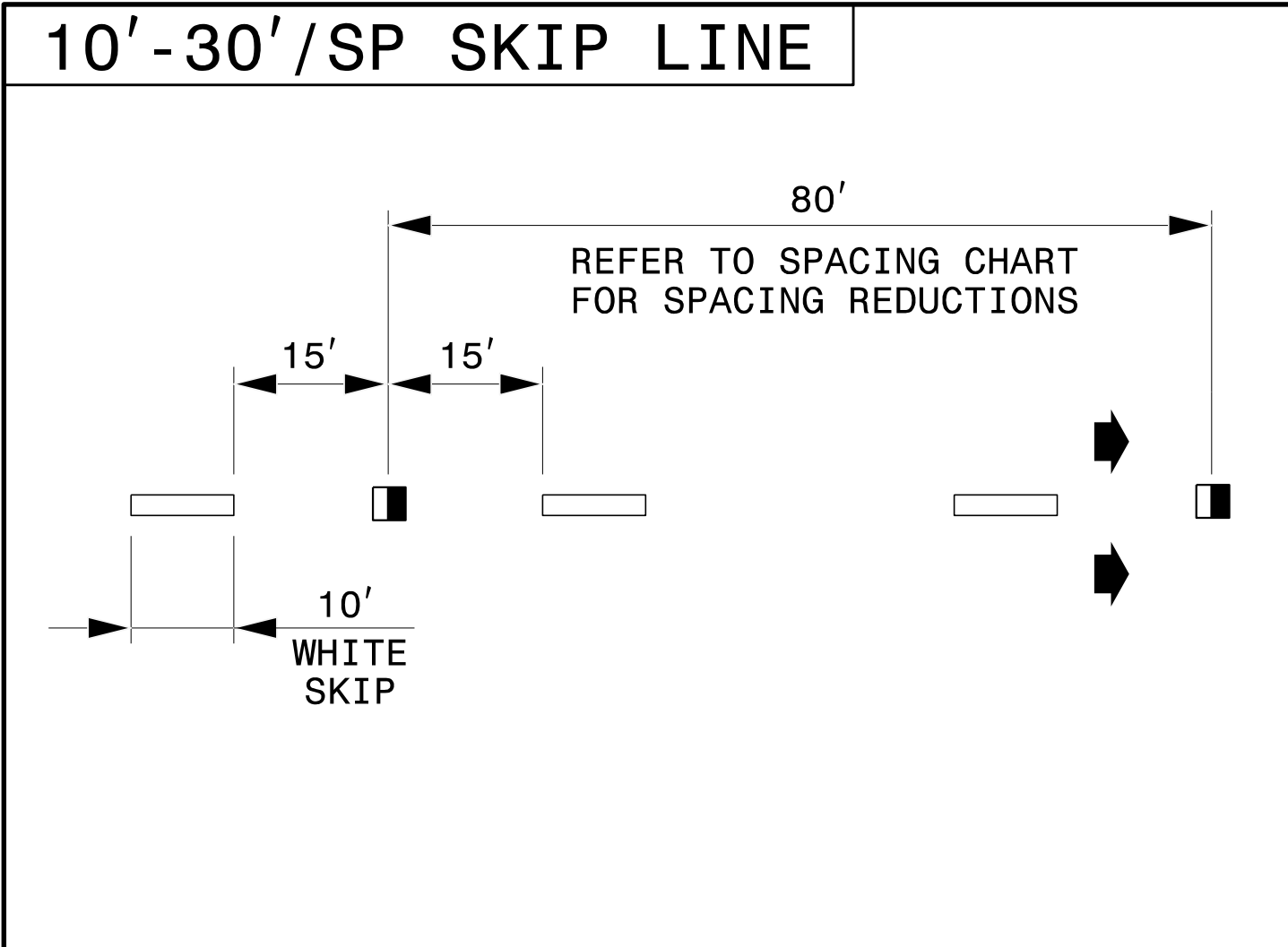

LEGEND	
	CRYSTAL/RED PAVEMENT MARKER
	YELLOW/YELLOW PAVEMENT MARKER
	DIRECTION OF TRAFFIC FLOW

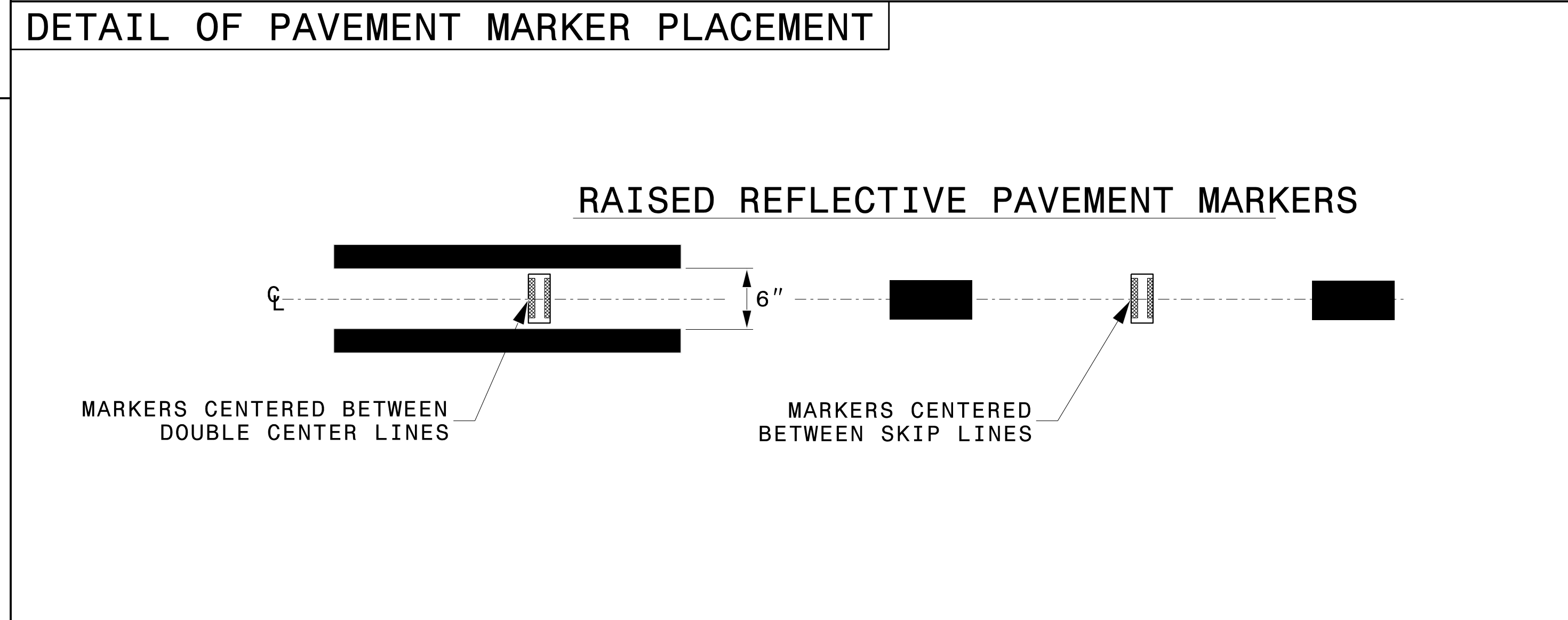
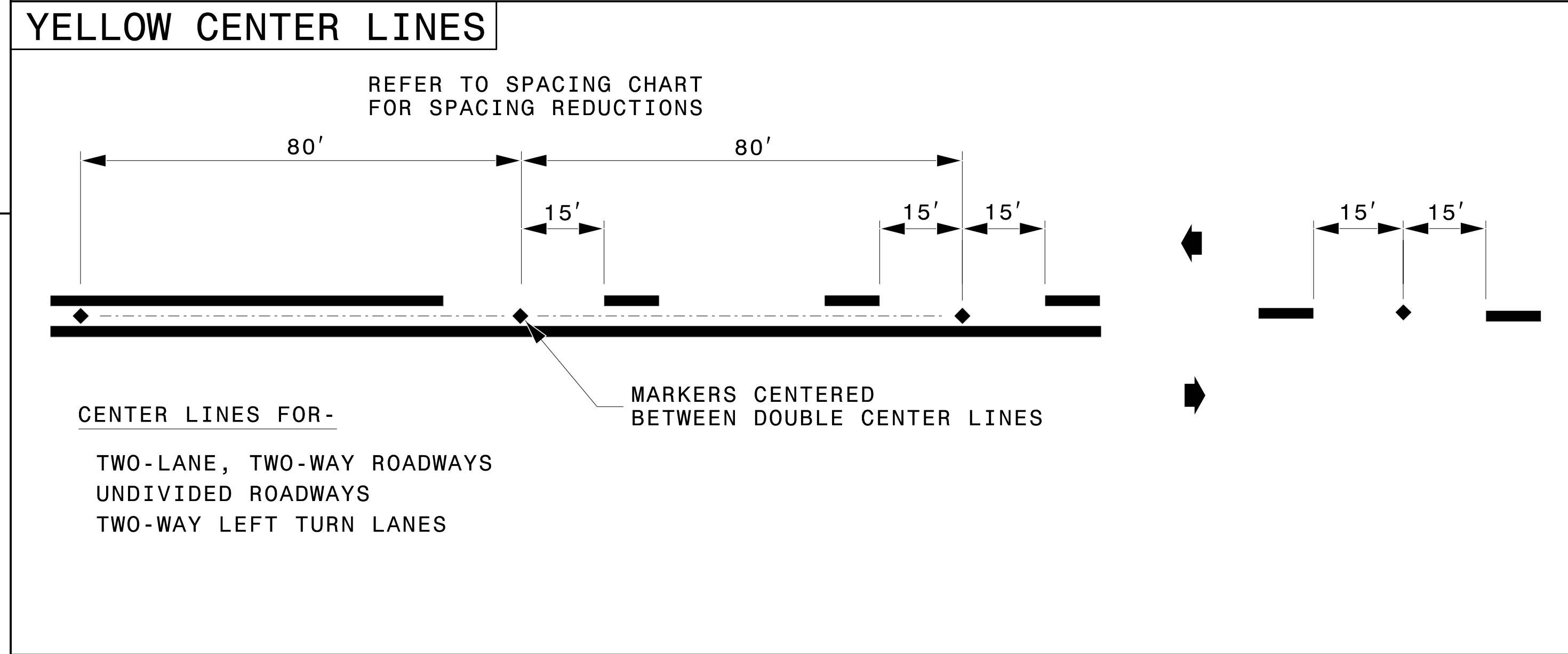
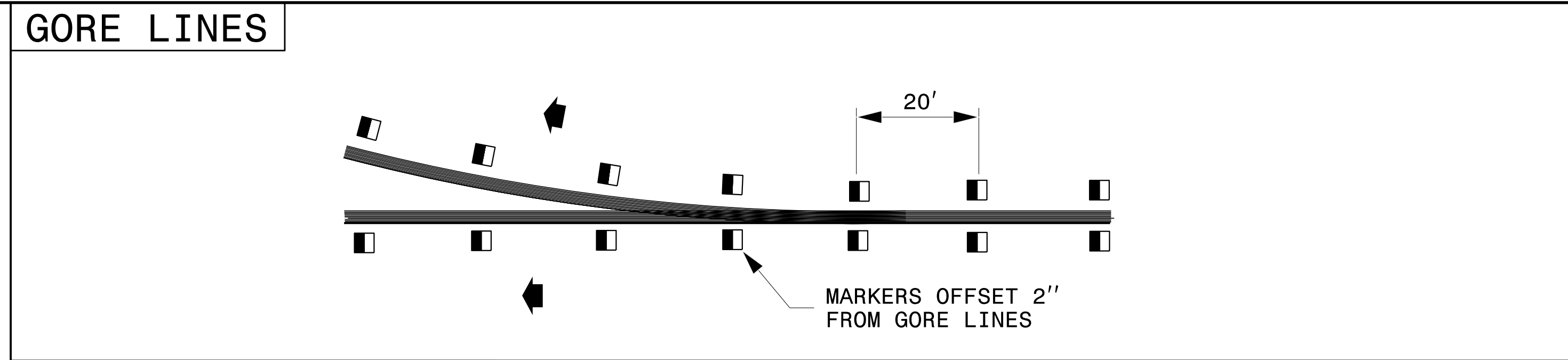

STATE OF
NORTH CAROLINA
DEPT. OF TRANSPORTATION
DIVISION OF HIGHWAYS
RALEIGH, N.C.

ROADWAY DETAIL DRAWING FOR
RAISED PAVEMENT MARKERS
INSTALLATION SPACING

SHEET 2 OF 3
1250D01



Signed by:
Matthew V. Springer, PE
12/16/2025

CONTRACTS STANDARDS
AND DEVELOPMENT UNIT
Office 919-707-8950 FAX 919-250-4119

SEE TITLE BLOCK

ORIGINAL BY: M.V. SPRINGER DATE: 2-15-24
MODIFIED BY: DATE: _____
CHECKED BY: DATE: _____
FILE SPEC.: _____

5/26/20

COMPUTED BY: LC DATE: 4/03/2024
 CHECKED BY: THOMAS R MEADOWS DATE: 5/03/2024

STATE OF NORTH CAROLINA DIVISION OF HIGHWAYS

SUMMARY OF EARTHWORK

IN CUBIC YARDS

COUNTY: WAKE

LOCATION STATION TO STATION	UNCLASSIFIED EXCAVATION	EMBT + 20%	BORROW	WASTE
-EL- 12 + 82.42 TO 19 + 80.99	615	401	0	214
SUBTOTALS No. 1	615	401	0	214
-EY- 11 + 95.86 TO -EL- 21 + 27.64	65	1,097	1,047	15
SUBTOTALS No. 2	65	1,097	1,047	15
PROJECT SUBTOTALS	680	1,498	1,047	229
WASTE IN LIEU OF BORROW	0	0	-229	0
PROJECT TOTALS			818	
EST. 5% TO REPLACE TOP SOIL ON BORROW PIT			41	-229
GRAND TOTALS	680	1,498	859	0
SAY	700		880	

SHALLOW UNDERCUT: 150 CY
 CLASS IV STABILIZATION: 300 TONS

Note: Approximate quantities only. Unclassified Excavation, Borrow Excavation, Shoulder Borrow, Fine Grading, Clearing and Grubbing, Breaking of Existing Pavement, and Removal of Existing Pavement will be paid for at the contract lump sum price for "Grading."

HY-202018L

COMPUTED BY: SJM DATE: 28May2024
CHECKED BY: DATE:

NORTH CAROLINA DEPARTMENT OF TRANSPORTATION
DIVISION OF HIGHWAYS

PROJECT NO. SM-5705AG
SHEET NO. 3D-1

Note: Invert Elevations indicated are for Bid Purposes only and shall not be used for project construction stakeout.
See "Standard Specifications For Roads and Structures, Section 300-5".

LIST OF PIPES, ENDWALLS, ETC. (FOR PIPES 48 INCHES & UNDER)

Table with columns: LINE & STATION, SIZE, THICKNESS OR GAUGE, OFFSET, STRUCTURE NUMBER, TOP ELEVATION, INVERT ELEVATION, MINIMUM REQUIRED SLOPE, R. C. PIPE CLASS IV, ENDWALLS, REINFORCED ENDWALLS, MASONRY, QUANTITIES FOR DRAINAGE STRUCTURES, FRAME, GRATES, AND HOOD, CONCRETE TRANSITIONAL SECTION, and REMARKS. Includes summary rows for SHEET TOTALS and PROJECT TOTALS.



CUR DATA -EL-
Pc 12+07.36
 $\Delta c = 02^{\circ}39'31.9''$ (LT)
 $D = 01^{\circ}38'28.2''$
 $Lc = 162.01$
 $Tc = 81.02$
 $R = 3,491.18$

CUR DATA -EL-
Pc 14+15.82
 $\Delta c = 01^{\circ}11'55.0''$ (LT)
 $D = 03^{\circ}08'04.2''$
 $Lc = 38.24$
 $Tc = 19.12$
 $R = 1,827.91$

BEGIN TIP PROJECT
SM-5705AG
-EL- STA. 12 + 82.42

END TIP PROJECT
SM-5705AG
-EL- STA. 21 + 27.64

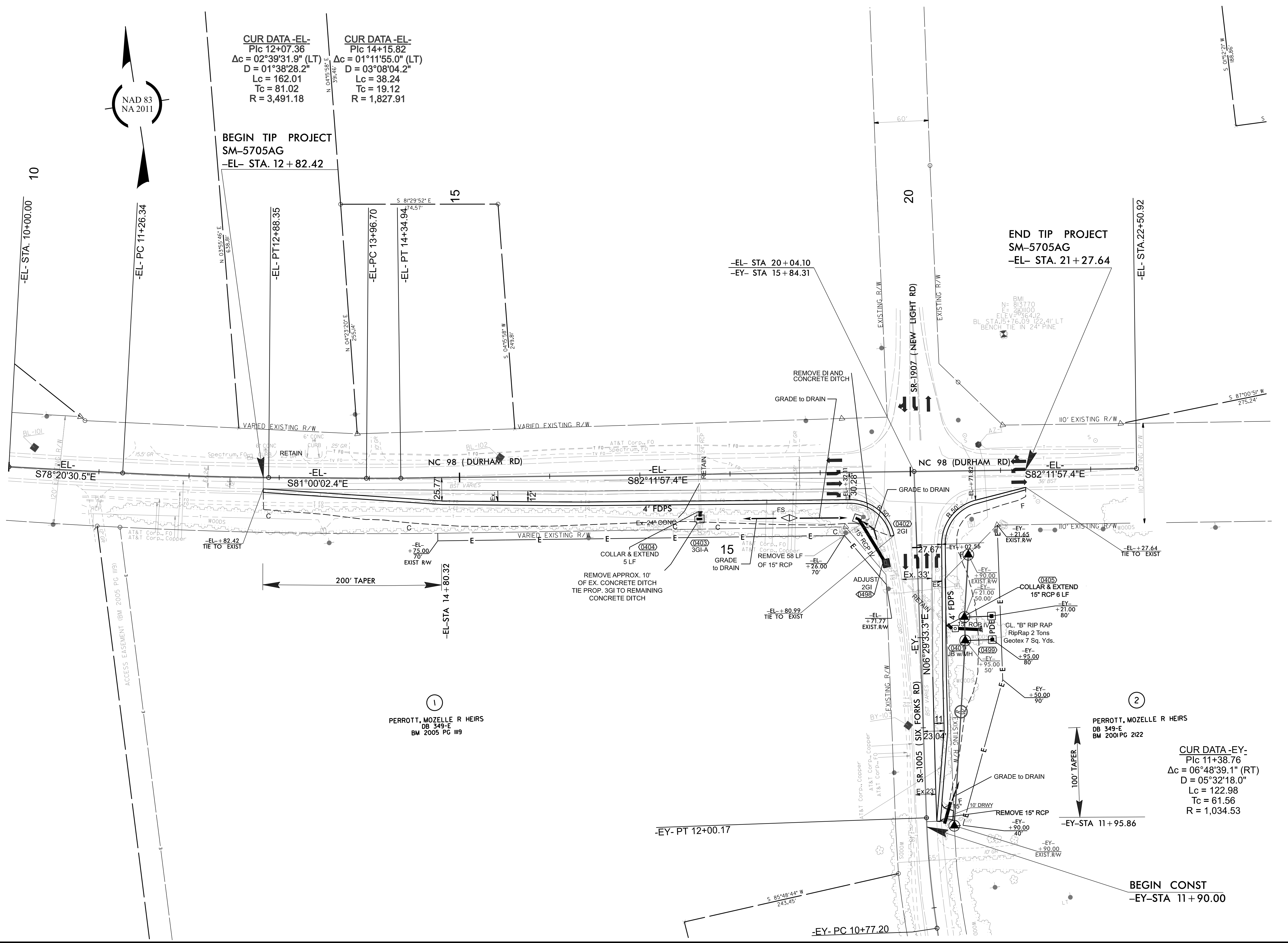

ACCESS EASEMENT (BM 2005 PG 119)

PERROTT, MOZELLE R HEIRS
DB 349-E
BM 2005 PG 119

PERROTT, MOZELLE R HEIRS
DB 349-E
BM 2001 PG 212

CUR DATA -EY-
Pc 11+38.76
 $\Delta c = 06^{\circ}48'39.1''$ (RT)
 $D = 05^{\circ}32'18.0''$
 $Lc = 122.98$
 $Tc = 61.56$
 $R = 1,034.53$

BEGIN CONST
-EY- STA. 11 + 90.00

REVISIONS



DOCUMENT NOT CONSIDERED FINAL
UNLESS ALL SIGNATURES COMPLETED
12/22/2025

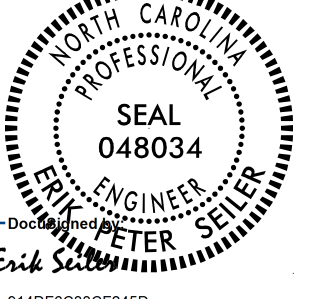

914DF033CF245D...
12/22/2025

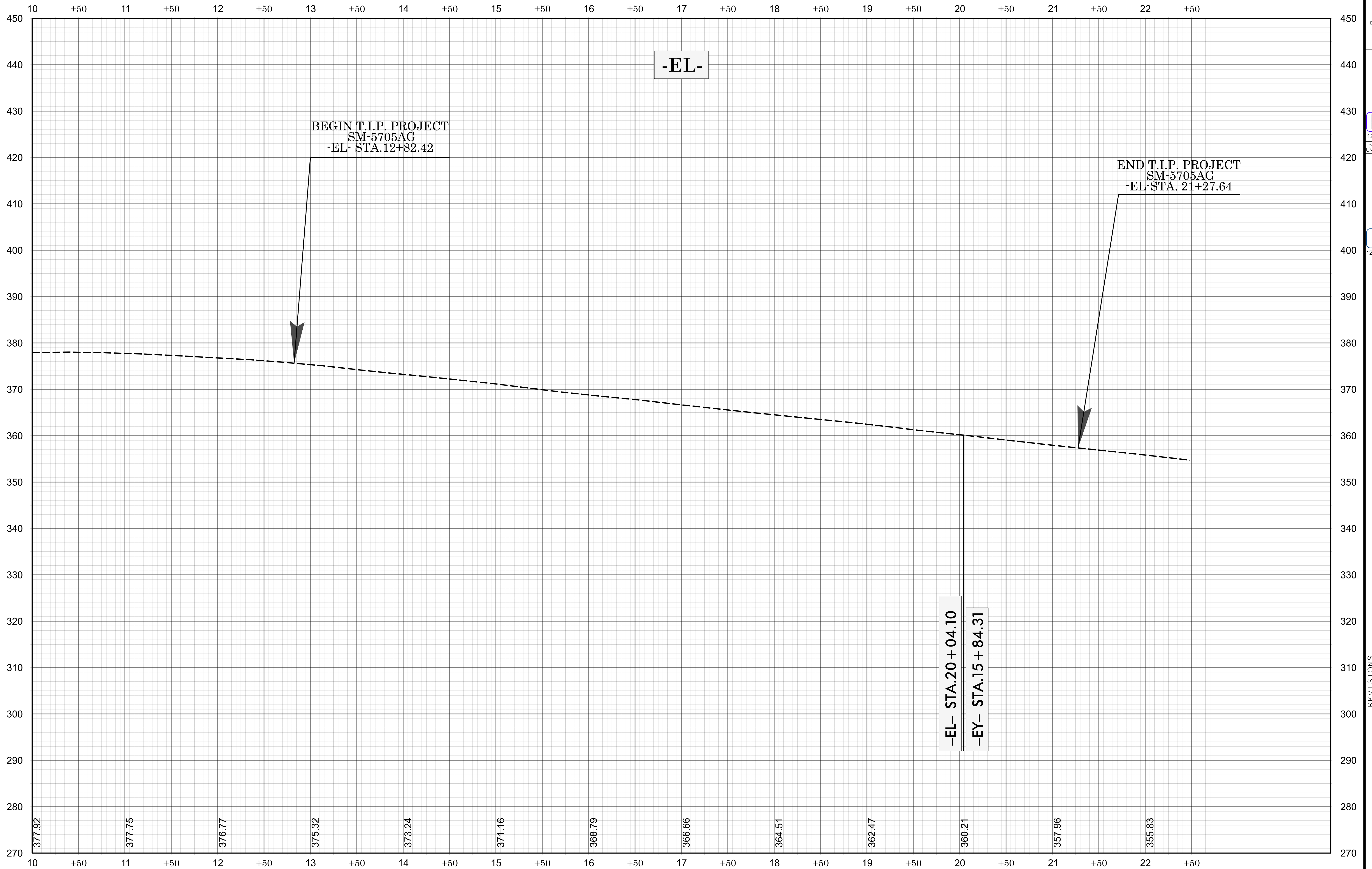

REVISIONS

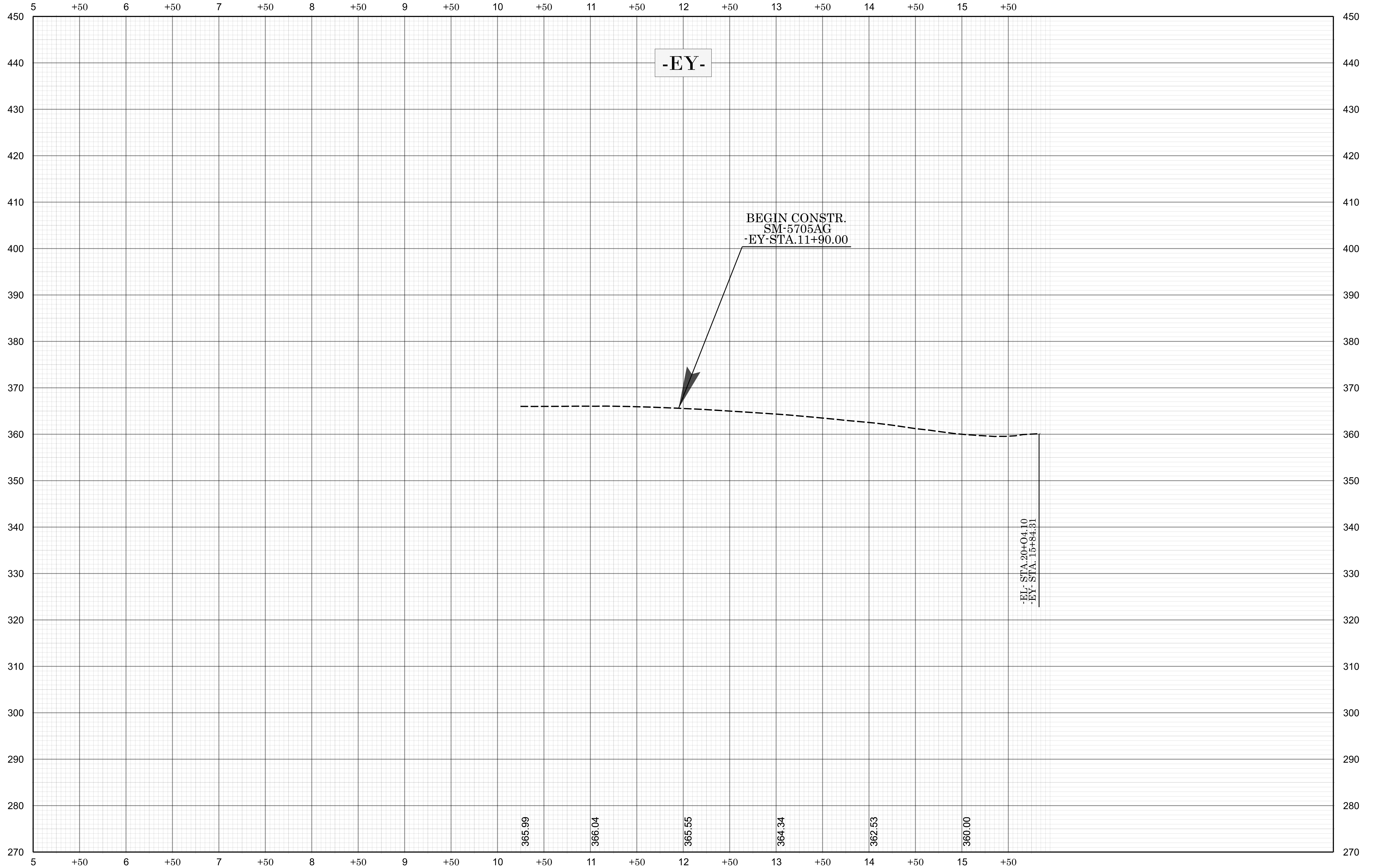
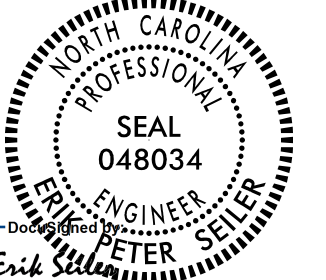
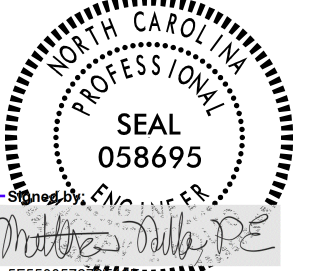

REVISIONS

INDEX OF SHEETS, LIST OF STANDARD DRAWINGS, & GENERAL NOTES

SM-B105H / HS-2405AH

4RDI IA

NORTH CAROLINA
DEPARTMENT OF TRANSPORTATION
DURHAM COUNTY

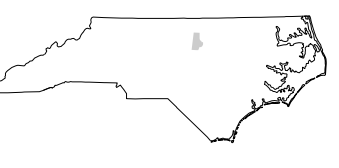

ROADWAY DESIGN UNIT
ROADWAY DESIGN
ENGINEER

2/16/2026

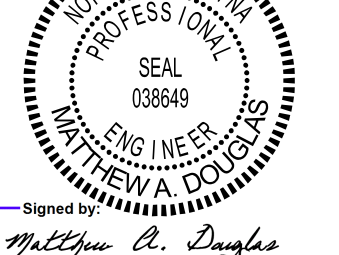

Signed by
Matthew A. Douglas
#038649-01234567

DOCUMENT NOT CONSIDERED FINAL
UNLESS ALL SIGNATURES COMPLETED

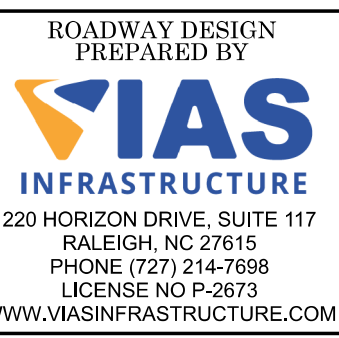

INDEX OF SHEETS

SHEET NUMBER	SHEET
1	TITLE SHEET
1A	INDEX OF SHEETS, GENERAL NOTES, AND STANDARD DRAWINGS
1B	CONVENTIONAL SYMBOLS
2A-1	PAVEMENT SCHEDULE AND TYPICAL SECTIONS
2B-1	CURB ALIGNMENT & PROFILE DETAIL
2B-2	SIDEPATH & MEDIAN ISLAND DETAILS
2C-1 THRU 2C-3	SPECIAL DETAILS
3B-1	ROADWAY SUMMARIES
3D-1	DRAINAGE SUMMARY SHEET
3G-1	GEOTECHNICAL SUMMARIES
4	PLAN SHEET
5	PROFILE SHEET
RW-01 THRU RW-04	RIGHT-OF-WAY SHEETS (SURVEY CONTROL SHEETS)
TMP-1 THRU TMP-6	TRANSPORTATION MANAGEMENT PLANS
PMP-1 & PMP-2	PAVEMENT MARKING PLANS
EC-1 THRU EC-5	EROSION CONTROL PLANS
SIGN-1 THRU SIGN-3	SIGNING PLANS
SIG-1.0 THRU SIG-4.5	SIGNAL PLANS
UO-1 & UO-2	UTILITIES BY OTHERS PLANS
X-0	CROSS-SECTION INDEX SHEET
X-1 THRU X-10	CROSS-SECTIONS

LIST OF STANDARD DRAWINGS

EFF. 01-16-2024
REV.

2024 ROADWAY ENGLISH STANDARD DRAWINGS

The following Roadway Standards as appear in "Roadway Standard Drawings" Contracts Standards and Development Unit - N. C. Department of Transportation - Raleigh, N. C., Dated January 16, 2024 are applicable to this project and by reference hereby are considered a part of these plans:

STD.NO.	TITLE
DIVISION 2 - EARTHWORK	
200.03	Method of Clearing - Method III
225.02	Guide for Grading Subgrade - Secondary and Local
225.04	Method of Obtaining Superelevation - Two Lane Pavement
225.06	Method of Grading Sight Distance at Intersections
DIVISION 8 - INCIDENTALS	
806.01	Concrete Right-of-Way Marker
806.02	Granite Right-of-Way Marker
840.00	Concrete Base Pad for Drainage Structures
840.01	Brick Catch Basin - 12" thru 54" Pipe
840.02	Concrete Catch Basin - 12" thru 54" Pipe
840.03	Frame, Grates and Hood - for Use on Standard Catch Basin
846.01	Concrete Curb, Gutter and Curb & Gutter
848.07	Concrete Sidepath / Shared Use Path / Greenway Construction
852.01	Concrete Islands

NOTE:

See special details in the plans for Method of Pipe Installation, Concrete Sidewalk, & Curb Ramps.

GENERAL NOTES

GENERAL NOTES: 2024 SPECIFICATIONS
EFFECTIVE: 01-16-2024
REVISED:

GRADING AND SURFACING OR RESURFACING AND WIDENING:

THE GRADE LINES SHOWN DENOTE THE FINISHED ELEVATION OF THE PROPOSED SURFACING AT GRADE POINTS SHOWN ON THE TYPICAL SECTIONS. WHERE NO GRADE LINES ARE SHOWN, THE PROFILES SHOWN DENOTE THE TOP ELEVATION OF THE EXISTING PAVEMENT ALONG THE CENTER LINE OF SURVEY ON WHICH THE PROPOSED RESURFACING WILL BE PLACED. GRADE LINES MAY BE ADJUSTED BY THE ENGINEER IN ORDER TO SECURE A PROPER TIE-IN.

CLEARING:

CLEARING ON THIS PROJECT SHALL BE PERFORMED TO THE LIMITS ESTABLISHED BY METHOD III.

SUPERELEVATION:

ALL CURVES ON THIS PROJECT SHALL BE SUPERELEVATED IN ACCORDANCE WITH STD. NO. 225.04 USING THE RATE OF SUPERELEVATION AND RUNOFF SHOWN ON THE PLANS. SUPERELEVATION IS TO BE REVOLVED ABOUT THE GRADE POINTS SHOWN ON THE TYPICAL SECTIONS.

SUBSURFACE PLANS:

NO SUBSURFACE PLANS ARE AVAILABLE ON THIS PROJECT. THE CONTRACTOR SHOULD MAKE HIS OWN INVESTIGATION AS TO THE SUBSURFACE CONDITIONS.

UTILITIES:

UTILITY OWNERS ON THIS PROJECT ARE: AT&T, CHARTER CITY OF DURHAM, CROWN CASTLE, DOMINION ENERGY, DUKE ENERGY, LUMEN, SEGRA GOOGLE FIBER, FRONTIER, AND VERIZON

ANY RELOCATION OF EXISTING UTILITIES WILL BE ACCOMPLISHED BY OTHERS.

RIGHT-OF-WAY MARKERS:

ALL RIGHT-OF-WAY MARKERS ON THIS PROJECT SHALL BE PLACED BY CONTRACT.

CURB RAMPS

CURB RAMPS ARE SHOWN ON THE PLANS AT APPROXIMATE LOCATIONS. CONSTRUCT ALL CURB RAMPS ACCORDANCE WITH SPECIAL DETAILS IN THE PLANS.

REVISIONS

Note: Not to Scale

STATE OF NORTH CAROLINA, DIVISION OF HIGHWAYS

CONVENTIONAL PLAN SHEET SYMBOLS

SM-B105H / HS-2405AH

4RDI 1B

BOUNDARIES AND PROPERTY:

State Line	-----
County Line	-----
Township Line	-----
City Line	-----
Reservation Line	-----
Property Line	-----
Existing Iron Pin (EIP)	○ EIP
Computed Property Corner	×
Existing Concrete Monument (ECM)	□ ECM
Parcel / Sequence Number	⑫③
Existing Fence Line	-x-x-x-
Proposed Woven Wire Fence	○
Proposed Chain Link Fence	□
Proposed Barbed Wire Fence	◇
Existing Wetland Boundary	-w-lb-
Proposed Wetland Boundary	-w-lb-
Existing Endangered Animal Boundary	-eab-
Existing Endangered Plant Boundary	-epb-
Existing Historic Property Boundary	-hpb-
Known Contamination Area: Soil	-s-s-
Potential Contamination Area: Soil	-s-s-
Known Contamination Area: Water	-w-w-
Potential Contamination Area: Water	-w-w-
Contaminated Site: Known or Potential	☠ ?

BUILDINGS AND OTHER CULTURE:

Gas Pump Vent or U/G Tank Cap	○
Sign	○ S
Well	○ W
Small Mine	×
Foundation	□
Area Outline	□
Cemetery	□ †
Building	□
School	□
Church	□
Dam	□

HYDROLOGY:

Stream or Body of Water	-----
Hydro, Pool or Reservoir	□
Jurisdictional Stream	-js-
Buffer Zone 1	-bz 1-
Buffer Zone 2	-bz 2-
Flow Arrow	←
Disappearing Stream	→
Spring	○
Wetland	⊥
Proposed Lateral, Tail, Head Ditch	← FLD
False Sump	◇

RAILROADS:

Standard Gauge	-----
RR Signal Milepost	○ MILEPOST 35
Switch	□ SWITCH
RR Abandoned	-----
RR Dismantled	-----

RIGHT OF WAY & PROJECT CONTROL:

Primary Horiz Control Point	○
Primary Horiz and Vert Control Point	●
Secondary Horiz and Vert Control Point	◆
Vertical Benchmark	⊗
Existing Right of Way Monument	△
Proposed Right of Way Monument (Rebar and Cap)	▲
Proposed Right of Way Monument (Concrete)	⊕
Existing Permanent Easement Monument	◇
Proposed Permanent Easement Monument (Rebar and Cap)	◇
Existing C/A Monument	△
Proposed C/A Monument (Rebar and Cap)	▲
Proposed C/A Monument (Concrete)	⊕
Existing Right of Way Line	-----
Proposed Right of Way Line	-----
Existing Control of Access Line	-----
Proposed Control of Access Line	-----
Proposed ROW and CA Line	-----
Existing Easement Line	-----
Proposed Temporary Construction Easement	-----
Permanent Construction Easement	-----
Proposed Temporary Drainage Easement	-----
Proposed Permanent Drainage Easement	-----
Proposed Permanent Drainage/Utility Easement	-----
Proposed Permanent Utility Easement	-----
Proposed Temporary Utility Easement	-----
Proposed Aerial Utility Easement	-----

ROADS AND RELATED FEATURES:

Existing Edge of Pavement	-----
Existing Curb	-----
Proposed Slope Stakes Cut	-c-
Proposed Slope Stakes Fill	-f-
Proposed Curb Ramp	○ CR
Existing Metal Guardrail	-----
Proposed Guardrail	-----
Existing Cable Guiderail	-----
Proposed Cable Guiderail	-----
Equality Symbol	⊕
Pavement Removal	⊗

VEGETATION:

Single Tree	⊗
Single Shrub	⊗

Hedge	-----
Woods Line	-----
Orchard	⊗
Vineyard	□ Vineyard

EXISTING STRUCTURES:

MAJOR:	
Bridge, Tunnel or Box Culvert	CONC
Bridge Wing Wall, Head Wall and End Wall	CONC WW
MINOR:	
Head and End Wall	CONC HW
Pipe Culvert	-----
Footbridge	-----
Drainage Box: Catch Basin, DI or JB	□ CB
Paved Ditch Gutter	-----
Storm Sewer Manhole	⊕
Storm Sewer	-----

UTILITIES: * SUE - Subsurface Utility Engineering
LOS - Level of Service - A,B,C or D (Accuracy)

POWER:	
Existing Power Pole	●
Proposed Power Pole	○
Existing Joint Use Pole	●
Proposed Joint Use Pole	○
Power Manhole	⊕
Power Line Tower	⊗
Power Transformer	⊗
U/G Power Cable Hand Hole	⊕
H-Frame Pole	●
U/G Power Line Test Hole (SUE - LOS A)*	●
U/G Power Line (SUE - LOS B)*	-----
U/G Power Line (SUE - LOS C)*	-----
U/G Power Line (SUE - LOS D)*	-----

TELEPHONE:	
Existing Telephone Pole	●
Proposed Telephone Pole	○
Telephone Manhole	⊕
Telephone Pedestal	⊕
Telephone Cell Tower	⊕
U/G Telephone Cable Hand Hole	⊕
U/G Telephone Test Hole (SUE - LOS A)*	●
U/G Telephone Cable (SUE - LOS B)*	-----
U/G Telephone Cable (SUE - LOS C)*	-----
U/G Telephone Cable (SUE - LOS D)*	-----
U/G Telephone Conduit (SUE - LOS B)*	-----
U/G Telephone Conduit (SUE - LOS C)*	-----
U/G Telephone Conduit (SUE - LOS D)*	-----
U/G Fiber Optics Cable (SUE - LOS B)*	-----
U/G Fiber Optics Cable (SUE - LOS C)*	-----
U/G Fiber Optics Cable (SUE - LOS D)*	-----

WATER:	
Water Manhole	⊕
Water Meter	○
Water Valve	⊗
Water Hydrant	⊕
U/G Water Line Test Hole (SUE - LOS A)*	●
U/G Water Line (SUE - LOS B)*	-----
U/G Water Line (SUE - LOS C)*	-----
U/G Water Line (SUE - LOS D)*	-----
Above Ground Water Line	-----

TV:	
TV Pedestal	⊕
TV Tower	⊗
U/G TV Cable Hand Hole	⊕
U/G TV Test Hole (SUE - LOS A)*	●
U/G TV Cable (SUE - LOS B)*	-----
U/G TV Cable (SUE - LOS C)*	-----
U/G TV Cable (SUE - LOS D)*	-----
U/G Fiber Optic Cable (SUE - LOS B)*	-----
U/G Fiber Optic Cable (SUE - LOS C)*	-----
U/G Fiber Optic Cable (SUE - LOS D)*	-----

GAS:	
Gas Valve	◇
Gas Meter	◇
U/G Gas Line Test Hole (SUE - LOS A)*	●
U/G Gas Line (SUE - LOS B)*	-----
U/G Gas Line (SUE - LOS C)*	-----
U/G Gas Line (SUE - LOS D)*	-----
Above Ground Gas Line	-----

SANITARY SEWER:	
Sanitary Sewer Manhole	⊕
Sanitary Sewer Cleanout	⊕
U/G Sanitary Sewer Line	-----
Above Ground Sanitary Sewer	-----
SS Force Main Line Test Hole (SUE - LOS A)*	●
SS Force Main Line (SUE - LOS B)*	-----
SS Force Main Line (SUE - LOS C)*	-----
SS Force Main Line (SUE - LOS D)*	-----

MISCELLANEOUS:	
Utility Pole	●
Utility Pole with Base	□
Utility Located Object	○
Utility Traffic Signal Box	⊕
Utility Unknown U/G Line (SUE - LOS B)*	-----
U/G Tank; Water, Gas, Oil	□
Underground Storage Tank, Approx. Loc.	⊕
A/G Tank; Water, Gas, Oil	□
Geoenvironmental Boring	⊕
Abandoned According to Utility Records	AATUR
End of Information	E.O.I.

PAVEMENT SCHEDULE

(PROVIDED BY DIVISION)

C1	PROP. APPROX. 1½" ASPHALT CONCRETE SURFACE COURSE, TYPE S9.5C, AT AN AVERAGE RATE OF 168 LBS. PER SQ. YD.	R1	PROPOSED 2'-6" CONCRETE CURB & GUTTER	T	EARTH MATERIAL
C2	PROP. APPROX. 3" ASPHALT CONCRETE SURFACE COURSE, TYPE S9.5C, AT AN AVERAGE RATE OF 168 LBS. PER SQ. YD. IN EACH OF TWO LAYERS	R2	PROPOSED 5" MONOLITHIC CONCRETE ISLAND (KEYED IN)	U	EXISTING PAVEMENT
D1	PROP. APPROX. 4" ASPHALT CONCRETE INTERMEDIATE COURSE, TYPE I19.0C, AT AN AVERAGE RATE OF 456 LBS. PER SQ. YD.	S	PROPOSED SIDEPATH CONSTRUCTED OF 4" CONCRETE WITH WELDED WIRE MESH	V	1½" MILLING OF EXISTING PAVEMENT
E1	PROP. APPROX. 4" ASPHALT CONCRETE BASE COURSE, TYPE B25.0C, AT AN AVERAGE RATE OF 456 LBS. PER SQ. YD.	NOTE: ALL PAVEMENT EDGE SLOPES ARE 1:1 UNLESS SHOWN OTHERWISE.			

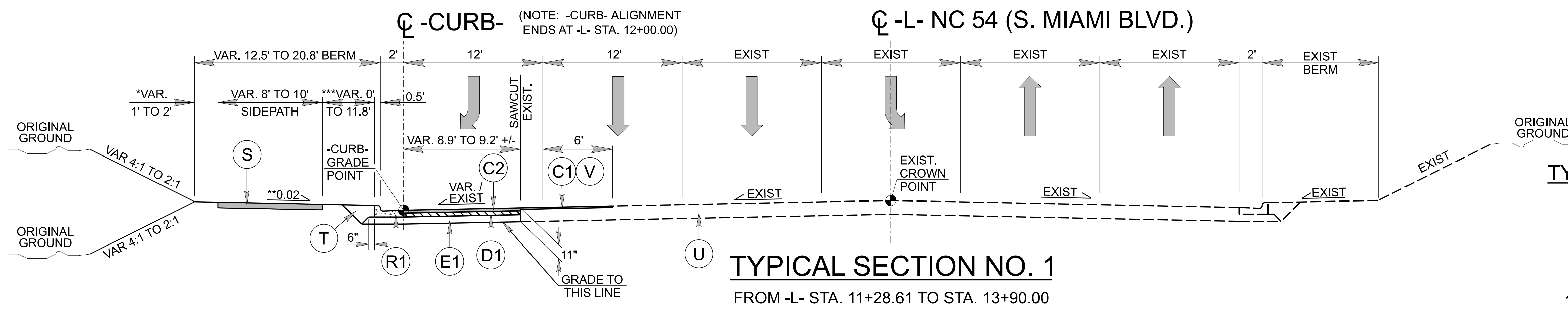

TYPICAL SECTION NO. 1
FROM -L- STA. 11+28.61 TO STA. 13+90.00

TYPICAL SECTION NO. 1 NOTES

- *NOTE: UTILIZE 1' BEYOND SIDEPATH IN CONSTRAINED AREAS NEAR UTILITY POLES AND FENCES.
- **NOTE: UTILIZE 0.01 BERM SLOPE FROM -L- STA. 11+64.06 TO STA. 12+15.00
- ***NOTE: IF DISTANCE BETWEEN SIDEPATH AND BACK OF CURB IS LESS THAN 2', EXTEND SIDEPATH TO BACK OF CURB.
- NOTE: SEE SHEET 2B-1 FOR LOCATION OF SAW CUT

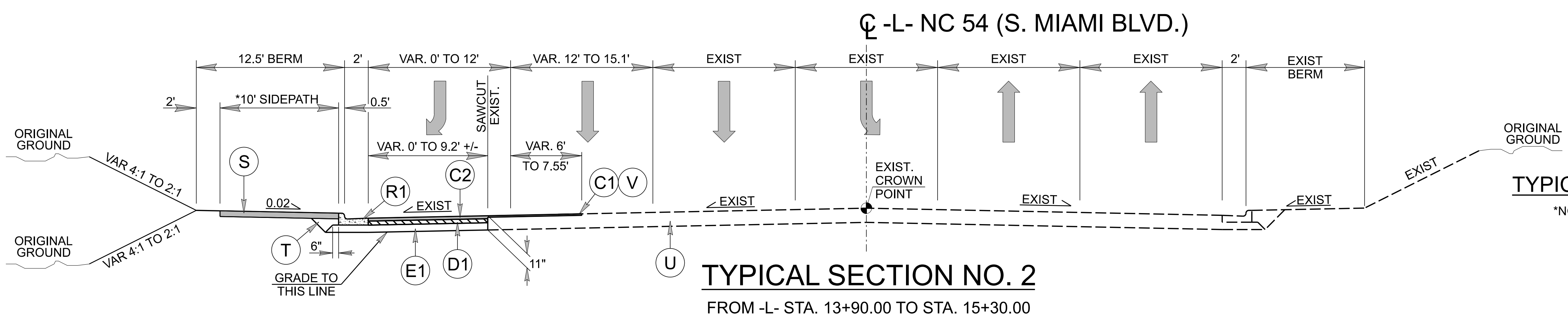

TYPICAL SECTION NO. 2
FROM -L- STA. 13+90.00 TO STA. 15+30.00

TYPICAL SECTION NO. 2 NOTES

- *NOTE: TRANSITION FROM 10' SIDEPATH TO EXISTING 5' SIDEWALK FROM -L- STA. 15+05.00 TO STA. 15+30.00

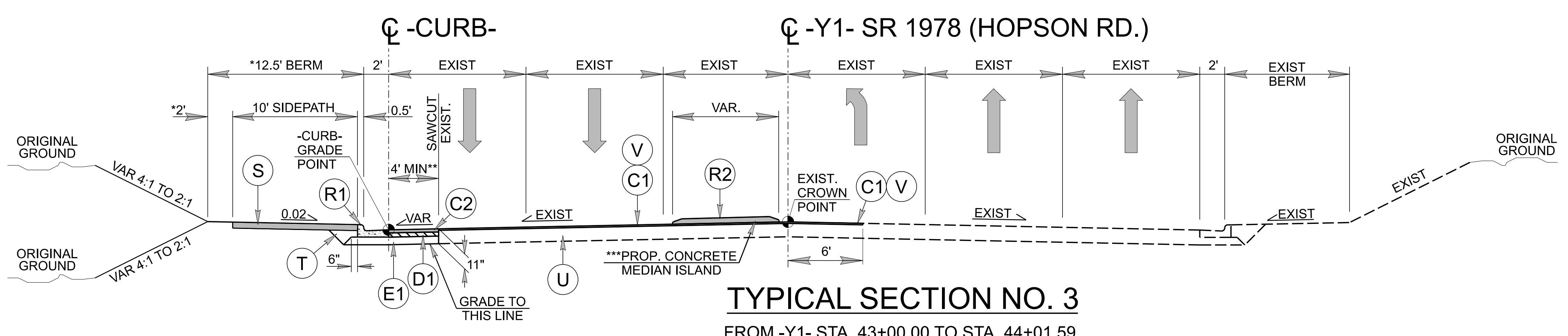

TYPICAL SECTION NO. 3
FROM -Y1- STA. 43+00.00 TO STA. 44+01.59

TYPICAL SECTION NO. 3 NOTES

- *NOTE: UTILIZE 1' SHOULDER AND 11.5' BERM WIDTH -Y1- STA. 43+00.00 TO STA. 43+40.00
- **NOTE: SEE SHEET 2B-1 FOR LOCATION OF SAW CUT
- ***SEE SHEET 2B-2 FOR LOCATION OF CONCRETE ISLAND (NOTE: MEDIAN ISLAND WORK ENDS AT STA. 43+70.00)

SM-B105H / HS-2405AH

4RD1 2A-1

NORTH CAROLINA DEPARTMENT OF TRANSPORTATION DURHAM COUNTY

ROADWAY DESIGN UNIT

ROADWAY DESIGN ENGINEER

2/16/2026

Professional Engineer Seal: Matthew A. Douglas, License No. 038849

DOCUMENT NOT CONSIDERED FINAL UNLESS ALL SIGNATURES COMPLETED

PAVEMENT DESIGN ENGINEER

2/19/2026

Professional Engineer Seal: Matthew A. Douglas, License No. 058695

ROADWAY DESIGN PREPARED BY

VIAS INFRASTRUCTURE

220 HORIZON DRIVE, SUITE 117 RALEIGH, NC 27615 PHONE (727) 214-7698 LICENSE NO. P-2673 WWW.VIASINFRASTRUCTURE.COM

REVISIONS

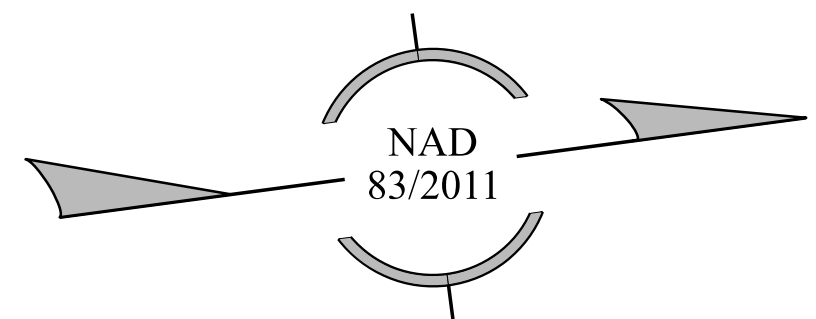
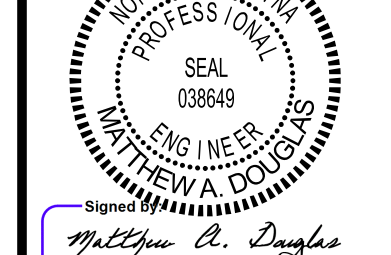
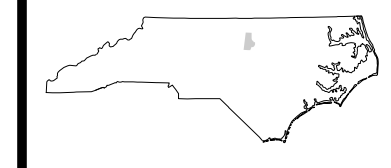

CURVE DATA		
CUR DATA -CURB- Plc 10+24.40 $\Delta c = 00^{\circ}23'08.1"$ (RT) D = $00^{\circ}47'23.9"$ Lc = 48.81 Tc = 24.40 R = 7,252.85	CUR DATA -CURB- Plc 10+52.94 $\Delta c = 18^{\circ}45'21.3"$ (LT) D = $229^{\circ}10'59.2"$ Lc = 8.18 Tc = 4.13 R = 25	CUR DATA -CURB- Plc 10+91.30 $\Delta c = 63^{\circ}54'36.4"$ (LT) D = $104^{\circ}10'26.9"$ Lc = 61.35 Tc = 34.31 R = 55

NOTE: -CURB- ALIGNMENT IS AT PROPOSED EOT.

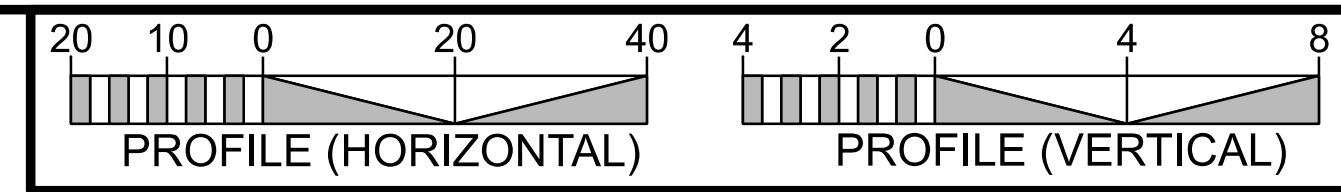
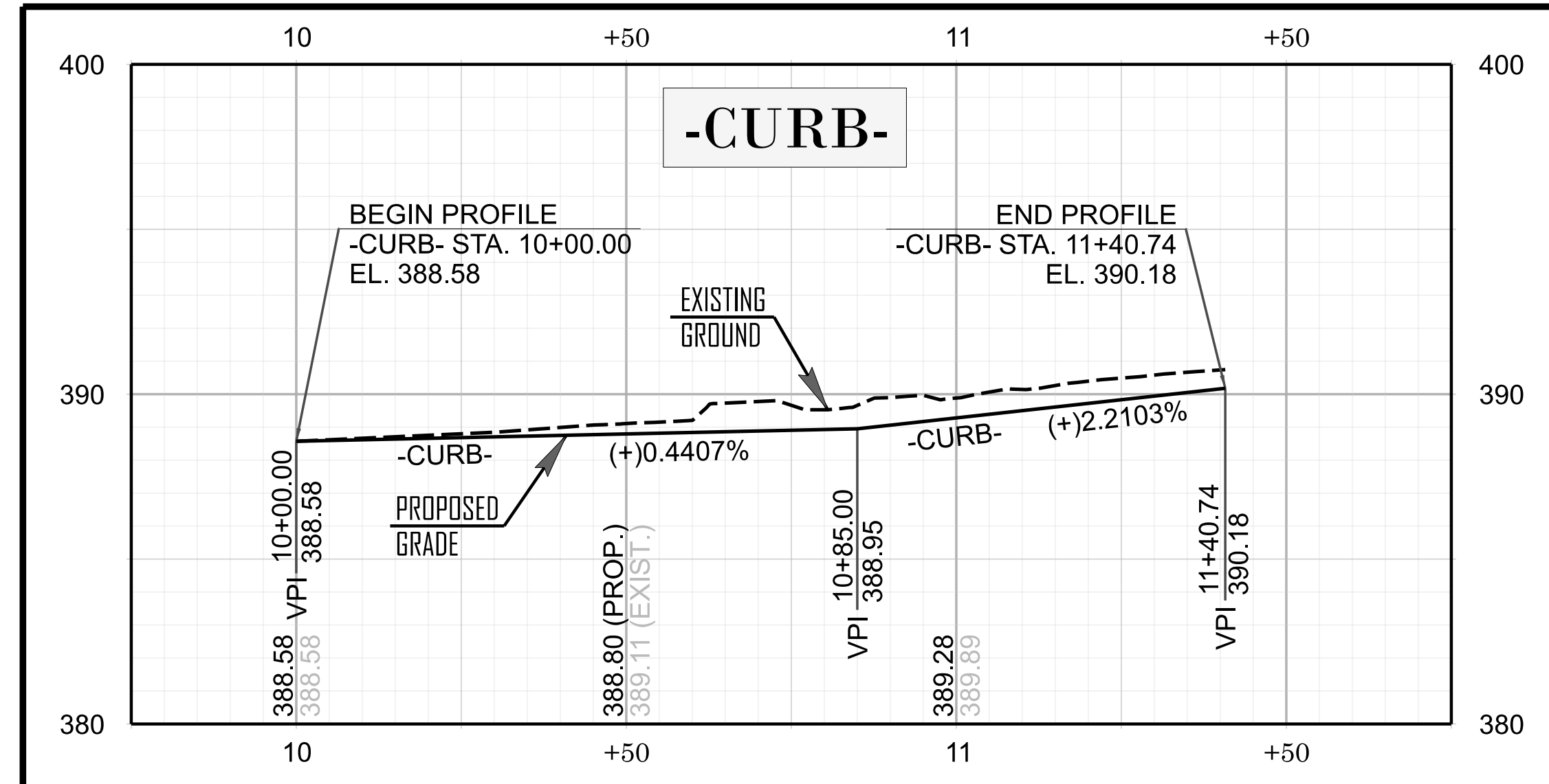
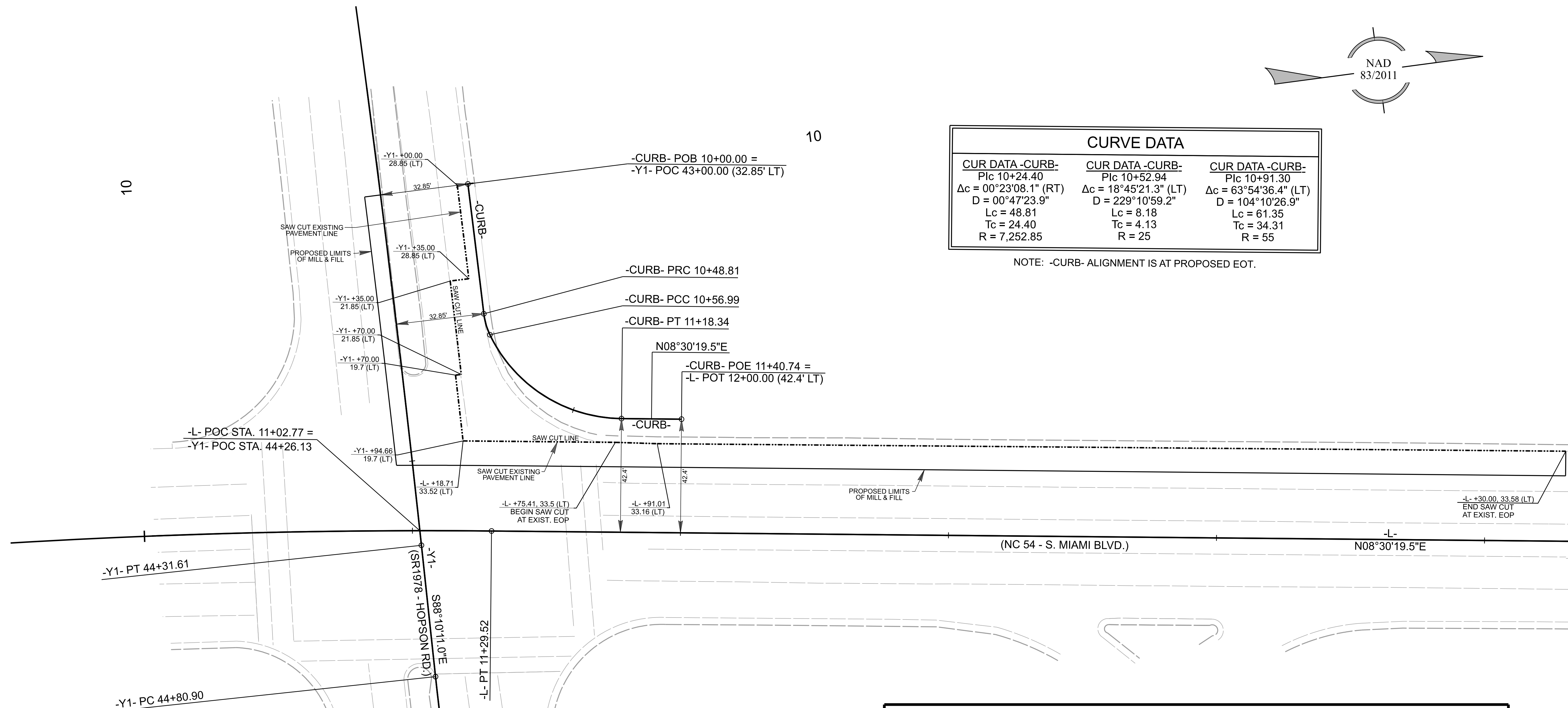

FOR DESIGNS SEE SHEET 4.

CURB ALIGNMENT & PROFILE DETAIL SAW CUT EXISTING PAVEMENT DETAIL

REVISIONS

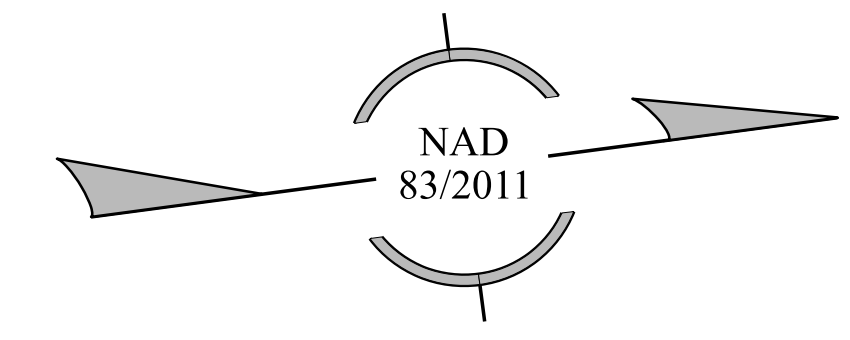

SM-6105H / HS-2405AH

4RD1 2B-2

NORTH CAROLINA
DEPARTMENT OF TRANSPORTATION
DURHAM COUNTY

ROADWAY DESIGN UNIT

ROADWAY DESIGN ENGINEER

12/19/2025

NORTH CAROLINA
PROFESSIONAL
SEAL
038649
MATTHEW A. DOUGLAS

Signature: Matthew A. Douglas

DOCUMENT NOT CONSIDERED FINAL
UNLESS ALL SIGNATURES COMPLETED.

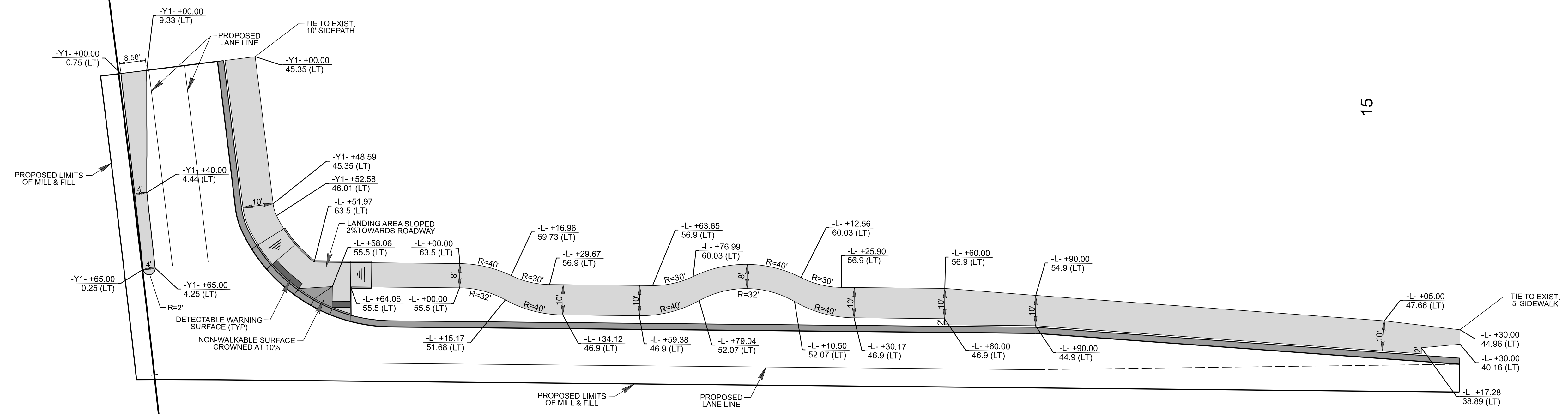

N08°30'19.5\"E
(NC 54 - S. MIAMI BLVD.)

-Y1- S88°10'11.0\"E
(SR1978 - HOPSON RD.)

ROADWAY DESIGN
PREPARED BY

VIAS
INFRASTRUCTURE

220 HORIZON DRIVE, SUITE 117
RALEIGH, NC 27615
PHONE (727) 214-7698
LICENSE NO P-2673
WWW.VIASINFRASTRUCTURE.COM

REVISIONS

MEDIAN CONCRETE ISLAND & SIDEWALK DETAIL SHEET

FOR DESIGNS SEE SHEET 4.

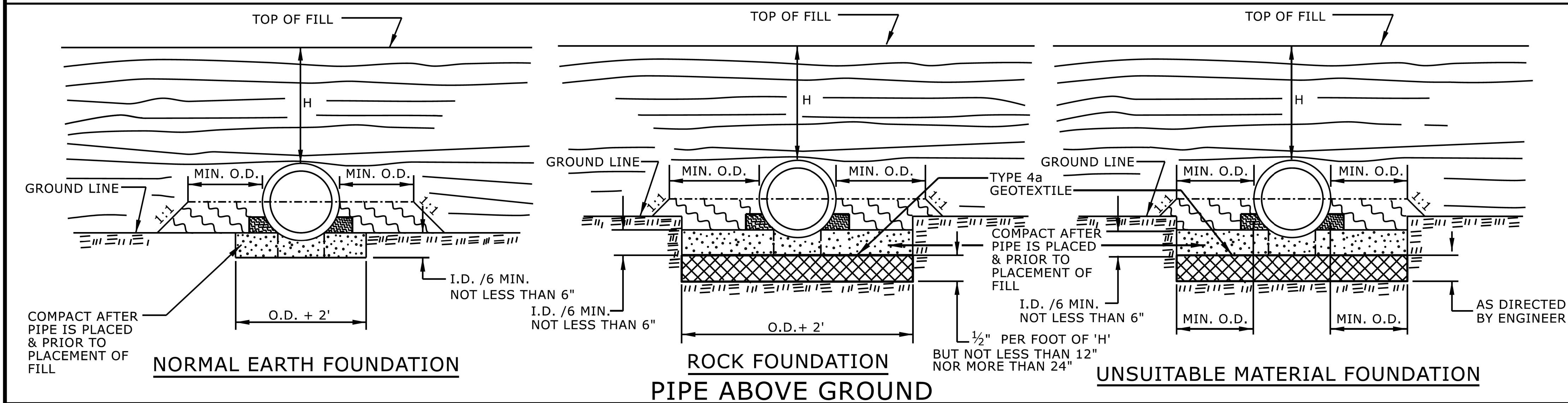
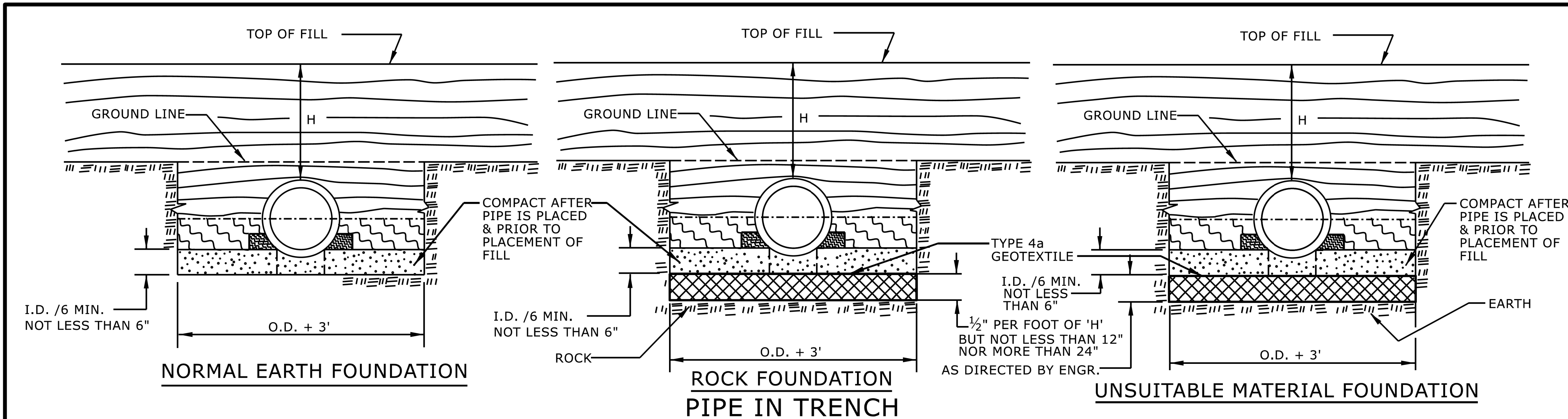



STATE OF
NORTH CAROLINA
DEPT. OF TRANSPORTATION
DIVISION OF HIGHWAYS
RALEIGH, N.C.

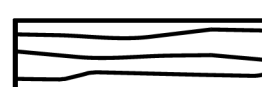

ROADWAY DETAIL DRAWING FOR
METHOD OF PIPE INSTALLATION
RIGID PIPE

SHEET 2 OF 2
300.01

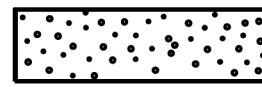
GENERAL NOTES:
 I.D. = THE MAXIMUM HORIZONTAL INSIDE DIAMETER DIMENSION.
 O.D. = THE MAXIMUM HORIZONTAL OUTSIDE DIAMETER DIMENSION.
 H = THE FILL HEIGHT MEASURED VERTICALLY AT ANY POINT ALONG THE PIPE FROM THE TOP OF THE PIPE TO THE TOP OF THE EMBANKMENT AT THAT POINT.

 APPROVED SUITABLE LOCAL MATERIAL.
 TAKE CARE TO FULLY COMPACT HAUNCH ZONE OF PIPE BACKFILL.
 LOOSELY PLACED SELECT MATERIAL CLASS III OR CLASS II, TYPE 1 FOR PIPE BEDDING. LEAVE SECTION DIRECTLY BENEATH PIPE UNCOMPACTED AS PIPE SEATING AND BACKFILL WILL ACCOMPLISH COMPACTION.

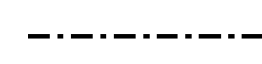
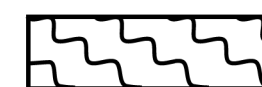
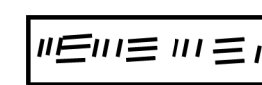
DO NOT OPERATE HEAVY EQUIPMENT OVER ANY PIPE CULVERT UNTIL THE PIPE CULVERT HAS BEEN PROPERLY BACKFILLED AND COVERED WITH AT LEAST 3 FEET OF APPROVED MATERIAL.
 REFER TO NCDOT PIPE MATERIAL SELECTION GUIDE AND STANDARD SPECIFICATIONS FOR ALLOWABLE PIPE FILL HEIGHTS AND PIPE SPECIFICATIONS.

 SPRINGLINE OF PIPE
 SELECT BACKFILL MATERIAL CLASS III OR CLASS II, BELOW SPRINGLINE.
 UNDISTURBED EARTH MATERIAL
 SELECT MATERIAL CLASS V OR VI FOR FOUNDATION CONDITIONING. ENCAPSULATE WITH TYPE IV GEOTEXTILE AS DIRECTED BY THE ENGINEER.



REVISIONS

DOCUMENT NOT CONSIDERED FINAL
 UNLESS ALL SIGNATURES COMPLETED

**CONTRACTS STANDARDS
 AND DEVELOPMENT UNIT**
 Office 919-707-6950 FAX 919-250-4119

SEE TITLE BLOCK

ORIGINAL BY: S.CALHOUN DATE: 7-25-2024
 MODIFIED BY: DATE: _____
 CHECKED BY: DATE: _____
 FILE SPEC: _____

NOTES:

CONSTRUCT STANDARD SIDEWALK 5' WIDE AND 4" THICK UNLESS OTHERWISE DENOTED ON PLANS.

PLACE A GROOVE JOINT 1" DEEP WITH 1/8" RADII IN THE CONCRETE SIDEWALK AT 5' INTERVALS. ONE 1/2" EXPANSION JOINT WILL BE REQUIRED AT 50' INTERVALS. A 1/2" EXPANSION JOINT WILL BE REQUIRED WHERE THE SIDEWALK JOINS ANY RIGID STRUCTURE.

SEE STD. DWG. 848.06 FOR CURB RAMP LOCATION REQUIREMENTS AND CONSTRUCTION GUIDELINES.

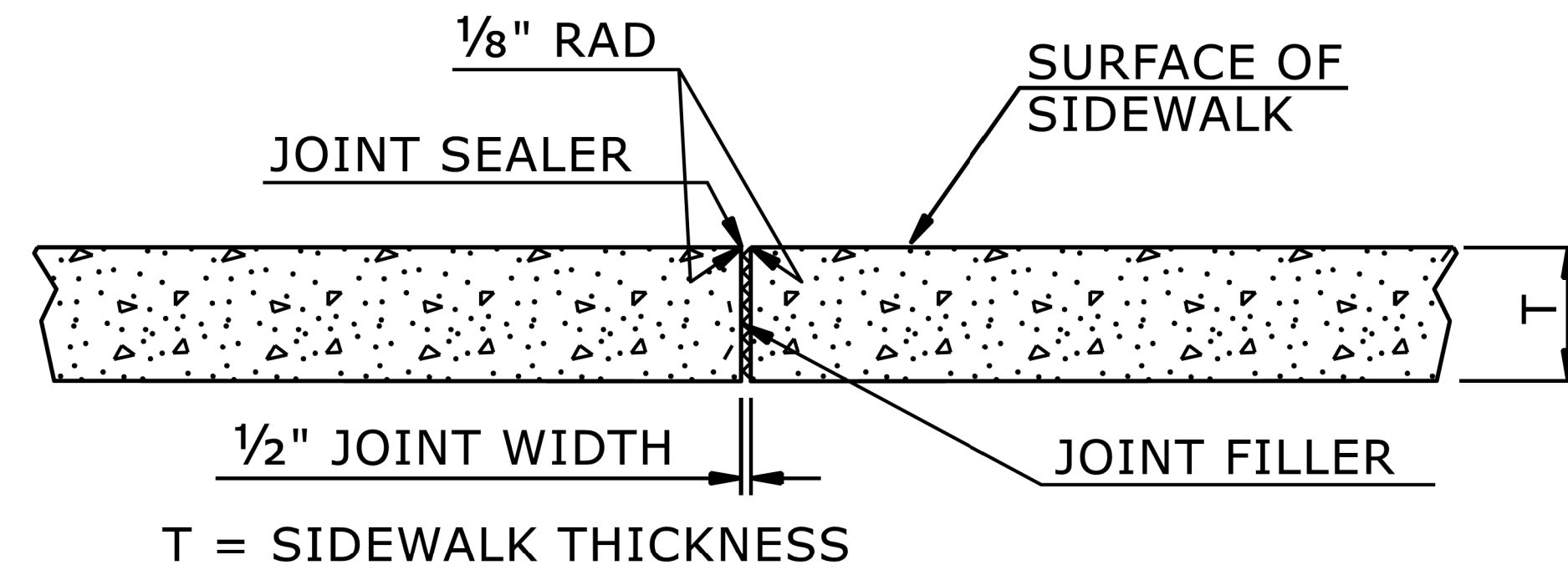

TRANSVERSE EXPANSION JOINT IN SIDEWALK

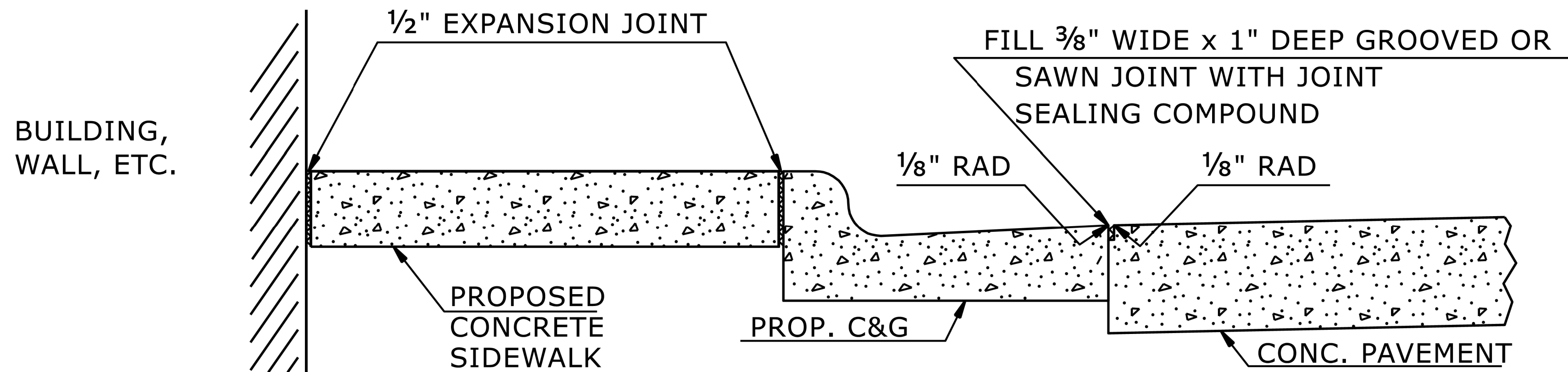

DETAILS SHOWING JOINTS IN CONCRETE SIDEWALK

STATE OF NORTH CAROLINA
DEPT. OF TRANSPORTATION
DIVISION OF HIGHWAYS
RALEIGH, N.C.

ROADWAY DETAIL DRAWING FOR
CONCRETE SIDEWALK

SHEET 1 OF 1
848D01

SM-6105H / HS-2405AH

4R01 | 2C-2

NORTH CAROLINA
DEPARTMENT OF TRANSPORTATION
DURHAM COUNTY

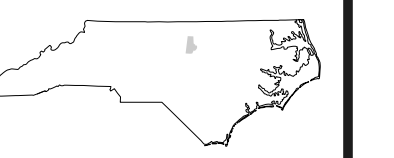

ROADWAY DESIGN UNIT

DOCUMENT NOT CONSIDERED FINAL
UNLESS ALL SIGNATURES COMPLETED



Signed by:
Nicole M. Hackler
588432034164CS

REVISIONS

DOCUMENT NOT CONSIDERED FINAL
UNLESS ALL SIGNATURES COMPLETED

CONTRACTS STANDARDS
AND DEVELOPMENT UNIT
Office 919-707-6950 FAX 919-250-4119

SEE TITLE BLOCK

ORIGINAL BY: S.CALHOUN DATE: 7-25-2024
MODIFIED BY: DATE:
CHECKED BY: DATE:
FILE SPEC: DATE:

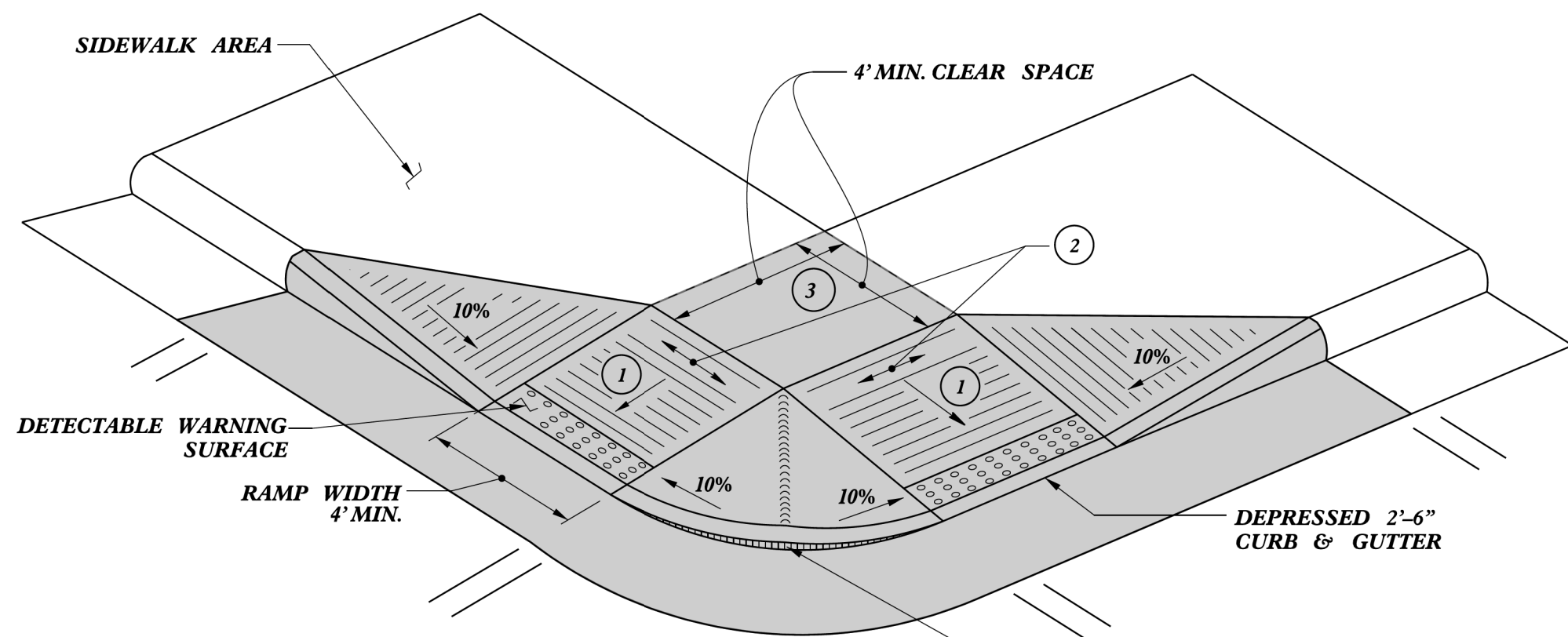

TYPE 4

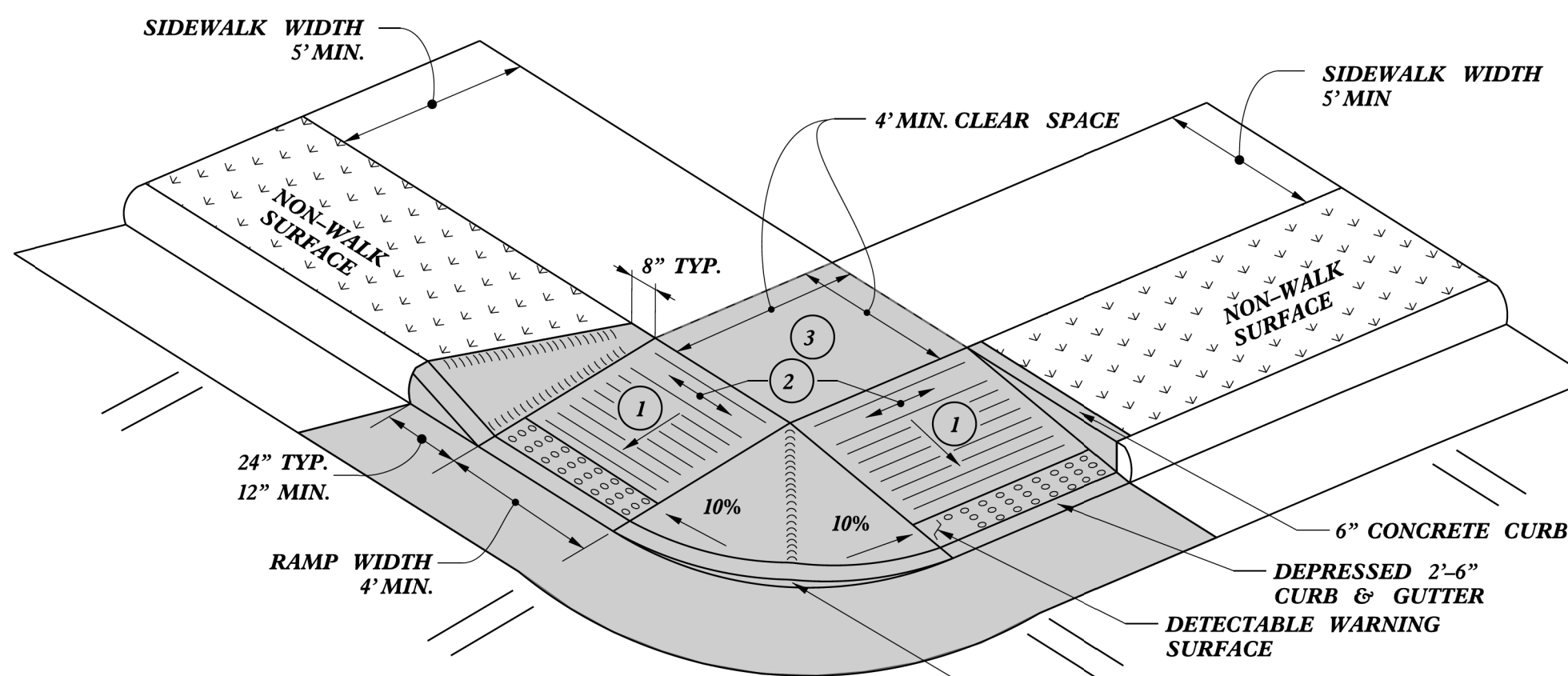

TYPE 4A

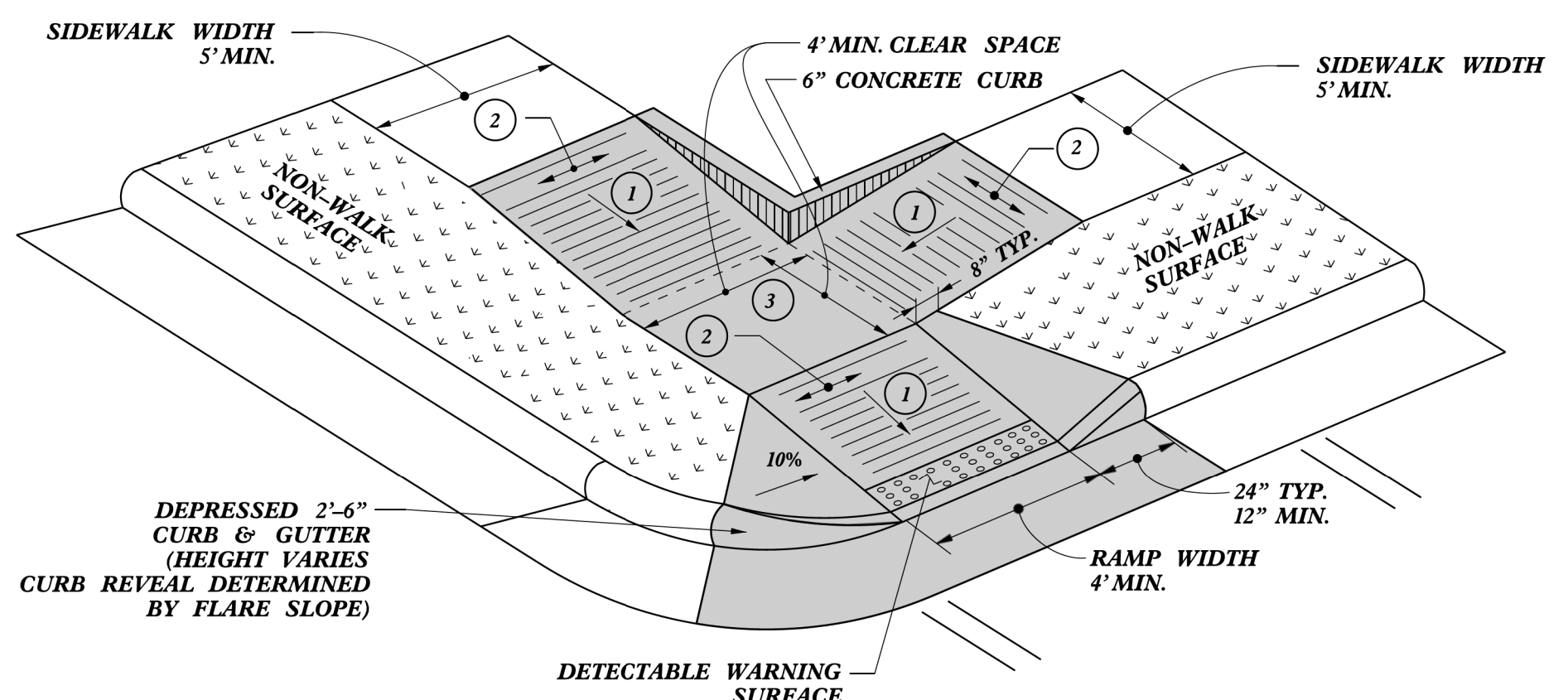

TYPE 4B

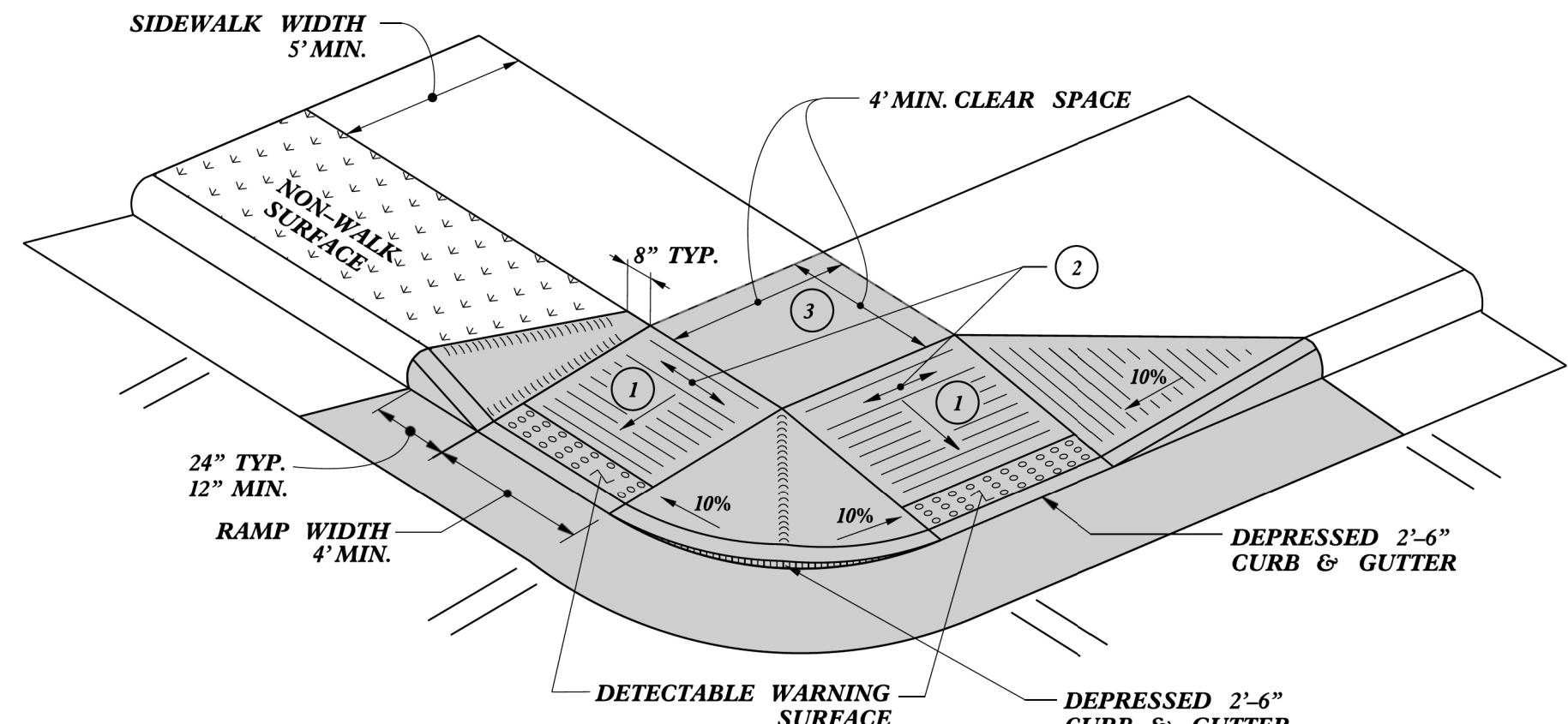

TYPE 4C

NOTES:
 DETECTABLE WARNING SURFACE SHALL COVER 2'-0" LENGTH AND FULL WIDTH OF THE RAMP FLOOR AS SHOWN ON THE DETAILS.
 DETECTABLE WARNING SURFACE SHALL CONTRAST VISIBLY WITH ADJOINING SURFACE, EITHER LIGHT-ON-DARK, OR DARK-ON-LIGHT SEQUENCE COVERING THE ENTIRE RAMP.

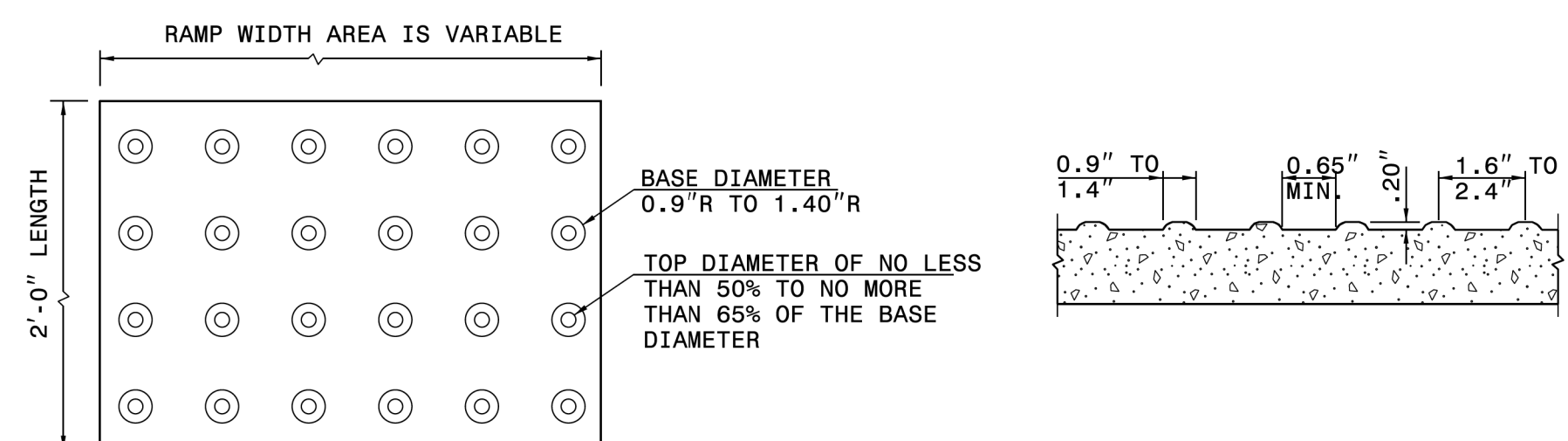

DETECTABLE WARNING SURFACE

- 1 8.33% (12:1) MAX RAMP SLOPE
- 2 CROSS SLOPE: 2.00%
- 3 MAXIMUM CROSS SLOPE AND LONGITUDINAL SLOPE OF 2.00%.

PAY LIMITS FOR 1 OR 2 CURB RAMPS (CALCULATE BASED ON NUMBER OF SETS OF DETECTABLE WARNING SURFACES)

STATE OF NORTH CAROLINA
 DEPT. OF TRANSPORTATION
 DIVISION OF HIGHWAYS
 RALEIGH, N.C.

ROADWAY DETAIL DRAWING FOR
CURB RAMP
 SHARED LANDING

SHEET 10 OF 13
848D06

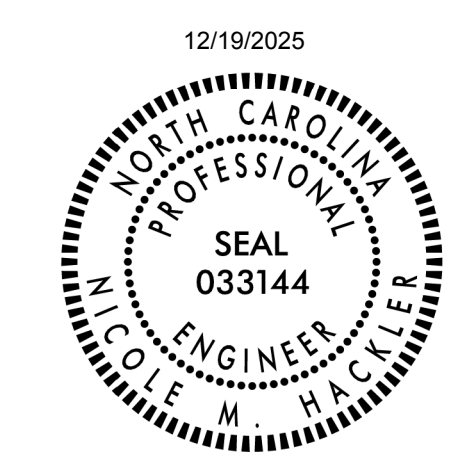

Signed by:
Nicole M. Hecker
 5884323034164C5...

REVISIONS

**DOCUMENT NOT CONSIDERED FINAL
 UNLESS ALL SIGNATURES COMPLETED**

**CONTRACTS STANDARDS
 AND DEVELOPMENT UNIT**
 Office 919-707-6950 FAX 919-250-4119

SEE TITLE BLOCK

ORIGINAL BY: S.CALHOUN DATE: 12-22-2023
 MODIFIED BY: DATE:
 CHECKED BY: DATE:
 FILE SPEC.: special_details\nmhackler\848D0610.dgn

COMPUTED BY: M. DOUGLAS DATE: 10/28/2024
 CHECKED BY: J. ADORNO DATE: 10/28/2024

STATE OF NORTH CAROLINA - DIVISION OF HIGHWAYS

EARTHWORK SUMMARY

STATION	STATION	EXCAVATION		EMBANKMENT	BORROW	TOTAL WASTE
		TOTAL UNCLASS.	UNDERCUT			
-L- 11+28.26	-L- 15+30.00	285		5		280
-Y1- 43+00.00	-Y1- 43+97.00	124		8		116
SUBTOTAL		409		13		396
TOTAL		409		13		396
LOSS DUE TO CLEARING & GRUBBING WASTE IN LIEU OF BORROW						
PROJECT TOTAL		409		13		396
EST. 5% TO REPLACE TOP SOIL ON BORROW PIT						
GRAND TOTAL						
SAY		425				400

UNDERCUT (CONTINGENCY) = 100 CY
 SELECT GRANULAR MATERIAL (CONTINGENCY) = 100 CY
 GEOTEXTILE FOR SOIL STABILIZATION (CONTINGENCY) = 100 SY
 SHALLOW UNDERCUT (CONTINGENCY) = 100 CY
 CLASS IV SUBGRADE STABILIZATION (CONTINGENCY) = 200 TON
 GEOTEXTILE FOR SUBGRADE STABILIZATION (CONTINGENCY) = 300 SY

Note: Approximate quantities only. Unclassified excavation, borrow excavation, fine grading, clearing and grubbing, and removal of existing pavement will be paid for at the contract lump sum price for grading.

Note: Earthwork quantities are calculated by the roadway designer. No subsurface data is available for this project.

SM-6105H / HS-2405AH

4R01 3B-1

NORTH CAROLINA
 DEPARTMENT OF TRANSPORTATION
 DURHAM COUNTY

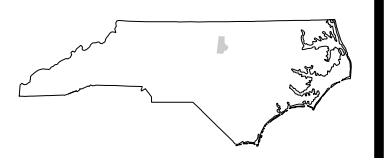

ROADWAY DESIGN UNIT

DOCUMENT NOT CONSIDERED FINAL
 UNLESS ALL SIGNATURES COMPLETED

ROADWAY DESIGN
 PREPARED BY
VIAS
 INFRASTRUCTURE
 220 HORIZON DRIVE, SUITE 117
 RALEIGH, NC 27615
 PHONE (777) 214-7698
 LICENSE NO P-2673
 WWW.VIASINFRASTRUCTURE.COM

REVISIONS

PAVEMENT REMOVAL - EXISTING ASPHALT

LINE	STATION	STATION	LOC	LENGTH OR AREA	WIDTH	SQUARE YARDS
-Y1-	43+00	43+98	LT	1,195.58		132.84
-L-	11+30	11+91	LT	61.28		6.81
					TOTAL	139.65
					SAY	140

PROPOSED 1.5" MILLING OF ASPHALT PAVEMENT

LINE	STATION	STATION	LOCATION	LENGTH	AREA	SQUARE FEET
-L-	11+30	15+30	LT		3,449.90	3,449.90
-Y-	43+00	43+98	CL		3,283.59	3,283.59
					TOTAL IN FT ²	6,733.49
					TOTAL IN YD ²	748.17
					SAY	750

STATE OF NORTH CAROLINA - DIVISION OF HIGHWAYS
NORTH CAROLINA DEPARTMENT OF TRANSPORTATION
DIVISION OF HIGHWAYS

COMPUTED BY: M. HARVEY DATE: 07 / 17 / 2024
CHECKED BY: K. ALFORD DATE: 07 / 19 / 2024

SM-6105H / HS-2405AH

4R01 | 3D-1

NORTH CAROLINA
DEPARTMENT OF TRANSPORTATION
DURHAM COUNTY

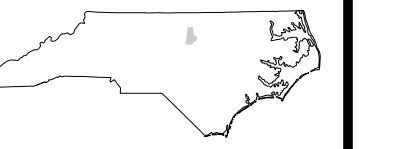

ROADWAY DESIGN UNIT

Note: Invert Elevations indicated are for Bid Purposes only and shall not be used for project construction stakeout.
See "Standard Specifications For Roads and Structures, Section 300-5".

LIST OF PIPES, ENDWALLS, ETC. (FOR PIPES 48 INCHES & UNDER)

Main data table with columns for Line & Station, Offset, Structure Number, Pipe Material, Pipe Class, Pipe Size, and various material specifications. Includes rows for stations L 13+87, L 12+84, L 11+78, Y1 43+60, and Y1 43+47.

SHEET TOTALS (48" or Less) and PROJECT TOTALS (48" or Less) summary table.

DOCUMENT NOT CONSIDERED FINAL
UNLESS ALL SIGNATURES COMPLETED

HYDRAULIC DESIGN
PREPARED BY



1223 Jones Franklin Rd.
Raleigh, N.C. 27606
License No. F-0377
Bus: 919 851 8077
Fax: 919 851 8107

REVISIONS

STATE OF NORTH CAROLINA, DIVISION OF HIGHWAYS GEOTECHNICAL QUANTITY SUMMARY SHEET

SM-6105H / HS-2405AH

4R01 | 3G-1

NORTH CAROLINA
DEPARTMENT OF TRANSPORTATION
DURHAM COUNTY

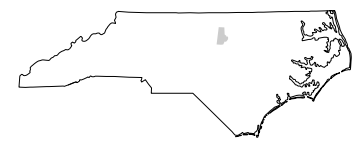

ROADWAY DESIGN UNIT

DOCUMENT NOT CONSIDERED FINAL
UNLESS ALL SIGNATURES COMPLETED

SUMMARY OF AGGREGATE SUBGRADE / STABILIZATION

LINE	Station	Station	Aggregate Type* ASU(1/2)/AST	Aggregate Thickness INCHES [8" for ASU(2)]	Shallow Undercut CY	Class IV Subgrade Stabilization TONS	Geotextile for Subgrade Stabilization SY	Stabilizer Aggregate TONS	Class IV Aggregate Stabilization TONS	
			CONTINGENCY	ASU(1)	12"	100	200	300		
			TOTAL CY/TONS/SY:			100	200**	300**	0	0

*ASU(1/2) = Aggregate Subgrade (Type 1 or 2)
 *AST = Aggregate Stabilization
 **Total tons of "Class IV Subgrade Stabilization" and total square yards of "Geotextile for Subgrade Stabilization" are only the estimated quantities for ASU(1/2)/AST and may only represent a portion of the subgrade stabilization and geotextile quantities shown in the Item Sheets of the Proposal.

CALC. BY: NEIL T. ROBERSON DATE: 08/28/2024
 CHECKED BY: JINYOUNG PARK DATE: 09/04/2024

REVISIONS

SPIRIT MASTER FUNDING VII, LLC
DB 7424 PG 656
PB 181 PG 287

SVASTI HOLDINGS, LLC
DB 8121 PG 559
PB 189 PG 256
PB 91 PG 77

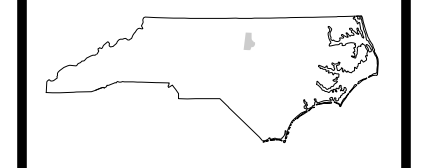

BEGIN CONSTRUCTION
-Y1- POC STA. 43+00.00

END RESURFACING
-Y1- POC STA. 44+01.59

BEGIN TIP PROJECT SM-6105H / HS-2405AH
-L- POC STA. 10+94.15

BEGIN CONSTRUCTION
-L- POC STA. 10+45.00

END TIP PROJECT SM-6105H / HS-2405AH
-L- POT STA. 15+30.00

END CONSTRUCTION
-Y1- POC STA. 46+25.00

NOTE: CONTRACTOR NOT TO DISTURB EXISTING FENCE AND BRICK COLUMNS ADJACENT TO WORK AREA.
NO CONSTRUCTION ACTIVITIES TO TAKE PLACE WITHIN EXISTING FENCED OFF AREA.

★ SIGNAL UPGRADE

CURVE DATA		
CUR DATA -L- Plc 9+89.89 Δc = 06°09'34.7" (RT) D = 02°12'13.3" Lc = 279.52 Tc = 139.89 R = 2,600 SE = EXIST. RO = EXIST.	CUR DATA -Y1- Plc 42+65.83 Δc = 02°37'53.6" (RT) D = 00°47'36.9" Lc = 331.61 Tc = 165.83 R = 7,220 SE = EXIST. RO = EXIST.	CUR DATA -Y1- Plc 47+25.73 Δc = 28°03'13.1" (LT) D = 05°50'47.4" Lc = 479.84 Tc = 244.83 R = 980 SE = EXIST. RO = EXIST.

CR1 NOTES:
 1) CR1 to be Type 4 per special details in the plans.
 2) Approximate ramp length on northern end of ramp is 6.9'.
 3) Approximate ramp length on southern end of ramp is 6.4'.
 4) Contractor to ensure all ramp slopes meet NCDOT Std. Dwg.

FOR CURB ALIGNMENT & PROFILE DETAILS, SEE SHEET 2B-1.
 FOR SAW CUTTING OF EXISTING PAVEMENT DETAIL, SEE SHEET 2B-1.
 FOR CONCRETE MEDIAN ISLAND & SIDEPAATH DETAILS, SEE SHEET 2B-2.

FOR -L- EXISTING GROUND PROFILE SEE SHEET 5.
 FOR -Y1- EXISTING GROUND PROFILE SEE SHEET 5.

SEE PAVEMENT MARKING PLANS FOR
 PLACEMENT OF ALL PAVEMENT MARKINGS.

CONTRACTOR TO TAKE GREAT CARE AND PRECAUTIONS WHEN
 GRADING AROUND EXISTING UTILITY POLES AND GUY WIRES.

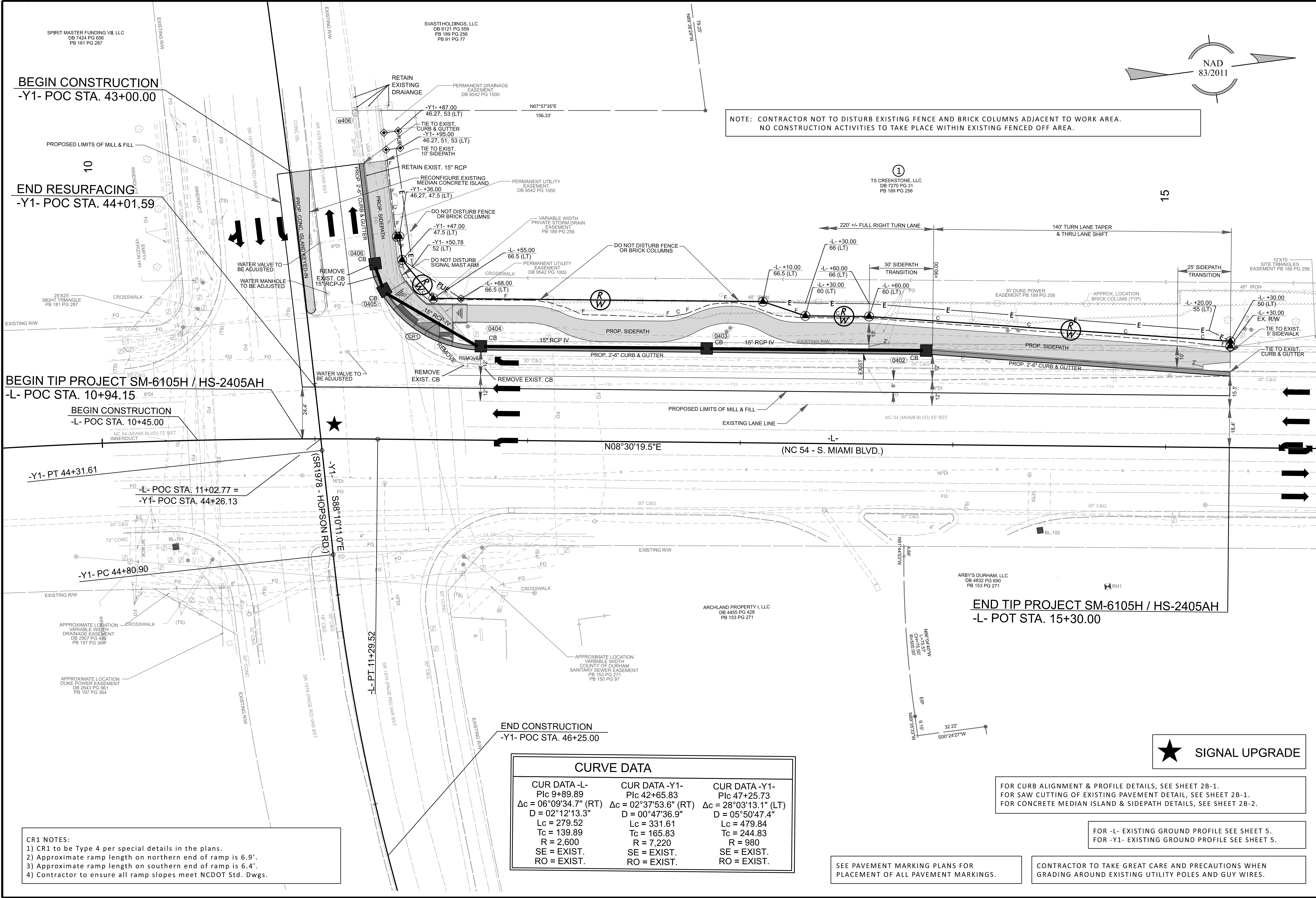

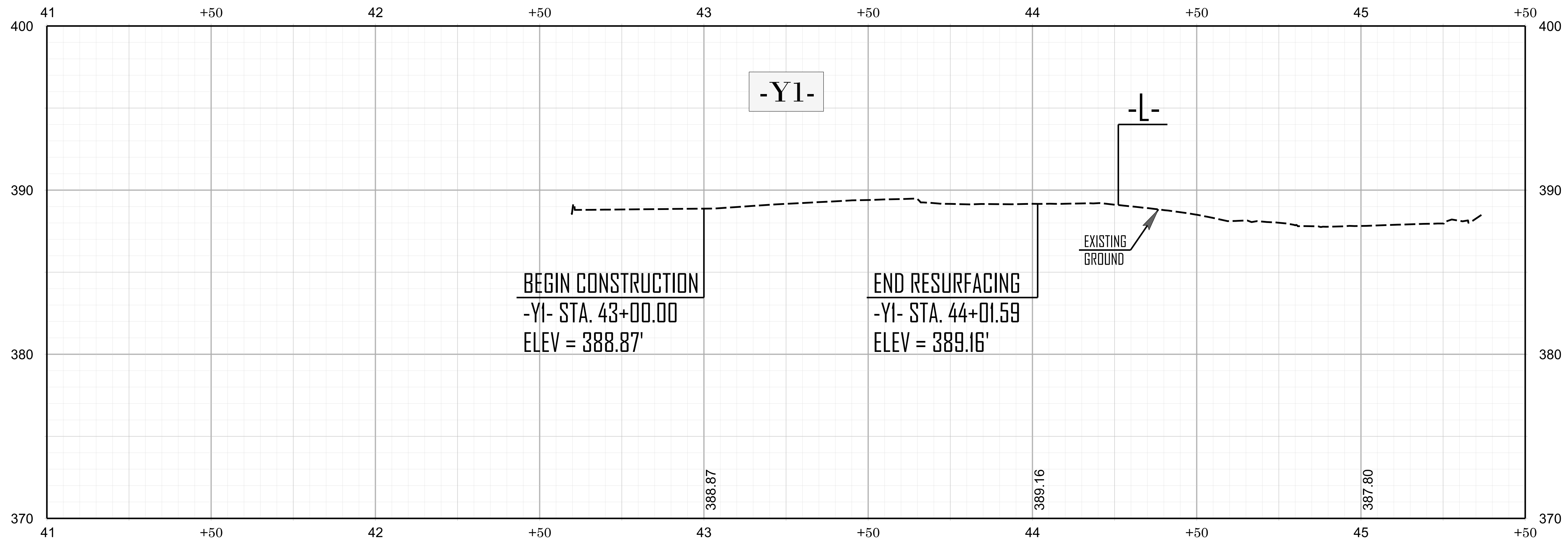
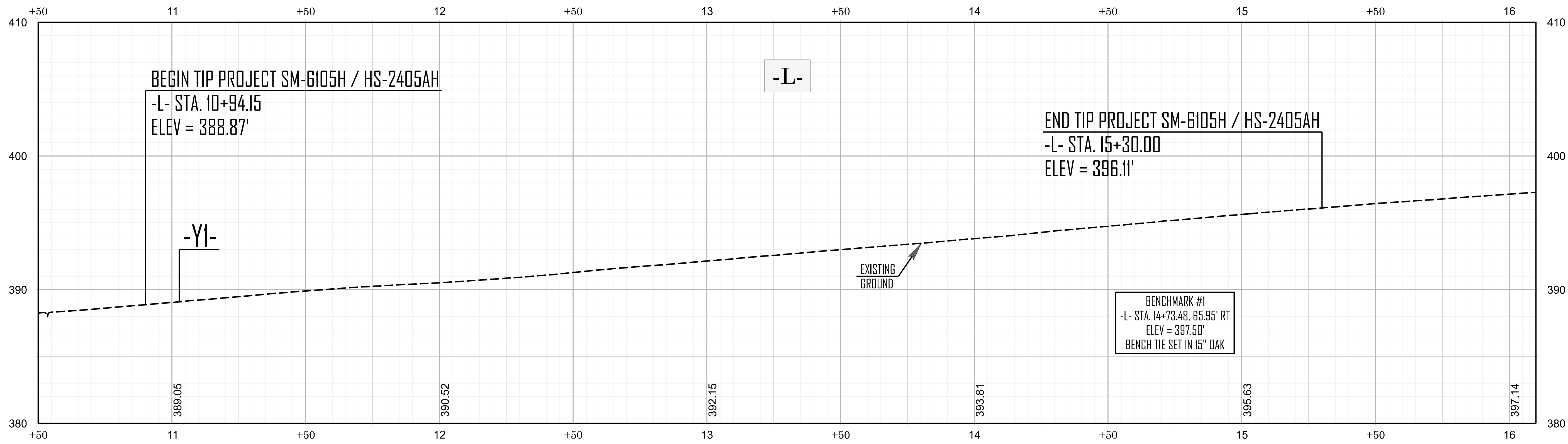

FOR -L- PLAN SEE SHEET 4.
 FOR -Y1- PLAN SEE SHEET 4.

SM-6105H / HS-2405AH

4R01 | 5

NORTH CAROLINA
 DEPARTMENT OF TRANSPORTATION
 DURHAM COUNTY

ROADWAY DESIGN UNIT
 ROADWAY DESIGN ENGINEER

12/19/2023
 NORTH CAROLINA PROFESSIONAL SEAL
 SEAL 038649
 ENGINEER
 MATTHEW A. DOUGLAS

12/22/2023
 NORTH CAROLINA PROFESSIONAL SEAL
 SEAL 053425
 ENGINEER
 MATTHEW L. HARVEY

ROADWAY DESIGN PREPARED BY
VIAS INFRASTRUCTURE
 220 HORIZON DRIVE, SUITE 117
 RALEIGH, NC 27615
 PHONE (777) 214-7668
 LICENSE NO P-2673
 WWW.VIASINFRASTRUCTURE.COM

HYDRAULIC DESIGN PREPARED BY
WETHERILL ENGINEERING
 1223 Jones Franklin Rd.
 Raleigh, N.C. 27606
 License No. F-0377
 Bus: 919 851 8077
 Fax: 919 851 8107

REVISIONS

09/08/09

TIP PROJECT: SM-5705AG

STATE OF NORTH CAROLINA DIVISION OF HIGHWAYS

STATE NO.	STATE PROJECT REFERENCE NO.	SHEET NO.	TOTAL SHEETS
N.C.	SM-5705AG	RW01	4

SURVEY CONTROL, EXISTING CENTERLINES, RIGHT OF WAY, EASEMENTS AND PROPERTY TIES

WAKE COUNTY

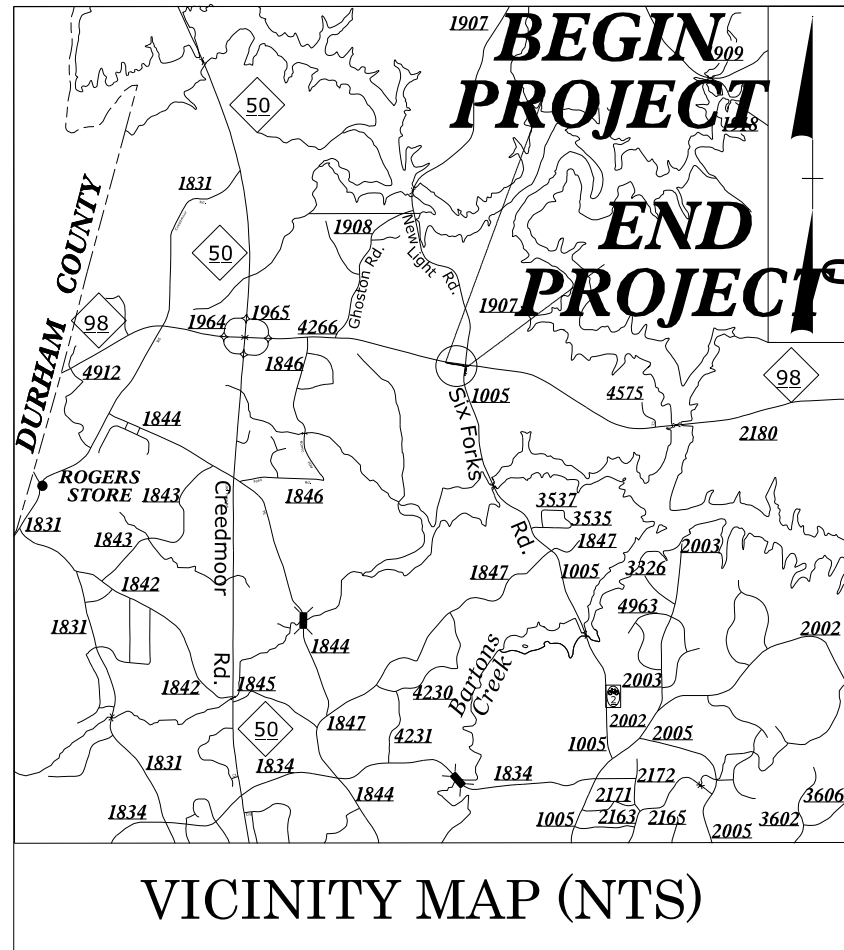

RW04

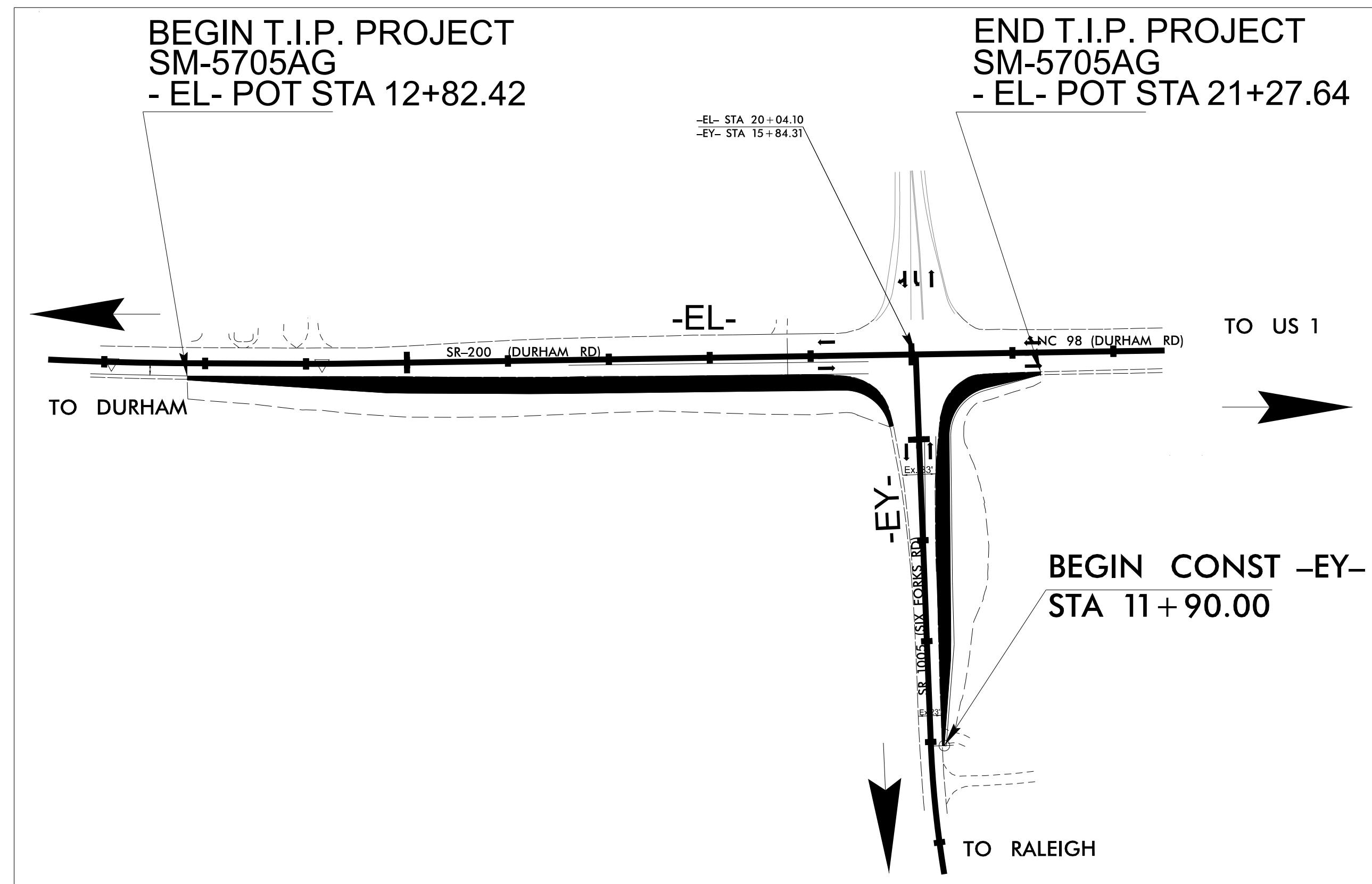

THIS PROJECT IS NOT WITHIN ANY MUNICIPAL BOUNDARIES

DOCUMENT NOT CONSIDERED FINAL
UNLESS ALL SIGNATURES COMPLETED

GRAPHIC SCALES



DATUM DESCRIPTION

THE LOCALIZED COORDINATE SYSTEM DEVELOPED FOR THIS PROJECT IS BASED ON THE STATE PLANE COORDINATES ESTABLISHED BY NCDOT FOR MONUMENT "NCDOT AZ-2" WITH NAD83/2011 STATE PLANE GRID COORDINATES OF NORTHING: 813516.775 EASTING: 2102024.1191 ELEVATION: 348.65

THE AVERAGE COMBINED GRID FACTOR USED ON THIS PROJECT (GROUND TO GRID) IS: 0.9999426955

ALL LINEAR DIMENSIONS ARE LOCALIZED HORIZONTAL DISTANCES

VERTICAL DATUM USED IS NAVD 88

Prepared in the Office of:



PROFESSIONAL LAND SURVEYOR

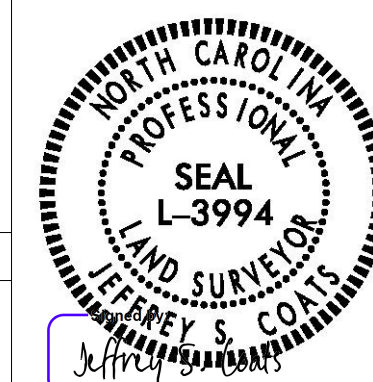

SIGNATURE:

11/5/2025

DATE:

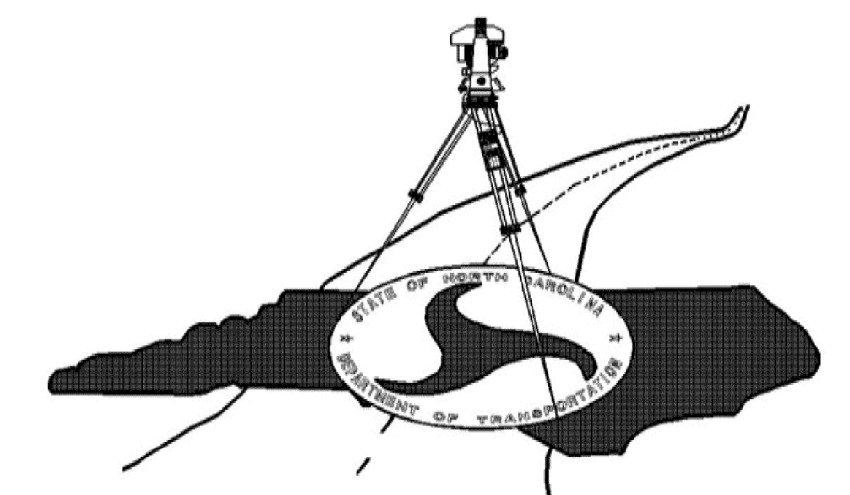

6/2/19

SURVEY CONTROL SHEET

W/ EXISTING CENTERLINE ALIGNMENTS PRIOR TO CONSTRUCTION

PROJECT REFERENCE NO. SM5705AG	SHEET NO. RW02C-1
Location and Surveys	
ESP ASSOCIATES, INC. 2200 GATEWAY CENTRE BLVD. SUITE 216 MORRISVILLE, NC 27560	
PROJECT SURVEYOR: TOYNIA E.S. GIBBS	
 LICENSE NO. F-1407	
DOCUMENT NOT CONSIDERED FINAL UNLESS ALL SIGNATURES COMPLETED	

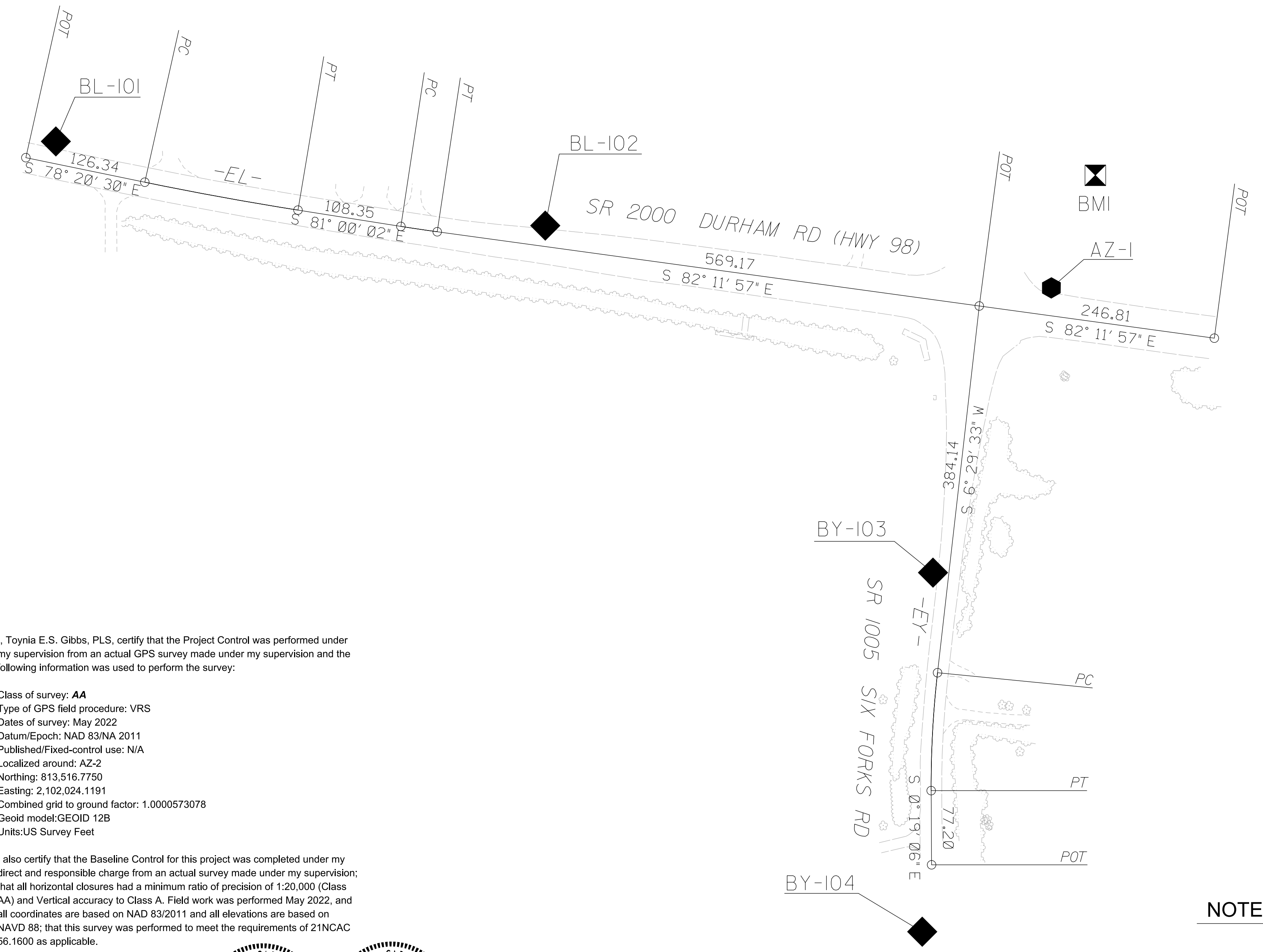

I, Toynia E.S. Gibbs, PLS, certify that the Project Control was performed under my supervision from an actual GPS survey made under my supervision and the following information was used to perform the survey:

Class of survey: **AA**
 Type of GPS field procedure: VRS
 Dates of survey: May 2022
 Datum/Epoch: NAD 83/NA 2011
 Published/Fixed-control use: N/A
 Localized around: AZ-2
 Northing: 813,516.7750
 Easting: 2,102,024.1191
 Combined grid to ground factor: 1.0000573078
 Geoid model: GEOID 12B
 Units: US Survey Feet

I also certify that the Baseline Control for this project was completed under my direct and responsible charge from an actual survey made under my supervision; that all horizontal closures had a minimum ratio of precision of 1:20,000 (Class AA) and Vertical accuracy to Class A. Field work was performed May 2022, and all coordinates are based on NAD 83/2011 and all elevations are based on NAVD 88; that this survey was performed to meet the requirements of 21NCAC 56.1600 as applicable.

This day of 5/27/2022

Designed by:

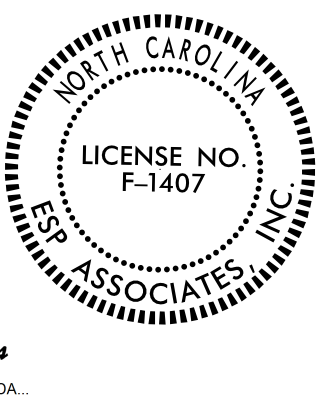
 Professional Land Surveyor L-3866



Designed by:

 2E2F55A0E0C8DA

NOTES:

- PROJECT CONTROL WAS ESTABLISHED USING GNSS, THE GLOBAL NAVIGATION SATELLITE SYSTEM.
- THE SURVEY CONTROL DATA FOR THIS PROJECT HAS BEEN COMPILED FROM VARIOUS SOURCES. IF FURTHER INFORMATION REGARDING PROJECT CONTROL IS NEEDED, PLEASE CONTACT THE LOCATION AND SURVEYS UNIT.

REVISIONS

27-MAY-2022 08:20
 S:\Projects\2022\RS2\JM01085 SM5705AG.con.esp Full Surveys\Location\Control Sheets\150.003.SM5705AG.ls_RW02C-1.dgn
 ngreene AT ESP\S2102218

6/2/19

SURVEY CONTROL SHEET

W/ EXISTING CENTERLINE ALIGNMENTS PRIOR TO CONSTRUCTION

PROJECT REFERENCE NO. SM5705AG	SHEET NO. RW02C-2
Location and Surveys	
ESP ASSOCIATES, INC. 2200 GATEWAY CENTRE BLVD. SUITE 216 MORRISVILLE, NC 27560	
PROJECT SURVEYOR: TOYNIA E.S. GIBBS	
LICENSE NO. F-1407	
DOCUMENT NOT CONSIDERED FINAL UNLESS ALL SIGNATURES COMPLETED	

BL	POINT	DESC.	NORTH	EAST	ELEVATION
	101	BL - 101	813806.1536	2100018.9162	376.51
	102	BL - 102	813718.5383	2100528.0344	369.10
	1	AZ - 1	813653.7750	2101054.6086	357.39
	2	AZ - 2	813516.7750	2102024.1191	348.65

BY	POINT	DESC.	NORTH	EAST	ELEVATION
	103	BY - 103	813357.3803	2100931.3703	363.80
	104	BY - 104	812983.6604	2100920.1812	365.81

 BM1 ELEVATION = 364.12
 N 813771 E 2101100
 BM-1 - 24" PINE

I, Toynia E.S. Gibbs, PLS, certify that the Project Control was performed under my supervision from an actual GPS survey made under my supervision and the following information was used to perform the survey:

Class of survey: **AA**
 Type of GPS field procedure: VRS
 Dates of survey: May 2022
 Datum/Epoch: NAD 83/NA 2011
 Published/Fixed-control use: N/A
 Localized around: AZ-2
 Northing: 813,516.7750
 Easting: 2,102,024.1191
 Combined grid to ground factor: 1.0000573078
 Geoid model: GEOID 12B
 Units: US Survey Feet

I also certify that the Baseline Control for this project was completed under my direct and responsible charge from an actual survey made under my supervision; that all horizontal closures had a minimum ratio of precision of 1:20,000 (Class AA) and Vertical accuracy to Class A. Field work was performed May 2022, and all coordinates are based on NAD 83/2011 and all elevations are based on NAVD 88; that this survey was performed to meet the requirements of 21NCAC 56.1600 as applicable.

This day of 5/27/2022
 DocuSigned by:

 Toynia Gibbs
 Professional Land Surveyor L-3866

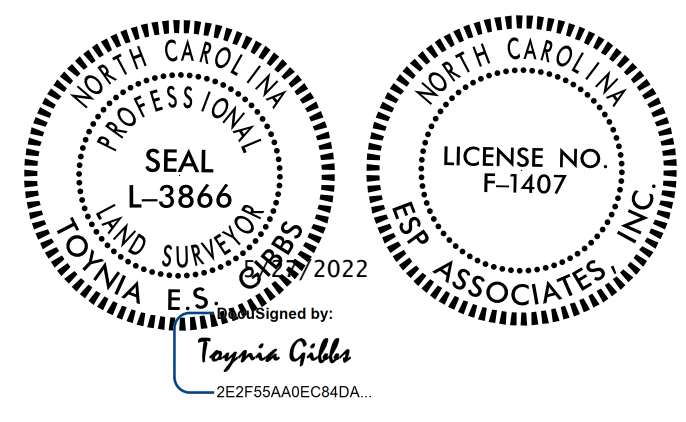

EL									
POINT	N	E	BEARING	DIST	DELTA	D	L	T	R
POT	813789.286	2099987.780	S 78°20'30.5" E	126.34					
LINE									
PC	813763.756	2100111.514	S 79°40'16.4" E	162.00	02°39'31.9"(LT)	01°38'28.2"	162.01	81.02	3491.18
CURVE									
PT	813734.711	2100270.886	S 81°00'02.4" E	108.35					
LINE									
PC	813717.762	2100377.900	S 81°35'59.9" E	38.24	01°11'55.0"(LT)	03°08'04.2"	38.24	19.12	1827.91
CURVE									
PT	813712.176	2100415.729	S 82°11'57.4" E	569.17					
LINE									
POT	813634.925	2100979.627	S 82°11'57.4" E	246.81					
LINE									
POT	813601.426	2101224.154							

EY									
POINT	N	E	BEARING	DIST	DELTA	D	L	T	R
POT	813634.925	2100979.627	S 06°29'33.3" W	384.14					
LINE									
PC	813253.251	2100936.191	S 03°05'13.7" W	122.90	06°48'39.1"(LT)	05°32'18.0"	122.98	61.56	1034.53
CURVE									
PT	813130.525	2100929.572	S 00°19'05.8" E	77.20					
LINE									
POT	813053.330	2100930.001							

NOTES:

1. PROJECT CONTROL WAS ESTABLISHED USING GNSS, THE GLOBAL NAVIGATION SATELLITE SYSTEM.
2. THE SURVEY CONTROL DATA FOR THIS PROJECT HAS BEEN COMPILED FROM VARIOUS SOURCES. IF FURTHER INFORMATION REGARDING PROJECT CONTROL IS NEEDED, PLEASE CONTACT THE LOCATION AND SURVEYS UNIT.

REVISIONS

27-MAY-2022 08:22 S:\Projects\2022\RS2\JM01\085 SM5705AG.con.esp Full Surveys\Location\Control Sheets\150.006 SM5705AG_1s_RW02C-2.dgn
 ngreene AT ESP52102218

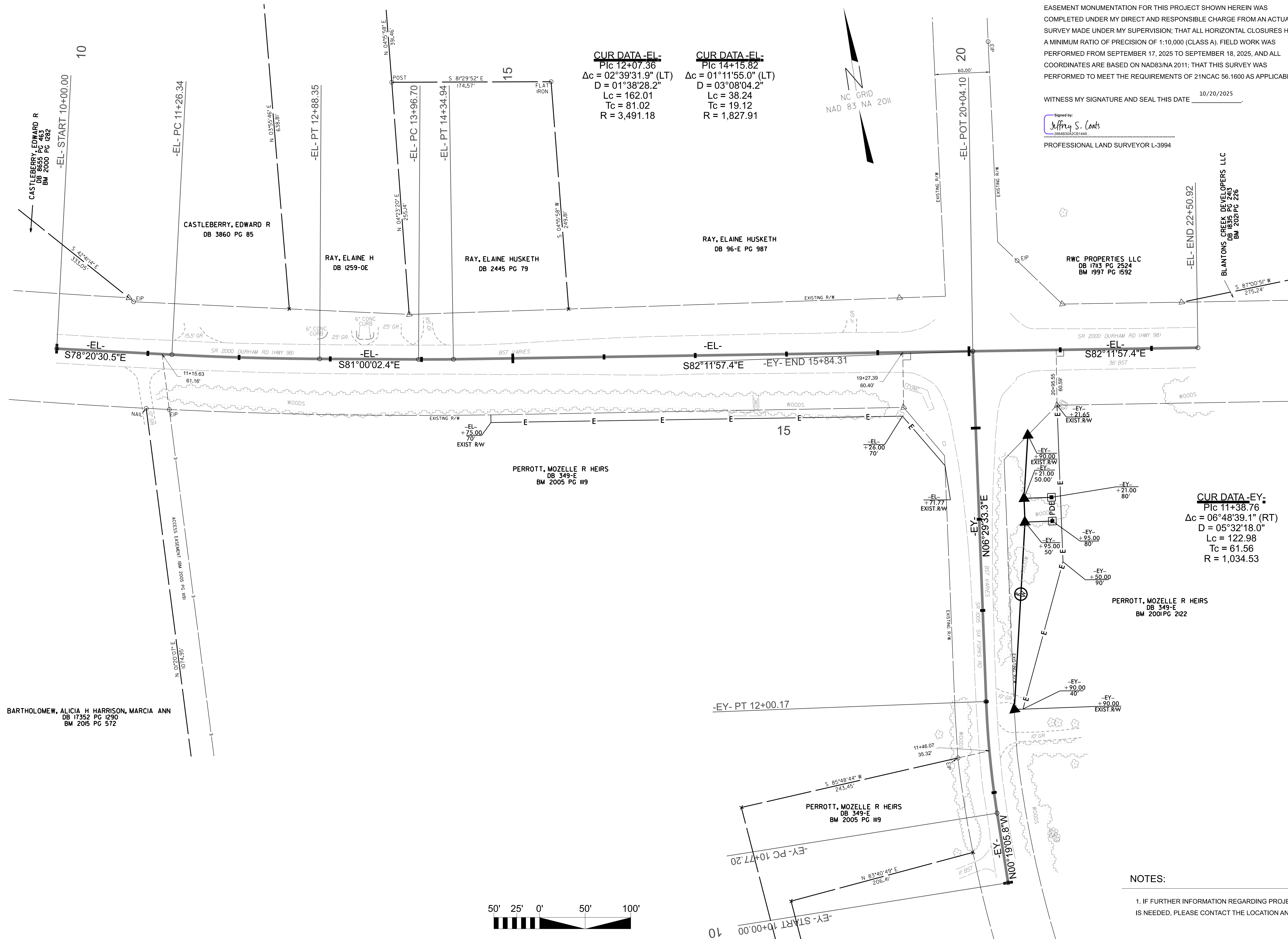

CUR DATA -EL-
 P/c 12+07.36
 $\Delta c = 02^{\circ}39'31.9"$ (LT)
 $D = 01^{\circ}38'28.2"$
 $Lc = 162.01$
 $Tc = 81.02$
 $R = 3,491.18$

CUR DATA -EL-
 P/c 14+15.82
 $\Delta c = 01^{\circ}11'55.0"$ (LT)
 $D = 03^{\circ}08'04.2"$
 $Lc = 38.24$
 $Tc = 19.12$
 $R = 1,827.91$



I, JEFFREY S. COATS, PLS, CERTIFY THAT THE RIGHT OF WAY AND PERMANENT EASEMENT MONUMENTATION FOR THIS PROJECT SHOWN HEREIN WAS COMPLETED UNDER MY DIRECT AND RESPONSIBLE CHARGE FROM AN ACTUAL SURVEY MADE UNDER MY SUPERVISION; THAT ALL HORIZONTAL CLOSURES HAD A MINIMUM RATIO OF PRECISION OF 1:10,000 (CLASS A). FIELD WORK WAS PERFORMED FROM SEPTEMBER 17, 2025 TO SEPTEMBER 18, 2025, AND ALL COORDINATES ARE BASED ON NAD83/NA 2011; THAT THIS SURVEY WAS PERFORMED TO MEET THE REQUIREMENTS OF 21NCAC 56.1600 AS APPLICABLE.

WITNESS MY SIGNATURE AND SEAL THIS DATE 10/20/2025

Signed by:
 Jeffrey S. Coats
 266483042CB1440
 PROFESSIONAL LAND SURVEYOR L-3994

CUR DATA -EY-
 P/c 11+38.76
 $\Delta c = 06^{\circ}48'39.1"$ (RT)
 $D = 05^{\circ}32'18.0"$
 $Lc = 122.98$
 $Tc = 61.56$
 $R = 1,034.53$

BARTHOLOMEW, ALICIA H HARRISON, MARCIA ANN
 DB 17352 PG 1290
 BM 2015 PG 572



NOTES:
 1. IF FURTHER INFORMATION REGARDING PROJECT CONTROL IS NEEDED, PLEASE CONTACT THE LOCATION AND SURVEYS UNIT.

SM5705AG

R/W 04
 NORTH CAROLINA DEPARTMENT OF TRANSPORTATION

PROFESSIONAL LAND SURVEYOR

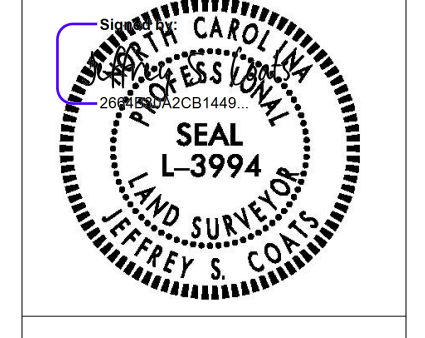

DOCUMENT NOT CONSIDERED FINAL UNLESS ALL SIGNATURES ARE COMPLETED
 2024 STANDARD SPECIFICATIONS

TIP PROJECT: SM-5705AG
 County: Wake

PREPARED FOR

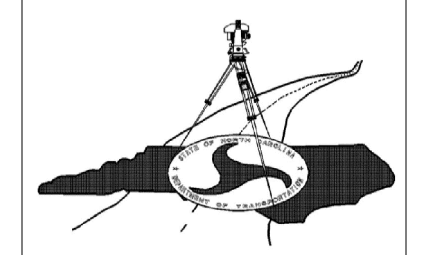

LOCATION AND SURVEYS UNIT

PREPARED BY

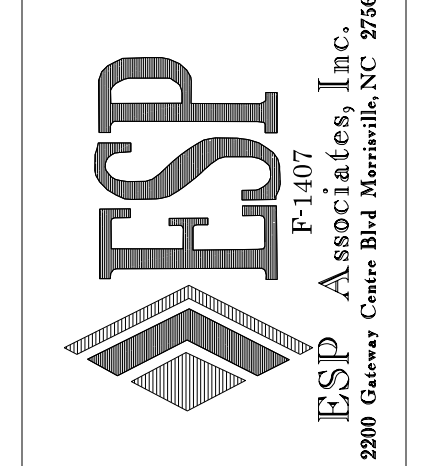

ESP Associates, Inc.
 F-1407
 2200 Greene Center Blvd. Morrisville, NC 27560

PROPOSED ALIGNMENT CONTROL SHEET

I, JEFFREY S. COATS, PLS, CERTIFY THAT THE DATA COMPILED CAME FROM AVAILABLE SURVEYS/MAPPING PERFORMED BY OTHERS AND PROVIDED TO ME BY NCDOT AND DO NOT CERTIFY TO THE ACCURACY OR QUALITY OF THE INDIVIDUAL DATA SOURCES.

WITNESS MY SIGNATURE AND SEAL THIS DATE 10/13/2025

Signed by:
Jeffrey S. Coats

PROFESSIONAL LAND SURVEYOR L-3994

SM5705AG

R/W 020-1

NORTH CAROLINA
DEPARTMENT
OF TRANSPORTATION

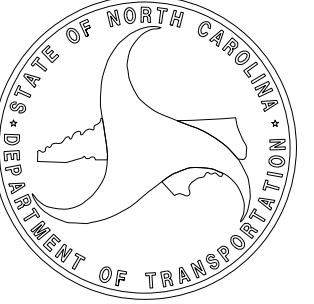

PROFESSIONAL LAND
SURVEYOR



DOCUMENT NOT CONSIDERED
FINAL UNLESS ALL SIGNATURES
ARE COMPLETED

2024 STANDARD
SPECIFICATIONS

TIP PROJECT: SM-5705AG
County: Wake

PROPOSED ALIGNMENT: EL												
POINT	STATION	NORTHING	EASTING	BEARING	DIST	DELTA	D	L	T	R	LT	ST
START	10+00.00	813789.2860	2099987.7800	S78°20'30.5"E	126.34'							
PC	11+26.34	813763.7561	2100111.5140	S79°40'16.4"E	162.00'	02°39'31.9"	01°38'28.2"	162.01'	81.02'	3491.18'		
PT	12+88.35	813734.7107	2100270.8860	S81°00'02.4"E	108.35'							
PC	13+96.70	813717.7624	2100377.9010	S81°35'59.9"E	38.24'	01°11'55.0"	03°08'04.2"	38.24'	19.12'	1827.91'		
PT	14+34.94	813712.1764	2100415.7290	S82°11'57.4"E	569.17'							
HPI	20+04.10	813634.9247	2100979.6270	S82°11'57.4"E	246.81'							
END	22+50.92	813601.4256	2101224.1540									

PROPOSED ALIGNMENT: EY												
POINT	STATION	NORTHING	EASTING	BEARING	DIST	DELTA	D	L	T	R	LT	ST
START	10+00.00	813053.3301	2100930.0011	N00°19'05.8"W	77.20'							
PC	10+77.20	813130.5252	2100929.5722	N03°05'13.7"E	122.90'	06°48'39.1"	05°32'18.0"	122.98'	61.56'	1034.53'		
PT	12+00.17	813253.2511	2100936.1912	N06°29'33.3"E	384.14'							
END	15+84.31	813634.9247	2100979.6273									

NOTES:

1. THE PROPOSED ALIGNMENT CONTROL DATA FOR THIS PROJECT HAS BEEN COMPILED FROM VARIOUS SOURCES. IF FURTHER INFORMATION REGARDING PROJECT CONTROL IS NEEDED, PLEASE CONTACT THE LOCATION AND SURVEYS UNIT.

PREPARED FOR

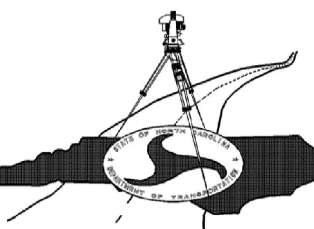

LOCATION AND
SURVEYS UNIT

PREPARED BY

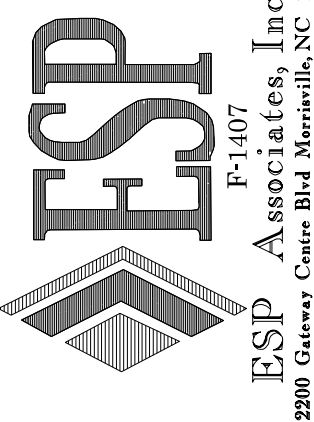

ESP Associates, Inc.
P-1407
2900 Gateway Centre Blvd
Merrillville, NC 27560

RIGHT OF WAY CONTROL SHEET

I, JEFFREY S. COATS, PLS, CERTIFY THAT THE RIGHT OF WAY AND PERMANENT EASEMENT MONUMENTATION FOR THIS PROJECT SHOWN HEREIN WAS COMPLETED UNDER MY DIRECT AND RESPONSIBLE CHARGE FROM AN ACTUAL SURVEY MADE UNDER MY SUPERVISION; THAT ALL HORIZONTAL CLOSURES HAD A MINIMUM RATIO OF PRECISION OF 1:10,000 (CLASS A). FIELD WORK WAS PERFORMED FROM SEPTEMBER 17, 2025 TO SEPTEMBER 18, 2025, AND ALL COORDINATES ARE BASED ON NAD83/NA 2011; THAT THIS SURVEY WAS PERFORMED TO MEET THE REQUIREMENTS OF 21NCAC 56.1600 AS APPLICABLE.

WITNESS MY SIGNATURE AND SEAL THIS DATE 10/13/2025

Signed by:
Jeffrey S. Coats

PROFESSIONAL LAND SURVEYOR L-3994

ROW MARKER IRON PIN AND CAP: EY			
STATION	OFFSET	NORTH	EAST
11+89.89	30.63'	813239.8696	2100965.5412
13+94.85	50.00'	813441.0257	2101007.8852
14+20.85	50.00'	813466.8590	2101010.8251
14+89.85	56.80'	813534.6472	2101025.3864

PERMANENT EASEMENT MARKER IRON PIN AND CAP: EY			
STATION	OFFSET	NORTH	EAST
13+94.93	80.07'	813437.7044	2101037.7703
14+21.07	80.07'	813463.6782	2101040.7263

SM5705AG

R/W 03E-1

NORTH CAROLINA
DEPARTMENT
OF TRANSPORTATION

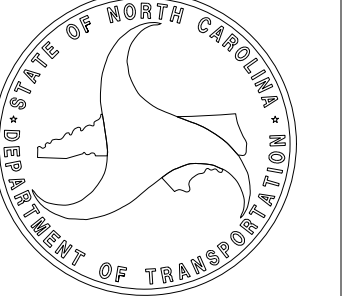

PROFESSIONAL LAND
SURVEYOR



DOCUMENT NOT CONSIDERED
FINAL UNLESS ALL SIGNATURES
ARE COMPLETED

2024 STANDARD
SPECIFICATIONS

TIP PROJECT: SM-5705AG
County: Wake

PREPARED FOR

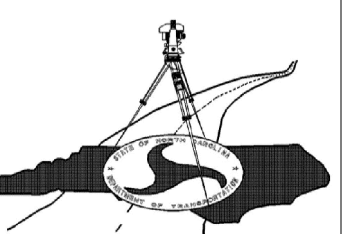

LOCATION AND
SURVEYS UNIT

PREPARED BY

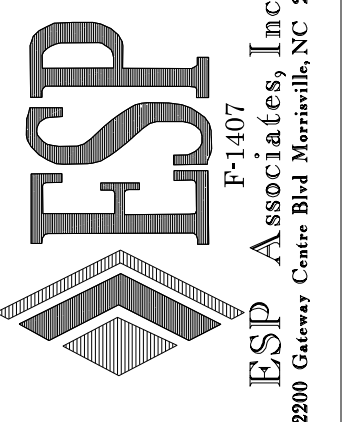

NOTES:

- IF FURTHER INFORMATION REGARDING PROJECT CONTROL IS NEEDED, PLEASE CONTACT THE LOCATION AND SURVEYS UNIT.

STATE	STATE PROJECT REFERENCE NO.	SHEET NO.	TOTAL SHEETS
N.C.	SM-6105H/HS-2405AH	RW01	7

STATE OF NORTH CAROLINA DIVISION OF HIGHWAYS

SURVEY CONTROL, EXISTING CENTERLINES,
RIGHT OF WAY, EASEMENTS AND PROPERTY TIES

DURHAM COUNTY

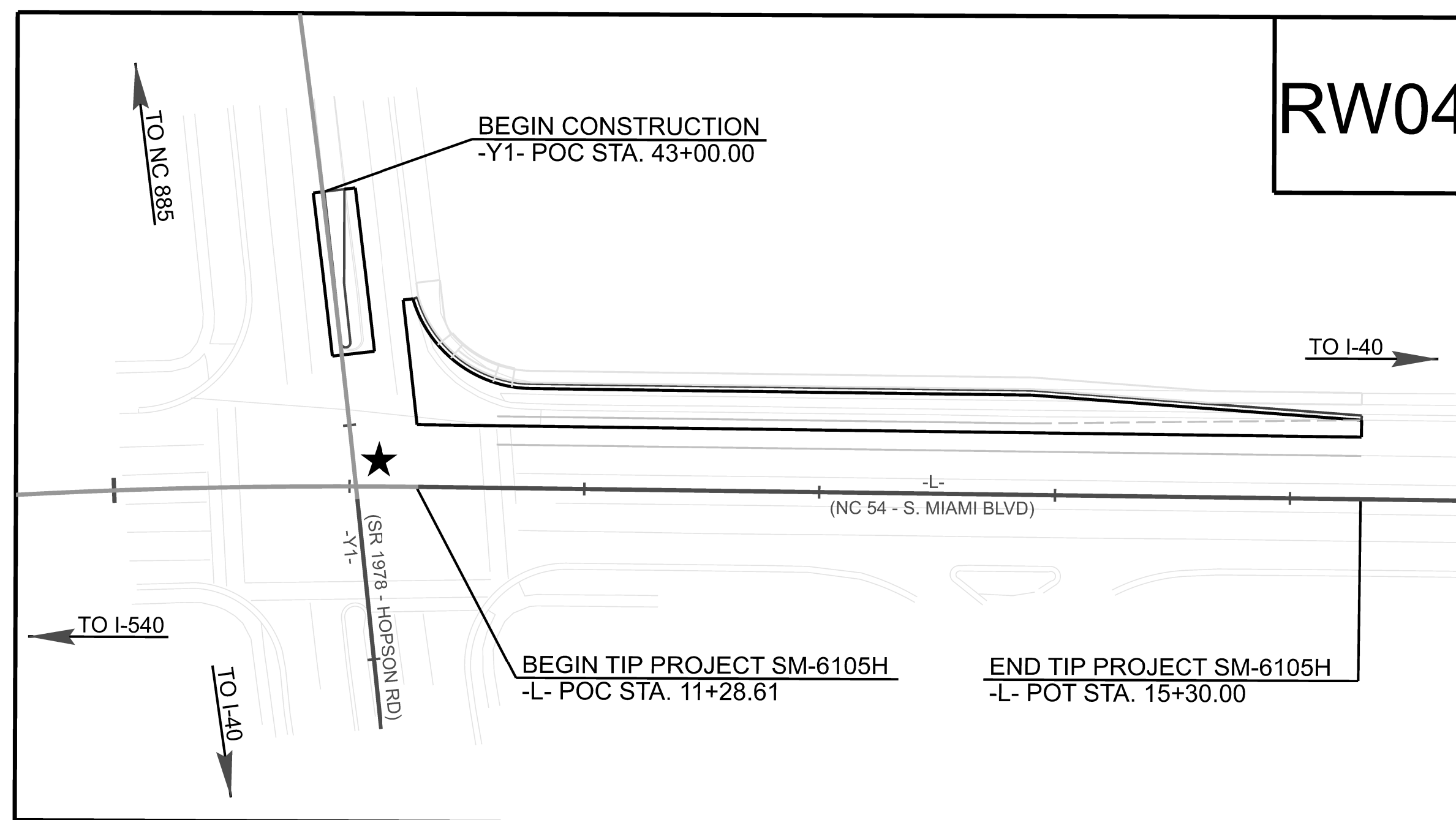
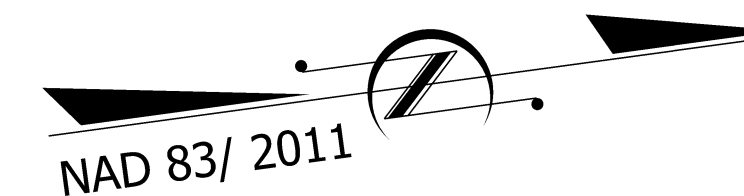
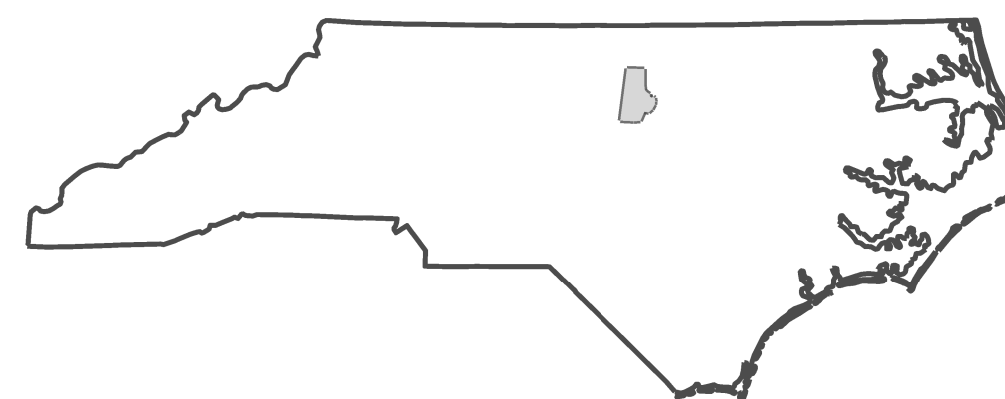
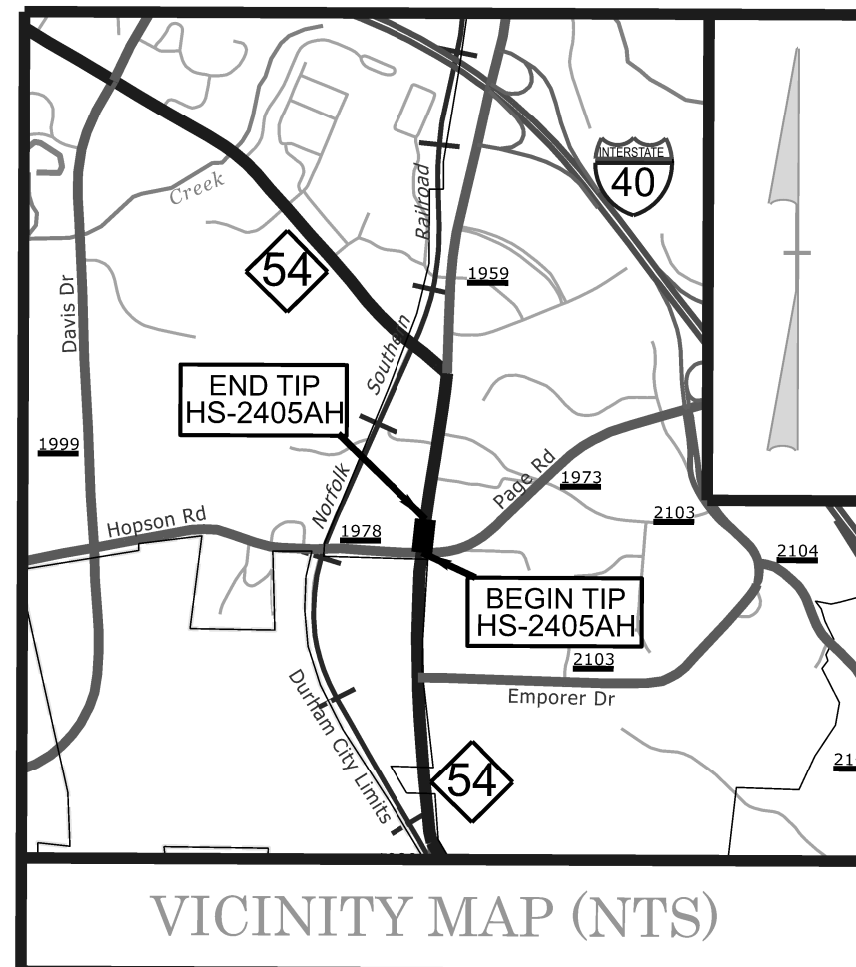

★ REVISED SIGNAL

DOCUMENT NOT CONSIDERED FINAL
UNLESS ALL SIGNATURES COMPLETED

GRAPHIC SCALES



DATUM DESCRIPTION

THE LOCALIZED COORDINATE SYSTEM DEVELOPED FOR THIS PROJECT IS BASED ON THE STATE PLANE COORDINATES ESTABLISHED BY NCDOT FOR MONUMENT SM6105-2 WITH NAD83/2011 STATE PLANE GRID COORDINATES OF NORTHING: 773672.1858 EASTING: 2044143.0633 ELEVATION: 379.44'

THE AVERAGE COMBINED GRID FACTOR USED ON THIS PROJECT (GROUND TO GRID) IS: 0.9999186069

ALL LINEAR DIMENSIONS ARE LOCALIZED HORIZONTAL DISTANCES

VERTICAL DATUM USED IS NAVD 88

Prepared in the Office of:

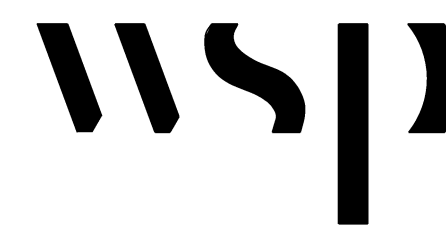

GEOSPHERE LAND SURVEYING OF NC
128 TALBERT ROAD
MOORESVILLE NC 28117
FIRM C-5241

2024 STANDARD SPECIFICATIONS

RIGHT OF WAY DATE:

LETTING DATE:

PROFESSIONAL LAND SURVEYOR

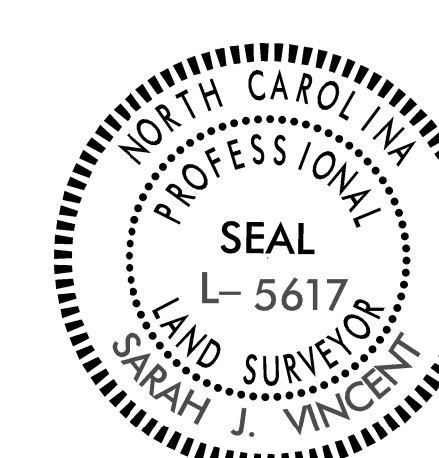

DocuSigned by:
Sarah Vincent
280541789-55548A

11/25/2025
DATE:

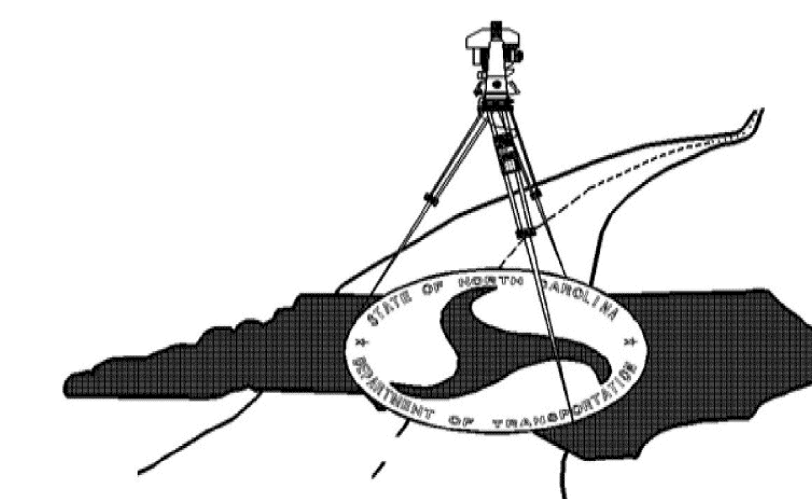

09/08/09

TIP PROJECT: SM-6105H/HS-2405AH

PROPOSED ALIGNMENT CONTROL SHEET

SM-6105H/HS-2405AH

R/W 020-1

NORTH CAROLINA
DEPARTMENT
OF TRANSPORTATION

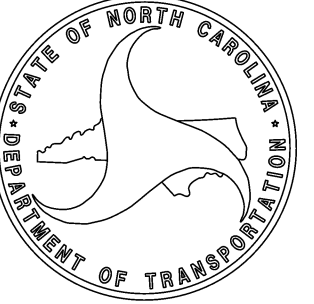

I, Sarah J. Vincent, PLS, CERTIFY THAT THE DATA COMPILED CAME FROM AVAILABLE SURVEYS/MAPPING PERFORMED BY OTHERS AND PROVIDED TO ME BY NCDOT AND DO NOT CERTIFY TO THE ACCURACY OR QUALITY OF THE INDIVIDUAL DATA SOURCES.

THIS 25TH DAY OF NOVEMBER, 2025.

DocuSigned by:
Sarah Vincent

PROFESSIONAL LAND SURVEYOR L-5617

PROFESSIONAL LAND SURVEYOR



DOCUMENT NOT CONSIDERED FINAL UNLESS ALL SIGNATURES ARE COMPLETED

2024 STANDARD SPECIFICATIONS

TIP PROJECT: SM-6105H/HS-2405AH
County: Durham

PROPOSED ALIGNMENT: L												
POINT	STATION	NORTHING	EASTING	BEARING	DIST	DELTA	D	L	T	R	LT	ST
PC	8+50.00	773938.7817	2044120.2620	N05°25'32.2"E	279.38	06°09'34.7"	02°12'13.3"	279.52	139.89	2600.00		
PT	11+29.52	774216.9115	2044146.6784	N08°30'19.5"E	670.48							
END	18+00.00	774880.0214	2044245.8451									

PROPOSED ALIGNMENT: Y1												
POINT	STATION	NORTHING	EASTING	BEARING	DIST	DELTA	D	L	T	R	LT	ST
PC	41+00.00	774193.2394	2043816.7689	S89°29'07.8"E	331.58	02°37'53.6"	00°47'36.9"	331.61	165.83	7220.00		
PT	44+31.61	774190.2618	2044148.3350	S88°10'11.0"E	98.39							
END	45+30.00	774187.1194	2044246.6741									

NOTES:

1. THE PROPOSED ALIGNMENT CONTROL DATA FOR THIS PROJECT HAS BEEN COMPILED FROM VARIOUS SOURCES. IF FURTHER INFORMATION REGARDING PROJECT CONTROL IS NEEDED, PLEASE CONTACT THE LOCATION AND SURVEYS UNIT.

PREPARED FOR

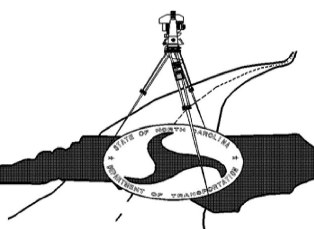

LOCATION AND SURVEYS UNIT

PREPARED BY



GEOSPHERE LAND SURVEYING OF NC
128 TALBERT ROAD
MOORESVILLE NC 28117
FIRM C-5241

RIGHT OF WAY CONTROL SHEET

I, Sarah J. Vincent, PLS, CERTIFY THAT THE RIGHT OF WAY AND PERMANENT EASEMENT MONUMENTATION FOR THIS PROJECT SHOWN HEREIN WAS COMPLETED UNDER MY DIRECT AND RESPONSIBLE CHARGE FROM AN ACTUAL SURVEY MADE UNDER MY SUPERVISION; THAT ALL HORIZONTAL CLOSURES HAD A MINIMUM RATIO OF PRECISION OF 1:10,000 (CLASS A). FIELD WORK WAS PERFORMED ON 10/21/2025, AND ALL COORDINATES ARE BASED ON NAD83/NA 2011; THAT THIS SURVEY WAS PERFORMED TO MEET THE REQUIREMENTS OF 21NCAC 56.1600 AS APPLICABLE.

THIS 25TH DAY OF NOVEMBER, 2025.

DocuSigned by:

 86054178A548A
 PROFESSIONAL LAND SURVEYOR L-5617

SM-6105H/HS-2405AH

R/W 03E-1

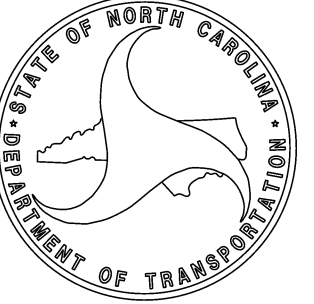
NORTH CAROLINA
 DEPARTMENT
 OF TRANSPORTATION



PROFESSIONAL LAND
 SURVEYOR



DOCUMENT NOT CONSIDERED
 FINAL UNLESS ALL SIGNATURES
 ARE COMPLETED

2024 STANDARD
 SPECIFICATIONS

PERMANENT ROW MARKER IRON PIN AND CAP: L			
STATION	OFFSET	NORTHING	EASTING
11+55.00	-66.50	774251.9507	2044084.6789
13+10.00	-66.50	774405.2460	2044107.6039
13+30.00	-60.00	774424.0646	2044116.9905
13+60.00	-60.00	774453.7347	2044121.4276
15+30.00	-50.00	774620.3860	2044156.4611
15+30.00	-47.72	774620.0481	2044158.7202

POINT FALLS UNDER FENCE - NAIL SET

POINT FALLS IN BUSH - NAIL SET

PERMANENT ROW MARKER IRON PIN AND CAP: Y1			
STATION	OFFSET	NORTHING	EASTING
43+36.00	-46.27	774238.9414	2044053.6229
43+36.00	-47.50	774240.1744	2044053.6460
43+47.00	-47.50	774239.9588	2044064.7163

PERMANENT EASEMENT MARKER IRON PIN AND CAP: L			
STATION	OFFSET	NORTHING	EASTING
11+68.00	-66.50	774264.8077	2044086.6017

POINT FALLS IN CONCRETE - NAIL SET

PERMANENT EASEMENT MARKER IRON PIN AND CAP: Y1			
STATION	OFFSET	NORTHING	EASTING
42+87.00	-46.27	774239.6993	2044004.3148
42+87.00	-53.00	774246.4291	2044004.3950
42+95.00	-53.00	774246.3286	2044012.4531
42+95.00	-46.27	774239.5984	2044012.3655

POINT FALLS IN BRICK WALL - OFFSET SET

NOTES:

- IF FURTHER INFORMATION REGARDING PROJECT CONTROL IS NEEDED, PLEASE CONTACT THE LOCATION AND SURVEYS UNIT.

TIP PROJECT: SM-6105H/HS-2405AH

County: Durham

PREPARED FOR

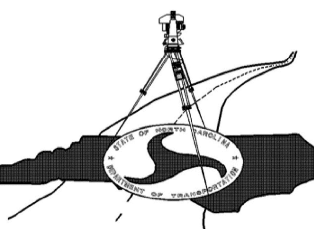

LOCATION AND
 SURVEYS UNIT

PREPARED BY



GEOSPHERE LAND SURVEYING OF NC
 129 TALBERT ROAD
 MOORESVILLE, NC 28117
 FIRM C-5241

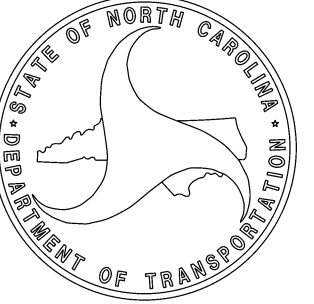

I, Sarah J. Vincent, PLS, CERTIFY THAT THE RIGHT OF WAY AND PERMANENT EASEMENT MONUMENTATION FOR THIS PROJECT SHOWN HEREIN WAS COMPLETED UNDER MY DIRECT AND RESPONSIBLE CHARGE FROM AN ACTUAL SURVEY MADE UNDER MY SUPERVISION; THAT ALL HORIZONTAL CLOSURES HAD A MINIMUM RATIO OF PRECISION OF 1:10,000 (CLASS A). FIELD WORK WAS PERFORMED ON 10/20/2025, AND ALL COORDINATES ARE BASED ON NAD83/NA 2011; THAT THIS SURVEY WAS PERFORMED TO MEET THE REQUIREMENTS OF 21NCAC 56.1600 AS APPLICABLE.

THIS 25TH DAY OF NOVEMBER, 2025.

DocuSigned by: Sarah Vincent

PROFESSIONAL LAND SURVEYOR L-5617

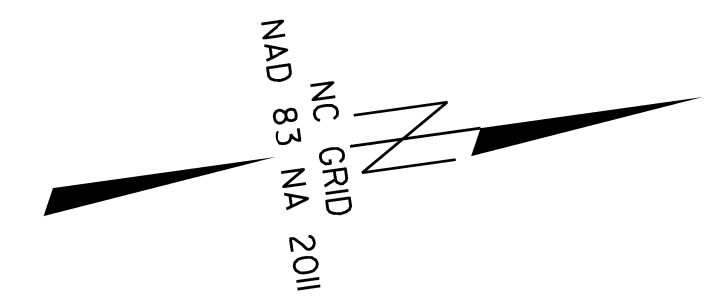
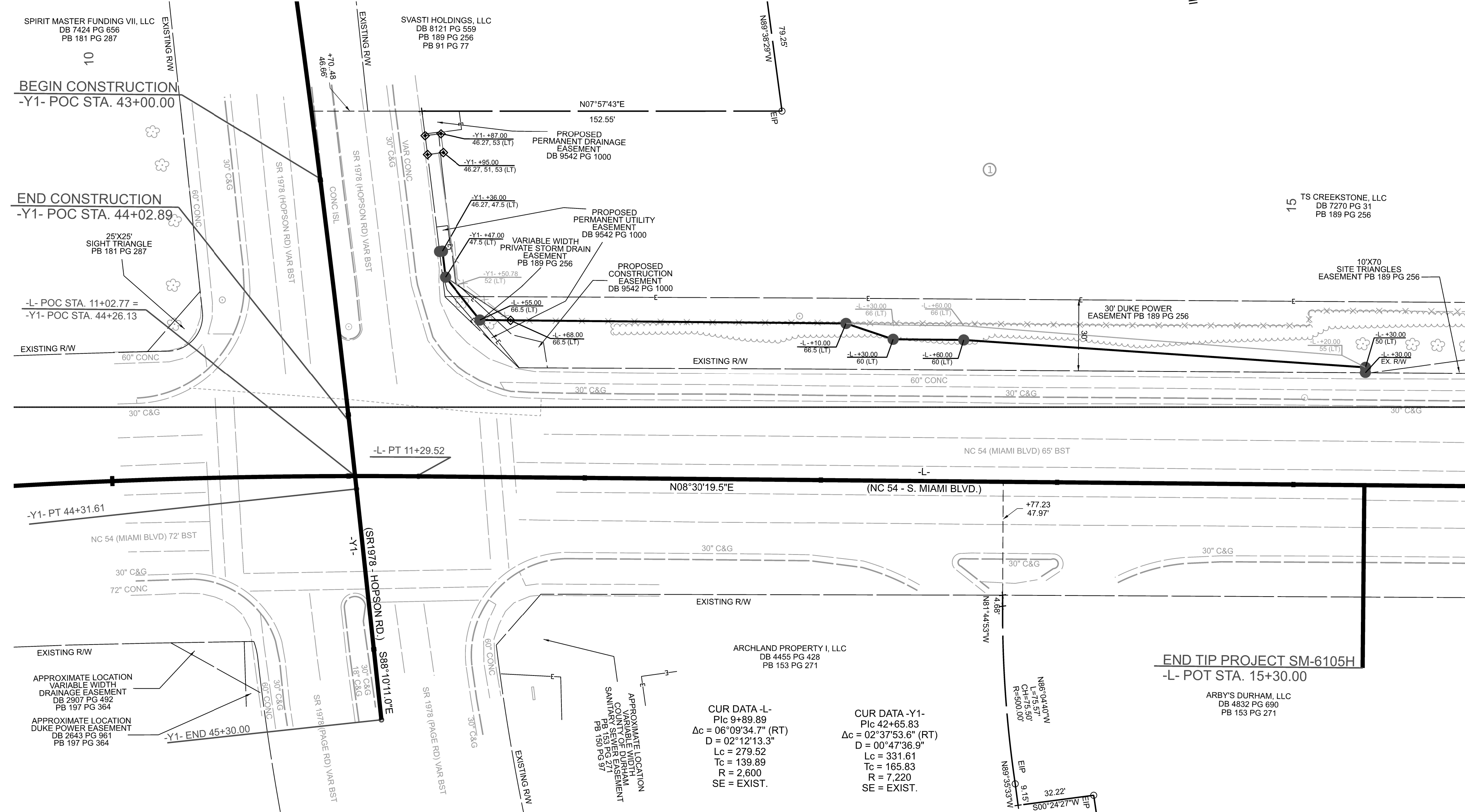

TIP PROJECT: SM-6105H/HS-2405AH
County: Durham

PREPARED FOR

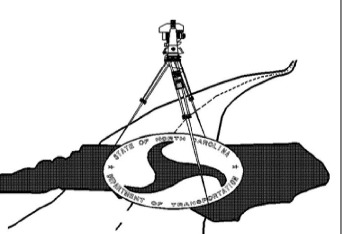

LOCATION AND SURVEYS UNIT

PREPARED BY



GEOSPHERE LAND SURVEYING OF NC
128 TALENT ROAD
MOOREVILLE, NC 28117
FIRM C-5241

NOTES:
1. IF FURTHER INFORMATION REGARDING PROJECT CONTROL IS NEEDED, PLEASE CONTACT THE LOCATION AND SURVEYS UNIT.

SURVEY CONTROL SHEET

W/EXISTING CENTERLINE ALIGNMENTS PRIOR TO CONSTRUCTION

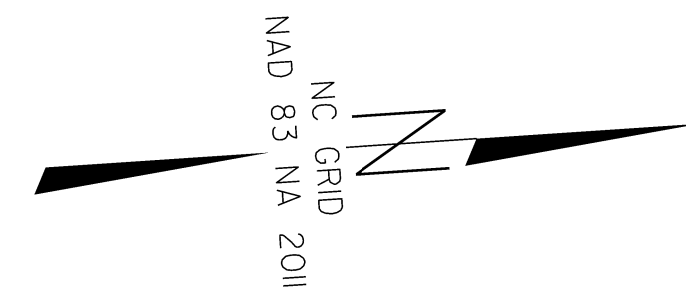

SM6105H-1

SM6105H-2

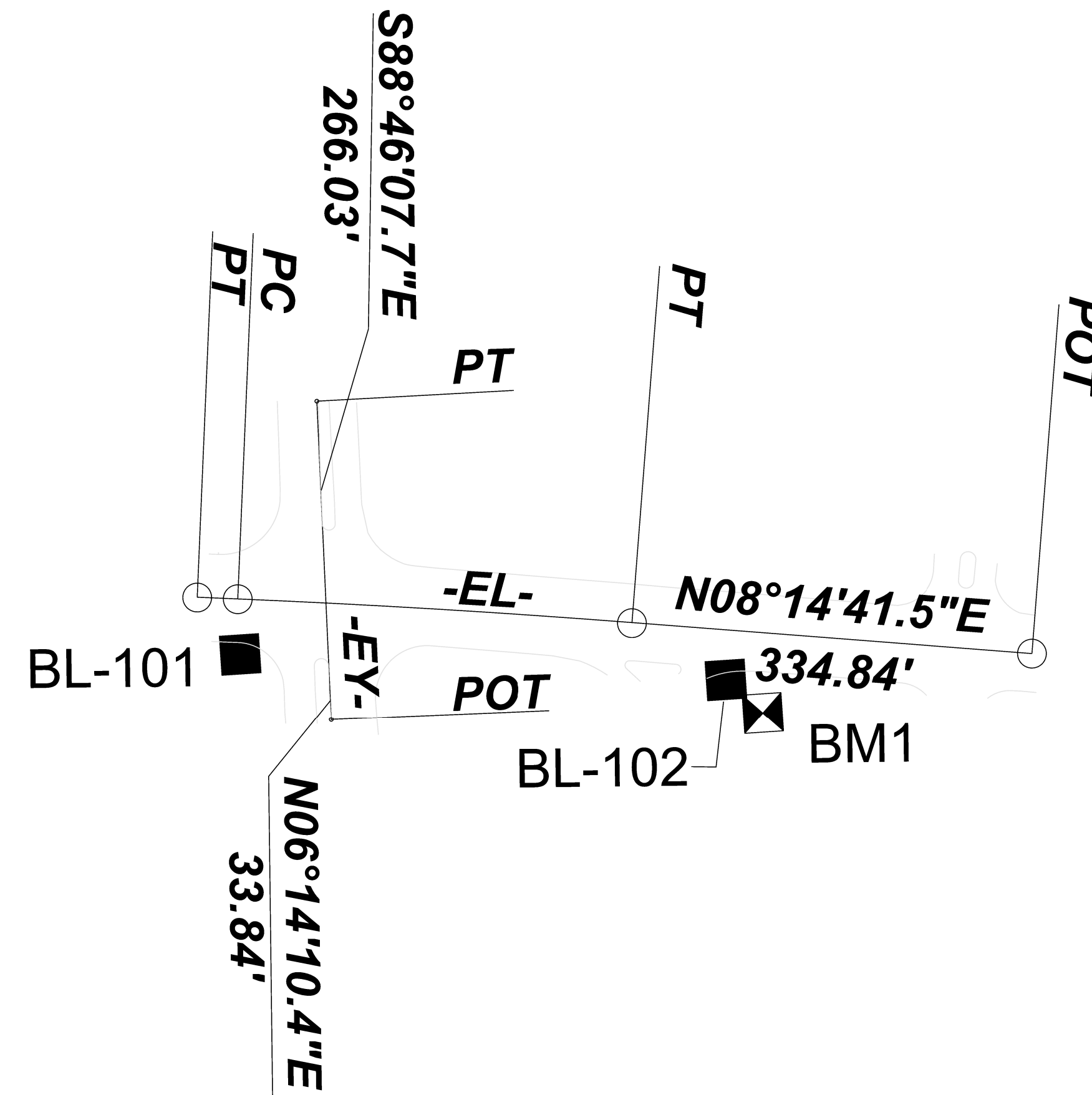

I, Sarah J. Vincent, PLS, certify that the Project Control was performed under my supervision from an actual GPS survey made under my supervision and the following information was used to perform the survey:

Class of survey: AA
Type of GPS field procedure: RTN
Dates of survey: 11/07/2023 - 1/09/2024
Datum/Epoch: NAD83/2011
Published/Fixed-control use: N/A
Localized around: SM6105-2
Northing: 773672.1858
Easting: 2044143.0633
Combined grid factor: 0.9999186069
Geoid model: 18
Units: US Survey Feet

I also certify that the Baseline Control for this project was completed under my direct and responsible charge from an actual survey made under my supervision; that all horizontal closures had a minimum ratio of precision of 1:20,000 (Class AA) and Vertical accuracy to Class A. Field work was performed from 11/07/2023 to 1/09/2024, and all coordinates are based on NAD 83/2011 and all elevations are based on NAVD 88; that this survey was performed to meet the requirements of 21NCAC 56.1600 as applicable.

This 25th day of November, 2025.

DocuSigned by:
Sarah Vincent
992041708A5845A
Professional Land Surveyor L-5617

NOTES:

1. PROJECT CONTROL WAS ESTABLISHED USING GNSS, THE GLOBAL NAVIGATION SATELLITE SYSTEM.
2. THE PROPOSED ALIGNMENT CONTROL DATA FOR THIS PROJECT HAS BEEN COMPILED FROM VARIOUS SOURCES. IF FURTHER INFORMATION REGARDING PROJECT CONTROL IS NEEDED, PLEASE CONTACT THE LOCATION AND SURVEYS UNIT.

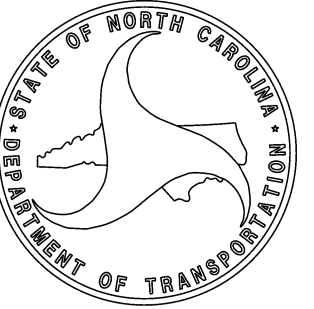

TIP PROJECT: SM-6105H/HS-2405AH
County: Durham

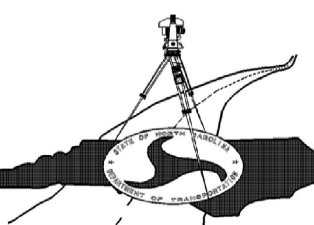

SURVEY CONTROL SHEET

W/EXISTING CENTERLINE ALIGNMENTS PRIOR TO CONSTRUCTION

SM-6105H/HS-2405AH

R/W 0202

NORTH CAROLINA
DEPARTMENT
OF TRANSPORTATION

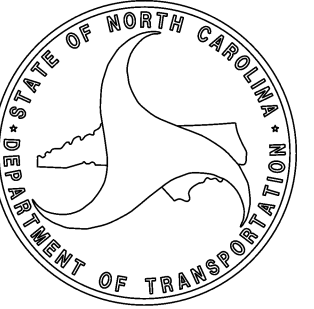

PROFESSIONAL LAND
SURVEYOR



DOCUMENT NOT CONSIDERED
FINAL UNLESS ALL SIGNATURES
ARE COMPLETED

BL POINT	DESC	NORTH	EAST	ELEVATION
1	SM6105H-1	772932.6805	2044159.8057	367.92
2	SM6105H-2	773672.1858	2044143.0633	379.44
101	BL-101	774115.8893	2044183.6818	387.55
102	BL-102	774519.4843	2044232.1753	394.59

BENCHMARKS				
	NORTHING	EASTING	ELEVATION	DESCRIPTION
1	774547	2044263	397.50	BENCH TIE SET IN 15" OAK

I, Sarah J. Vincent, PLS, certify that the Project Control was performed under my supervision from an actual GPS survey made under my supervision and the following information was used to perform the survey:

Class of survey: AA
 Type of GPS field procedure: RTN
 Dates of survey: 11/07/2023 - 1/09/2024
 Datum/Epoch: NAD83/2011
 Published/Fixed-control use: N/A
 Localized around: SM6105-2
 Northing: 773672.1858
 Easting: 2044143.0633
 Combined grid factor: 0.9999186069
 Geoid model: 18
 Units: US Survey Feet

I also certify that the Baseline Control for this project was completed under my direct and responsible charge from an actual survey made under my supervision; that all horizontal closures had a minimum ratio of precision of 1:20,000 (Class AA) and Vertical accuracy to Class A. Field work was performed from 11/07/2023 to 1/09/2024, and all coordinates are based on NAD 83/2011 and all elevations are based on NAVD 88; that this survey was performed to meet the requirements of 21NCAC 56.1600 as applicable.

This 25th day of November, 2025.

DocuSigned by:

 Professional Land Surveyor L-5617

NOTES:

- PROJECT CONTROL WAS ESTABLISHED USING GNSS, THE GLOBAL NAVIGATION SATELLITE SYSTEM.
- THE PROPOSED ALIGNMENT CONTROL DATA FOR THIS PROJECT HAS BEEN COMPILED FROM VARIOUS SOURCES. IF FURTHER INFORMATION REGARDING PROJECT CONTROL IS NEEDED, PLEASE CONTACT THE LOCATION AND SURVEYS UNIT.

TIP PROJECT: SM-6105H/HS-2405AH
 County: Durham

PREPARED FOR

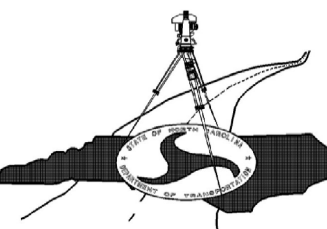

LOCATION AND
SURVEYS UNIT

PREPARED BY



GEOSPHERE LAND SURVEYING OF NC
 129 TALBERT ROAD
 MOORESVILLE NC 28117
 FIRM C-5241

SURVEY CONTROL SHEET

W/EXISTING CENTERLINE ALIGNMENTS PRIOR TO CONSTRUCTION

SM-6105H/HS-2405AH

R/W 0203

NORTH CAROLINA
DEPARTMENT
OF TRANSPORTATION

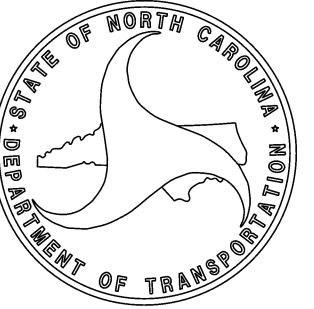

PROFESSIONAL LAND
SURVEYOR

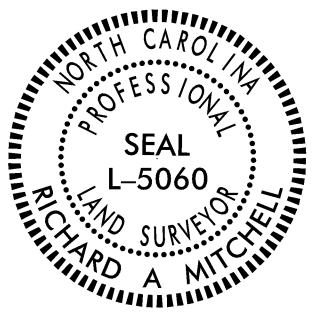

DOCUMENT NOT CONSIDERED
FINAL UNLESS ALL SIGNATURES
ARE COMPLETED

EXISTING ALIGNMENT NAME:EL									
POINT	NORTHING	EASTING	BEARING	DIST	DELTA	D	L	T	R
START	774083.159	2044134.003							
LINE			N06°14'10.4"E	33.84					
PC	774116.799	2044137.679							
CURVE					02°00'31.1" (RT)	00°36'31.9"	329.90	164.97	9410.36
PT	774444.052	2044179.256							
LINE			N08°14'41.5"E	334.84					
END	774775.434	2044227.274							

EXISTING ALIGNMENT NAME:EY									
POINT	NORTHING	EASTING	BEARING	DIST	DELTA	D	L	T	R
START	774193.610	2043978.108							
LINE			S88°46'07.7"E	266.03					
END	774187.894	2044244.076							

I, Sarah J. Vincent, PLS, certify that the Project Control was performed under my supervision from an actual GPS survey made under my supervision and the following information was used to perform the survey:

Class of survey: AA
 Type of GPS field procedure: RTN
 Dates of survey: 11/07/2023 - 1/09/2024
 Datum/Epoch: NAD83/2011
 Published/Fixed-control use: N/A
 Localized around: SM6105-2
 Northing: 773672.1858
 Easting: 2044143.0633
 Combined grid factor: 0.9999186069
 Geoid model: 18
 Units: US Survey Feet

I also certify that the Baseline Control for this project was completed under my direct and responsible charge from an actual survey made under my supervision; that all horizontal closures had a minimum ratio of precision of 1:20,000 (Class AA) and Vertical accuracy to Class A. Field work was performed from 11/07/2023 to 1/09/2024, and all coordinates are based on NAD 83/2011 and all elevations are based on NAVD 88; that this survey was performed to meet the requirements of 21NCAC 56.1600 as applicable.

This 25th day of November, 2025.

DocuSigned by:

 9805175843848A
 Professional Land Surveyor L-5617

NOTES:

- PROJECT CONTROL WAS ESTABLISHED USING GNSS, THE GLOBAL NAVIGATION SATELLITE SYSTEM.
- THE PROPOSED ALIGNMENT CONTROL DATA FOR THIS PROJECT HAS BEEN COMPILED FROM VARIOUS SOURCES. IF FURTHER INFORMATION REGARDING PROJECT CONTROL IS NEEDED, PLEASE CONTACT THE LOCATION AND SURVEYS UNIT.

TIP PROJECT: SM-6105H/HS-2405AH
County: Durham

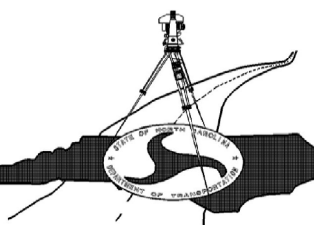
PREPARED FOR



LOCATION AND
SURVEYS UNIT

PREPARED BY



GEOSPHERE LAND SURVEYING OF NC
 128 TALBERT ROAD
 MOORESVILLE NC 28117
 FIRM C-5241

STATE OF NORTH CAROLINA DIVISION OF HIGHWAYS

TRANSPORTATION MANAGEMENT PLAN

DURHAM COUNTY

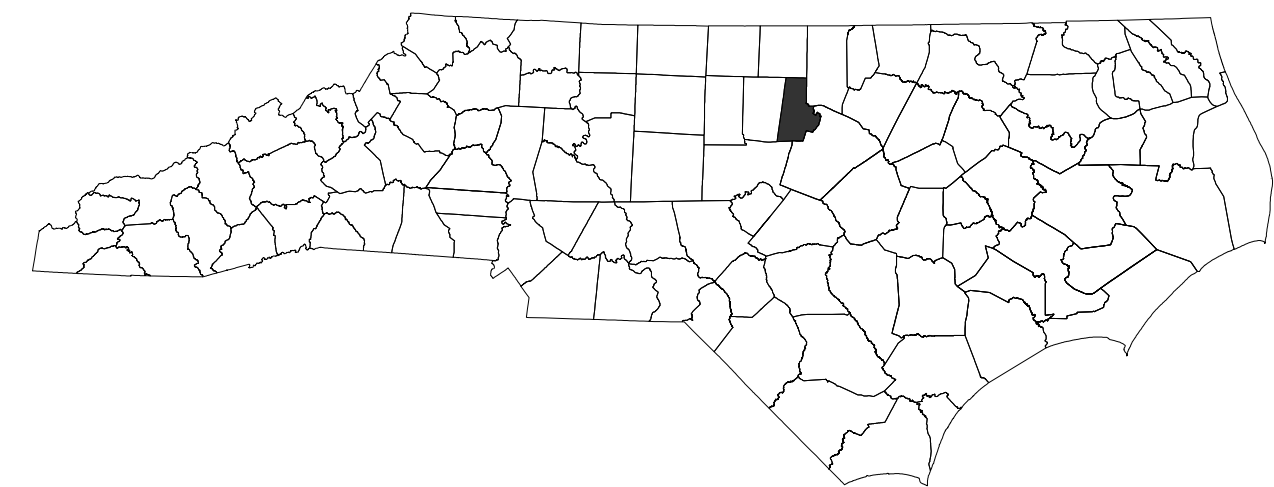

LOCATION: CONSTRUCT A SOUTHBOUND TURN LANE ON
NC 54 (S. MIAMI BLVD) AT SR 1978 (HOPSON RD)

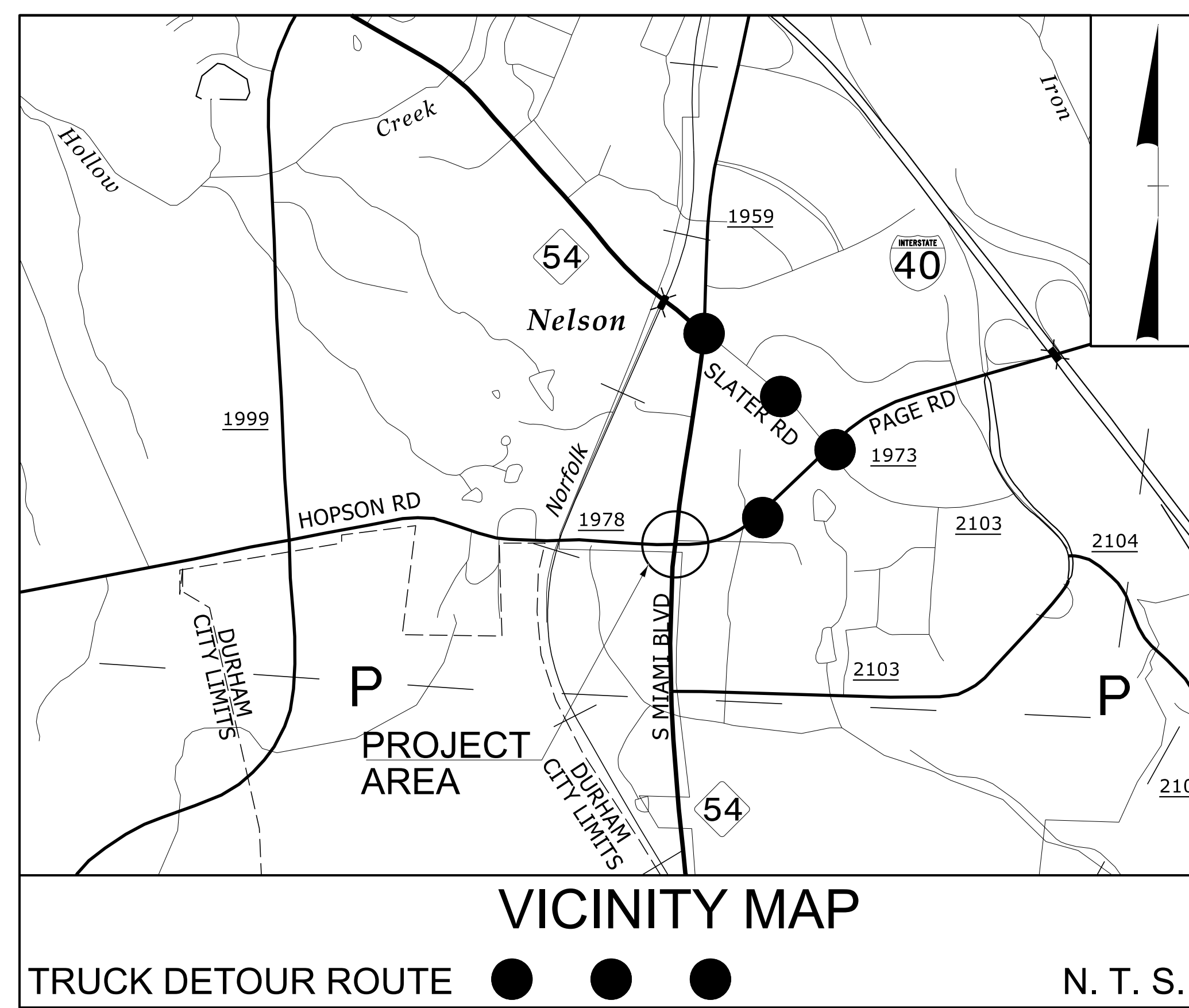

SHEET NO.	TITLE
TMP-1	TITLE SHEET, VICINITY MAP, AND INDEX OF SHEETS
TMP-1A	LIST OF APPLICABLE ROADWAY STANDARD DRAWINGS, AND LEGEND
TMP-1B THRU TMP-1C	TRANSPORTATION OPERATIONS PLAN: (MANAGEMENT STRATEGIES, GENERAL NOTES, AND PHASING)
TMP-2	OFF-SITE TRUCK DETOUR
TMP-2A	SPECIAL SIGN DESIGN
TMP-3	TEMPORARY TRAFFIC CONTROL PHASE II, STEPS 1, 2, AND 3 DETAIL
TMP-4	TEMPORARY TRAFFIC CONTROL PHASE II, STEP 4 DETAIL
TMP-5	TEMPORARY TRAFFIC CONTROL PHASE III, STEPS 1 & 2 DETAIL
TMP-6	TEMPORARY TRAFFIC CONTROL PEDESTRIAN DETOUR

SHEET NO.
TMP-1

12/17/2025 C:\Users\VIAS\Infrastructure\Engineering - Documents\03 Projects\PRJ23008M-NCDS5_SM-6105H04-Design\SM-6105HW\Work Zone Traffic Control\SM-6105H_TTC_TMP01.dgn User:MatthewDouglas



PLANS PREPARED BY:

NICK RAMIREZ, P.E.
PROJECT ENGINEER

MATTHEW DOUGLAS, P.E.
PROJECT DESIGN ENGINEER

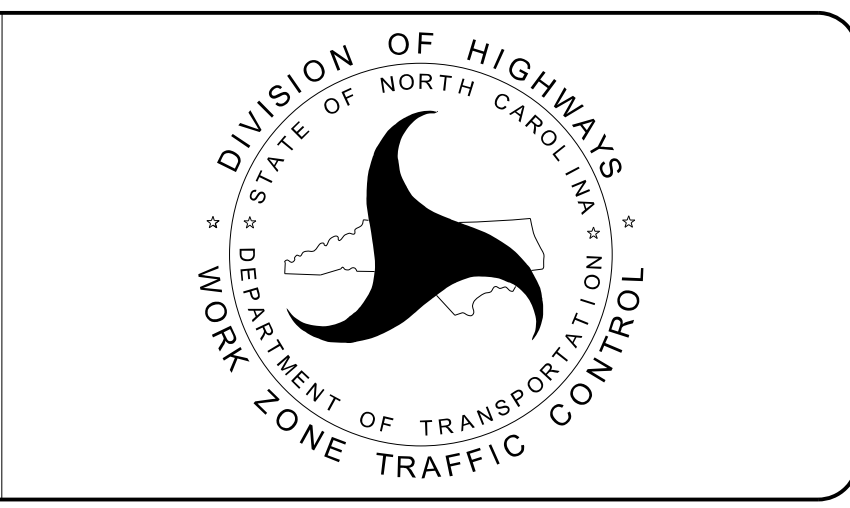

VIAS
INFRASTRUCTURE
220 HORIZON DRIVE, SUITE 117
RALEIGH, NC 27615
PHONE (727) 214-7698
LICENSE NO. P-2673
WWW.VIASINFRASTRUCTURE.COM

**DOCUMENT NOT CONSIDERED FINAL
UNLESS ALL SIGNATURES COMPLETED**

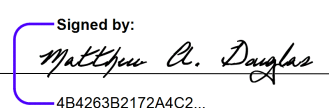
APPROVED: 
DATE: 12/17/2025

SEAL

TIP PROJECT: SM-6105H / HS-2405AH

ROADWAY STANDARD DRAWINGS

THE FOLLOWING ROADWAY STANDARDS AS SHOWN IN "ROADWAY STANDARD DRAWINGS" - N.C. DEPARTMENT OF TRANSPORTATION - RALEIGH, N.C., DATED JANUARY 2024 ARE APPLICABLE TO THIS PROJECT AND BY REFERENCE HEREBY ARE CONSIDERED A PART OF THESE PLANS:

STD. NO.	TITLE
1101.01	WORK ZONE ADVANCE WARNING SIGNS
1101.02	TEMPORARY LANE CLOSURES
1101.04	TEMPORARY SHOULDER CLOSURES
1101.11	TRAFFIC CONTROL DESIGN TABLES
1110.01	STATIONARY WORK ZONE SIGNS
1110.02	PORTABLE WORK ZONE SIGNS
1115.01	FLASHING ARROW BOARDS
1135.01	CONES
1180.01	SKINNY DRUMS
1205.01	PAVEMENT MARKINGS - LINE TYPES AND OFFSETS
1205.02	PAVEMENT MARKINGS - TWO-LANE AND MULTI-LANE ROADWAYS
1205.04	PAVEMENT MARKINGS - INTERSECTIONS
1205.05	PAVEMENT MARKINGS - TURN LANES
1205.07	PAVEMENT MARKINGS - PEDESTRIAN CROSSWALKS
1205.08	PAVEMENT MARKINGS - SYMBOLS AND WORD MESSAGES

LEGEND

GENERAL

- DIRECTION OF TRAFFIC FLOW
- DIRECTION OF PEDESTRIAN TRAFFIC FLOW
- EXIST. PVMT.
- NORTH ARROW
- PROPOSED PVMT.
- TEMP. SHORING (LOCATION PURPOSES ONLY)

- WORK AREA
- REMOVAL
- WEDGE AND/OR WIDEN (USING FLAGGERS)
- TEMPORARY PAVEMENT

SIGNALS

- EXISTING
- PROPOSED
- TEMPORARY

PAVEMENT MARKINGS

- EXISTING LINES
- TEMPORARY LINES

TRAFFIC CONTROL DEVICES

- BARRICADE (TYPE III)
- CONE
- DRUM
- SKINNY DRUM
- TUBULAR MARKER
- TEMPORARY CRASH CUSHION
- FLASHING ARROW BOARD
- FLAGGER
- LAW ENFORCEMENT
- TRUCK MOUNTED ATTENUATOR (TMA)
- CHANGEABLE MESSAGE SIGN
- VARIABLE MESSAGE SIGN
- PORTABLE CONCRETE BARRIER

TEMPORARY SIGNING

- PORTABLE SIGN
- STATIONARY SIGN
- STATIONARY OR PORTABLE SIGN

PAVEMENT MARKING SYMBOLS

- PAVEMENT MARKING SYMBOLS

TEMPORARY PAVEMENT MARKING

PAVEMENT MARKING - PAINT (4")		PAVEMENT MARKING - PAINT (8")	
P1	WHITE EDGELINE	P42	YELLOW DIAGONAL
P2	WHITE SOLID LANE LINE		
P4	3 FT/ 9FT WHITE MINISKIP		
P10	YELLOW EDGELINE		
		PAVEMENT MARKING SYMBOL - PAINT	
		P71	RIGHT TURN ARROW

2/14/2026 C:\Users\VIAS\Infrastructure\Engineering - Documents\03 Projects\PRJ23008M-NC05_SM-6105H\04-Design\SM-6105H\Work Zone Traffic Control\SM-6105H_TTC_TMP01A.dgn User:MatthewDouglas

<p>220 HORIZON DRIVE, SUITE 117 RALEIGH NC 27615 PHONE (727) 214-7698 LICENSE NO. P-2673 WWW.VIASINFRASTRUCTURE.COM</p>	APPROVED: _____ DATE: 2/14/2026			ROADWAY STANDARD DRAWINGS & LEGEND
	Signed by: 4B428382172A4C2			

MANAGEMENT STRATEGIES

THE FOLLOWING LISTED WORK ZONE STRATEGIES ARE RECOMMENDED FOR INCLUSION WITHIN THIS TRANSPORTATION MANAGEMENT PLAN (TMP).

- LANE SHIFTS OR CLOSURES
- WEEKEND WORK
- WORK HOUR RESTRICTIONS FOR PEAK TRAVEL
- PEDESTRIAN/BICYCLE ACCOMMODATIONS
- OFF SITE DETOURS/USE OF ALTERNATIVE ROUTES
- LOCAL DETOUR ROUTES

GENERAL NOTES

CHANGES MAY BE REQUIRED WHEN PHYSICAL DIMENSIONS IN THE DETAIL DRAWINGS, STANDARD DETAILS, AND ROADWAY DETAILS ARE NOT ATTAINABLE TO MEET FIELD CONDITIONS OR RESULT IN DUPLICATE OR UNDESIRED OVERLAPPING OF DEVICES. MODIFICATION MAY INCLUDE: MOVING, SUPPLEMENTING, COVERING, OR REMOVAL OF DEVICES AS DIRECTED BY THE ENGINEER.

THE FOLLOWING GENERAL NOTES APPLY AT ALL TIMES FOR THE DURATION OF THE CONSTRUCTION PROJECT EXCEPT WHEN OTHERWISE NOTED IN THE PLAN OR DIRECTED BY THE ENGINEER.

TIME RESTRICTIONS

A) DO NOT CLOSE OR NARROW TRAVEL LANES AS FOLLOWS:

ROAD NAME	DAY AND TIME RESTRICTIONS
ALL ROADWAYS:	
-L- NC 54 (S. MIAMI BLVD)	MONDAY 6:00 AM TO
-Y1- SR 1978 (HOPSON ROAD)	FRIDAY 7:00 PM

B) DO NOT CLOSE OR NARROW TRAVEL LANES DURING HOLIDAYS AND SPECIAL EVENTS AS FOLLOWS:

ROAD NAME	HOLIDAY
ALL ROADWAYS:	
-L- NC 54 (S. MIAMI BLVD)	
-Y1- SR 1978 (HOPSON ROAD)	
HOLIDAY	
1. FOR ANY UNEXPECTED OCCURRENCE THAT CREATES UNUSUALLY HIGH TRAFFIC VOLUMES, AS DIRECTED BY THE ENGINEER.	
2. FOR NEW YEAR'S, BETWEEN THE HOURS OF 4:00 P.M. DECEMBER 31ST TO 9:00 A.M. JANUARY 2ND. IF NEW YEAR'S DAY IS ON A FRIDAY, SATURDAY, SUNDAY, OR MONDAY THEN UNTIL 9:00 A.M. THE FOLLOWING TUESDAY.	
3. FOR EASTER, BETWEEN THE HOURS OF 4:00 P.M. THURSDAY AND 9:00 A.M. MONDAY.	
4. FOR MEMORIAL DAY, BETWEEN THE HOURS OF 4:00 P.M. FRIDAY TO 9:00 A.M. TUESDAY.	
5. FOR INDEPENDENCE DAY, BETWEEN THE HOURS OF 4:00 P.M. THE DAY BEFORE INDEPENDENCE DAY AND 9:00 A.M. THE DAY AFTER INDEPENDENCE DAY.	
IF INDEPENDENCE DAY IS ON A FRIDAY, SATURDAY, SUNDAY OR MONDAY THEN BETWEEN THE HOURS OF 4:00 P.M. THE THURSDAY BEFORE INDEPENDENCE DAY AND 9:00 A.M. THE TUESDAY AFTER INDEPENDENCE DAY.	
6. FOR LABOR DAY, BETWEEN THE HOURS OF 4:00 P.M. FRIDAY AND 9:00 A.M. TUESDAY.	
7. FOR THANKSGIVING DAY, BETWEEN THE HOURS OF 4:00 P.M. TUESDAY TO 9:00 A.M. MONDAY.	
8. FOR CHRISTMAS, BETWEEN THE HOURS OF 4:00 P.M. THE FRIDAY BEFORE THE WEEK OF CHRISTMAS DAY AND 9:00 A.M. THE FOLLOWING TUESDAY AFTER THE WEEK OF CHRISTMAS.	

C) DO NOT CONDUCT ANY HAULING OPERATIONS AGAINST THE FLOW OF TRAFFIC OF AN OPEN TRAVELWAY UNLESS THE HAULING OPERATION IS PROTECTED BY BARRIER OR GUARDRAIL OR AS DIRECTED BY THE ENGINEER.

LANE AND SHOULDER CLOSURE REQUIREMENTS

D) REMOVE LANE CLOSURE DEVICES FROM THE LANE WHEN WORK IS NOT BEING PERFORMED BEHIND THE LANE CLOSURE OR WHEN A LANE CLOSURE IS NO LONGER NEEDED OR AS DIRECTED BY THE ENGINEER.

E) WHEN PERSONNEL AND/OR EQUIPMENT ARE WORKING WITHIN 15 FT OF AN OPEN TRAVEL LANE, CLOSE THE NEAREST OPEN SHOULDER USING ROADWAY STANDARD DRAWING NO. 1101.04 UNLESS THE WORK AREA IS PROTECTED BY BARRIER OR GUARDRAIL OR A LANE CLOSURE IS INSTALLED.

F) WHEN PERSONNEL AND/OR EQUIPMENT ARE WORKING ON THE SHOULDER ADJACENT TO AN UNDIVIDED FACILITY AND WITHIN 5 FT OF AN OPEN TRAVEL LANE, CLOSE THE NEAREST OPEN TRAVEL LANE USING ROADWAY STANDARD DRAWING NO. 1101.02 UNLESS THE WORK AREA IS PROTECTED BY BARRIER OR GUARDRAIL.

WHEN PERSONNEL AND/OR EQUIPMENT ARE WORKING ON THE SHOULDER ADJACENT TO A DIVIDED FACILITY AND WITHIN 10 FT OF AN OPEN TRAVEL LANE, CLOSE THE NEAREST OPEN TRAVEL LANE USING ROADWAY STANDARD DRAWING NO. 1101.02 UNLESS THE WORK AREA IS PROTECTED BY BARRIER OR GUARDRAIL.

G) WHEN PERSONNEL AND/OR EQUIPMENT ARE WORKING WITHIN A LANE OF TRAVEL OF AN UNDIVIDED OR DIVIDED FACILITY, CLOSE THE LANE ACCORDING TO THE TRAFFIC CONTROL PLANS, ROADWAY STANDARD DRAWINGS, OR AS DIRECTED BY THE ENGINEER. CONDUCT THE WORK SO THAT ALL PERSONNEL AND/OR EQUIPMENT REMAIN WITHIN THE CLOSED TRAVEL LANE.

H) DO NOT WORK SIMULTANEOUSLY WITHIN 15 FT ON BOTH SIDES OF AN OPEN TRAVELWAY, RAMP, OR LOOP WITHIN THE SAME LOCATION UNLESS PROTECTED WITH GUARDRAIL OR BARRIER.

PAVEMENT EDGE DROP OFF REQUIREMENTS

I) BACKFILL AT A 6:1 SLOPE UP TO THE EDGE AND ELEVATION OF EXISTING PAVEMENT IN AREAS ADJACENT TO AN OPENED TRAVEL LANE THAT HAS AN EDGE OF PAVEMENT DROP-OFF AS FOLLOWS:

BACKFILL DROP-OFFS THAT EXCEED 2 INCHES ON ROADWAYS WITH POSTED SPEED LIMITS OF 45 MPH OR GREATER.

BACKFILL DROP-OFFS THAT EXCEED 3 INCHES ON ROADWAYS WITH POSTED SPEED LIMITS LESS THAN 45 MPH.

BACKFILL WITH SUITABLE COMPACTED MATERIAL, AS APPROVED BY THE ENGINEER, AT NO EXPENSE TO THE DEPARTMENT.

J) DO NOT EXCEED A DIFFERENCE OF 2 INCHES IN ELEVATION BETWEEN OPEN LANES OF TRAFFIC FOR NOMINAL LIFTS OF 1.5 INCHES. INSTALL ADVANCE WARNING "UNEVEN LANES" SIGNS (W8-11) 500 FT IN ADVANCE AND A MINIMUM OF EVERY HALF MILE THROUGHOUT THE UNEVEN AREA.

TRAFFIC PATTERN ALTERATIONS

K) NOTIFY THE ENGINEER THIRTY (30) CALENDAR DAYS PRIOR TO ANY TRAFFIC PATTERN ALTERATION.

SIGNING

L) INSTALL ADVANCE WORK ZONE WARNING SIGNS WHEN WORK IS WITHIN 40 FT FROM THE EDGE OF TRAVEL LANE AND NO MORE THAN THREE (3) DAYS PRIOR TO THE BEGINNING OF CONSTRUCTION.

M) PROVIDE SIGNING AND DEVICES REQUIRED FOR THE TRUCK OFF-SITE DETOUR ROUTE AS SHOWN IN THE TRAFFIC CONTROL PLANS.

N) ENSURE ALL NECESSARY SIGNING IS IN PLACE PRIOR TO ALTERING ANY TRAFFIC PATTERN.

O) INSTALL BLACK ON ORANGE "DIP" SIGNS (W8-2) AND/OR "BUMP" SIGNS (W8-1) 500' IN ADVANCE OF THE UNEVEN AREA, OR AS DIRECTED BY THE ENGINEER.

TRAFFIC CONTROL DEVICES

P) WHEN LANE CLOSURES ARE NOT IN EFFECT SPACE CHANNELIZING DEVICES IN WORK AREAS NO GREATER IN FEET THAN TWICE THE POSTED SPEED LIMIT (MPH) EXCEPT, 10 FT ON-CENTER IN RADII, AND 3 FT OFF THE EDGE OF AN OPEN TRAVELWAY. REFER TO STANDARD SPECIFICATIONS FOR ROADS AND STRUCTURES SECTIONS 1130 (DRUMS), 1135 (CONES) AND 1180 (SKINNY DRUMS) FOR ADDITIONAL REQUIREMENTS.

PAVEMENT MARKINGS AND MARKERS

Q) INSTALL TEMPORARY PAVEMENT MARKINGS AND TEMPORARY PAVEMENT MARKERS ON INTERIM LAYERS OF PAVEMENT AS FOLLOWS:

ROAD NAME	MARKING	MARKER
-L- NC 54 (S. MIAMI BLVD)	PAINT	N/A
-Y1- SR 1978 (HOPSON ROAD)	PAINT	N/A

R) PLACE ONE APPLICATION OF PAINT FOR TEMPORARY TRAFFIC PATTERNS. PLACE A SECOND APPLICATION OF PAINT SIX (6) MONTHS AFTER THE INITIAL APPLICATION AND EVERY SIX MONTHS AS DIRECTED BY THE ENGINEER.

S) TIE PROPOSED PAVEMENT MARKING LINES TO EXISTING PAVEMENT MARKING LINES.

T) REMOVE/REPLACE ANY CONFLICTING/DAMAGED PAVEMENT MARKINGS AND MARKERS BY THE END OF EACH DAY'S OPERATION.

U) TRACE THE EXISTING MONOLITHIC ISLAND LOCATIONS WITH PROPER COLOR PAVEMENT MARKINGS PRIOR TO REMOVAL PLACE DRUMS TO DELINEATE ANY EXISTING MONOLITHIC ISLANDS AFTER REMOVAL.

V) LAW ENFORCEMENT MAY BE USED TO MAINTAIN TRAFFIC THROUGH THE WORK AREA AND/OR INTERSECTIONS AS DIRECTED BY THE ENGINEER.

W) ALL CURB RAMP LOCATIONS SHALL BE DERIVED FROM STATIONING SHOWN ON PAVEMENT MARKING PLANS OR AS DIRECTED BY THE ENGINEER IN COORDINATION WITH THE SIGNING AND DELINEATION UNIT.

X) IN THE EVENT A TIE-IN CANNOT BE MADE IN ONE DAY'S TIME, BRING THE TIE-IN AREA TO AN APPROPRIATE ROADWAY ELEVATION AS DETERMINED BY THE ENGINEER. PLACE BLACK ON ORANGE "LOOSE GRAVEL" SIGNS (W8-7) AND BLACK ON ORANGE "PAVEMENT ENDS" SIGNS (W8-3) 350' AND 350' RESPECTIVELY IN ADVANCE OF THE UNEVEN AREAS. USE DRUMS TO DELINEATE THE EDGE OF ROADWAY ALONG UNPAVED AREAS.

2/14/2026 G:\vias\vias_infrastructure\Engineering - Documents\03 Projects\PRJ23008M-NC05_SM-6105H\04-Design\SM-6105H\Work Zone Traffic Control\SM-6105H_ITC_TMP01B.dgn User:MatthewDouglas



220 HORIZON DRIVE, SUITE 117
RALEIGH, NC 27615
PHONE (727) 214-7698
LICENSE NO. P-2673
WWW.VIASINFRASTRUCTURE.COM

APPROVED: _____
DATE: 2/14/2026

Signed by: *Matthew A. Douglas*
48426382172A4C2

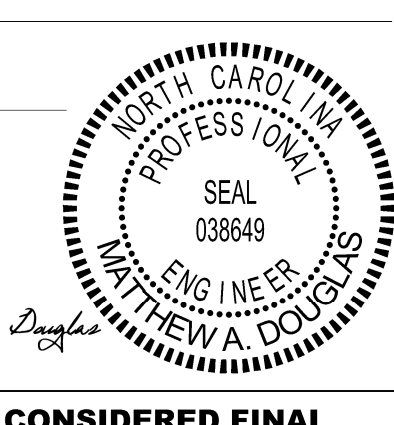

DOCUMENT NOT CONSIDERED FINAL UNLESS ALL SIGNATURES COMPLETED



TRANSPORTATION OPERATIONS PLAN

PHASING

PHASE I

- STEP 1 INSTALL WORK ZONE SIGNING ALONG ALL APPROACH ROADWAYS USING ROADWAY STANDARD DRAWING (RSD) 1101.01 SHEET 3 OF 3. INSTALL PEDESTRIAN DETOUR (SEE TMP-6) . PEDESTRIAN DETOUR WILL UTILIZE THE EAST SIDE OF NC 54 WITH CROSSINGS AT SLATER ROAD AND SOUTHERN SIDE OF HOPSON ROAD, BOTH OF WHICH CURRENTLY HAVE SIGNALIZED PEDESTRIAN CROSSINGS.
- STEP 2 USING TMP-2 INSTALL THE TRUCK OFF-SITE DETOUR TO REMAIN FOR ENTIRE DURATION OF PROJECT.
- STEP 3 ESTABLISH PRELIMINARY EROSION CONTROL MEASURES AND THEN CLEAR AND GRUB PROJECT LIMITS.

PHASE II

USING TEMPORARY LANE CLOSURES (RSD 1101.02 SHEET 3 OF 19) , TEMPORARY SIGNAL PHASE MODIFICATIONS, TIME RESTRICTIONS, AND TMP-3 THRU TMP-4, CONSTRUCT THE FOLLOWING:

- STEP 1 REMOVE MEDIAN CONCRETE ISLAND ALONG -Y1- (HOPSON RD) FROM -Y1- STA 43+00± TO -Y1- STA 43+67±. REPLACE WITH DRUMS AS SHOWN ON TMP-3.
- STEP 2 ONCE ISLAND REMOVAL IS COMPLETED, REMOVE EXISTING THRU/RIGHT MARKINGS ON -Y1- SR 1978 (HOPSON ROAD) AND REPLACE WITH TEMPORARY PAVEMENT MARKINGS. INCLUDE SIGN R3-7 "RIGHT LANE MUST TURN RIGHT", AS SHOWN ON TMP-3.
- STEP 3 REDUCE EXISTING LANE WIDTHS TO 11 FEET ON -L- (S MIAMI BLVD) AS SHOWN ON TMP-3.
- STEP 4 CONSTRUCT THE PROPOSED PAVEMENT REMOVAL AND ROAD RECONSTRUCTION ON ALL OF -Y1- AS SHOWN ON TMP-4, INCLUDING CURB AND GUTTER, DRAINAGE, CURB RAMP AND SIDEPATH.

PHASE III

- STEP 1 USING RSD 1101.04 (SHEET 1 OF 2), TEMPORARY SIGNAL PHASE MODIFICATIONS (AS SHOWN ON SIGNAL PLANS), AND TMP-5, AWAY FROM TRAFFIC CONSTRUCT THE PROPOSED WIDENING FROM -L- STA 11+34± TO -L- 15+30± INCLUDING CURB AND GUTTER, SIDEPATH, AND DRAINAGE. USE RSD 1101.02 (SHEET 3 OF 19) FOR ANY WIDENING DONE WITHIN 5 FT OF OPEN TRAVEL WAY.
- STEP 2 USING RSD 1101.02 (SHEET 3 OF 19) AND SHEET TMP-5, TEMPORARILY CLOSE LANE TO CONSTRUCT THE PROPOSED MILL AND FILL FROM -L- STA 11+34± TO -L- STA 15+30±.
- STEP 3 USING RSD 1101.02 (SHEET 3 OF 19) AND TEMPORARY SIGNAL, INSTALL NEW ISLAND ON -Y1-.

PHASE IV

- STEP 1 INSTALL FINAL LIFT OF SURFACE COURSE AND FINAL PAVEMENT MARKINGS, INCLUDING RE-STRIPING -Y1- SR 1978 (HOPSON ROAD) RIGHT TURN LANE BACK TO A THRU-RIGHT MOVEMENT, EXISTING THRU-RIGHT MOVEMENT FROM -L- (NC 54) TO THRU ONLY AND CROSSWALKS. REVISE SIGNAL PHASES TO FINAL MODIFICATIONS.
- STEP 2 REMOVE ALL WORK ZONE TRAFFIC CONTROL DEVICES.

12/17/2025 C:\Vias\VIAS Infrastructure\Engineering - Documents\03 Projects\PRJ23008M-NC05_SM-6105H\04-Design\SM-6105H\Work Zone Traffic Control\SM-6105H_TTC_TMP01B.dgn User:MatthewDouglas



220 HORIZON DRIVE, SUITE 117
RALEIGH, NC 27615
PHONE (727) 214-7698
LICENSE NO. P-2673
WWW.VIASINFRASTRUCTURE.COM

APPROVED: _____
DATE: 12/17/2025

Signed by: *Matthew A. Douglas*
48426382172AAC2

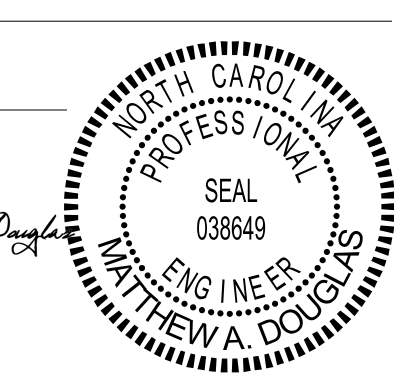

**DOCUMENT NOT CONSIDERED FINAL
UNLESS ALL SIGNATURES COMPLETED**

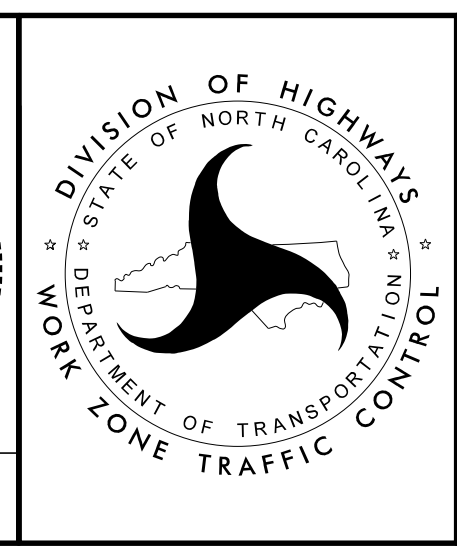

**TRANSPORTATION
OPERATIONS
PLAN**

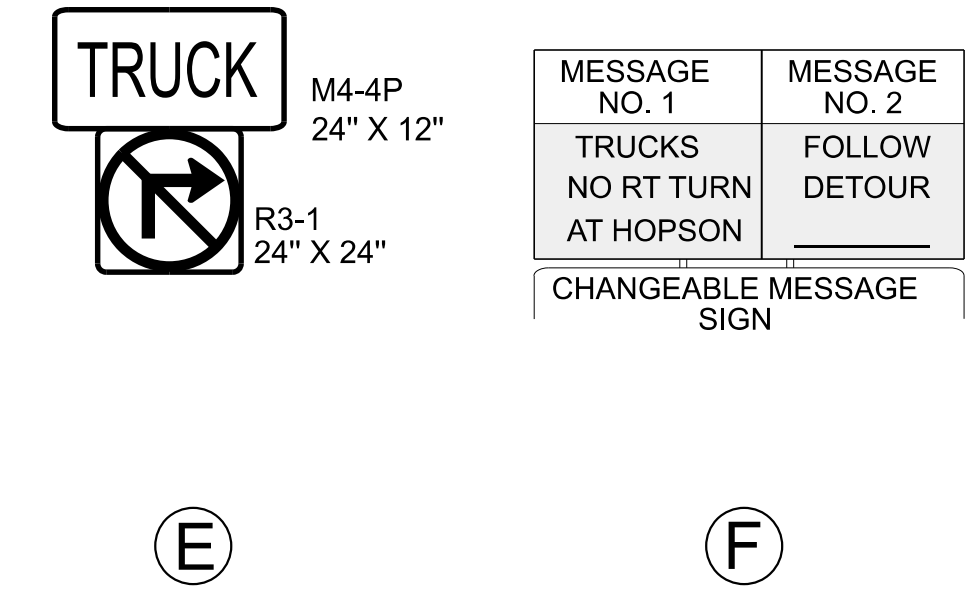
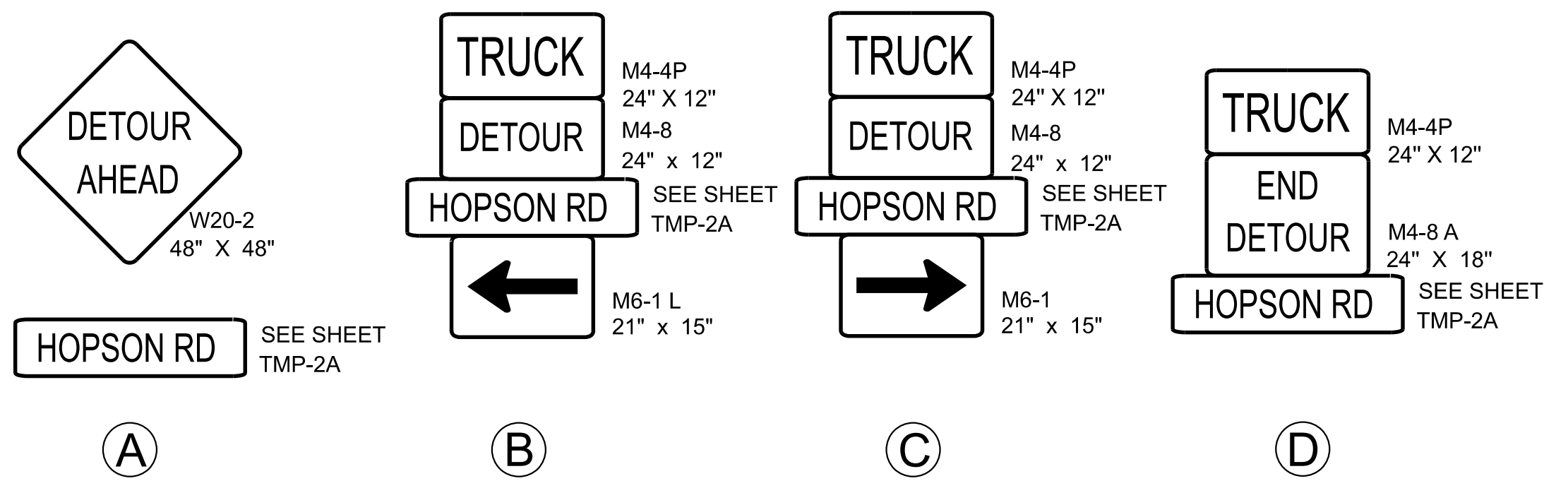
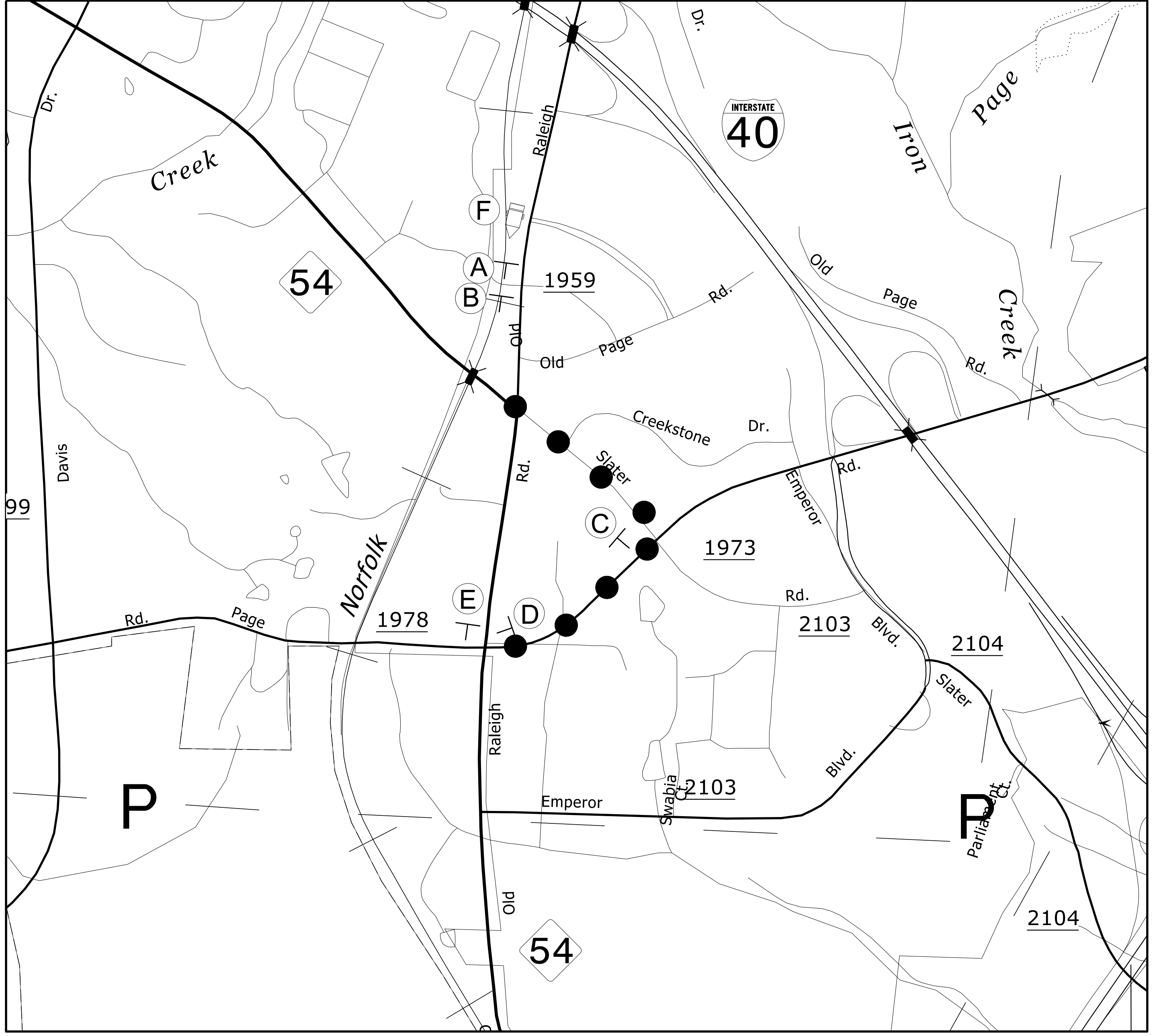

12/17/2025
 C:\Vias\VIAS Infrastructure\Engineering - Documents\03 Projects\PRJ23008M-NC05-SM-6105H\04-Design\SM-6105H\Work Zone Traffic Control\SM-6105H_ITC_TMP02.dgn
 User:MatthewDouglas

 220 HORIZON DRIVE, SUITE 117 RALEIGH, NC 27615 PHONE (727) 214-7698 LICENSE NO. P-2673 WWW.VIASINFRASTRUCTURE.COM	APPROVED: _____ DATE: 12/17/2025			OFF-SITE TRUCK DETOUR
	Signed by: <i>Matthew A. Douglas</i> 484283B217244C2			

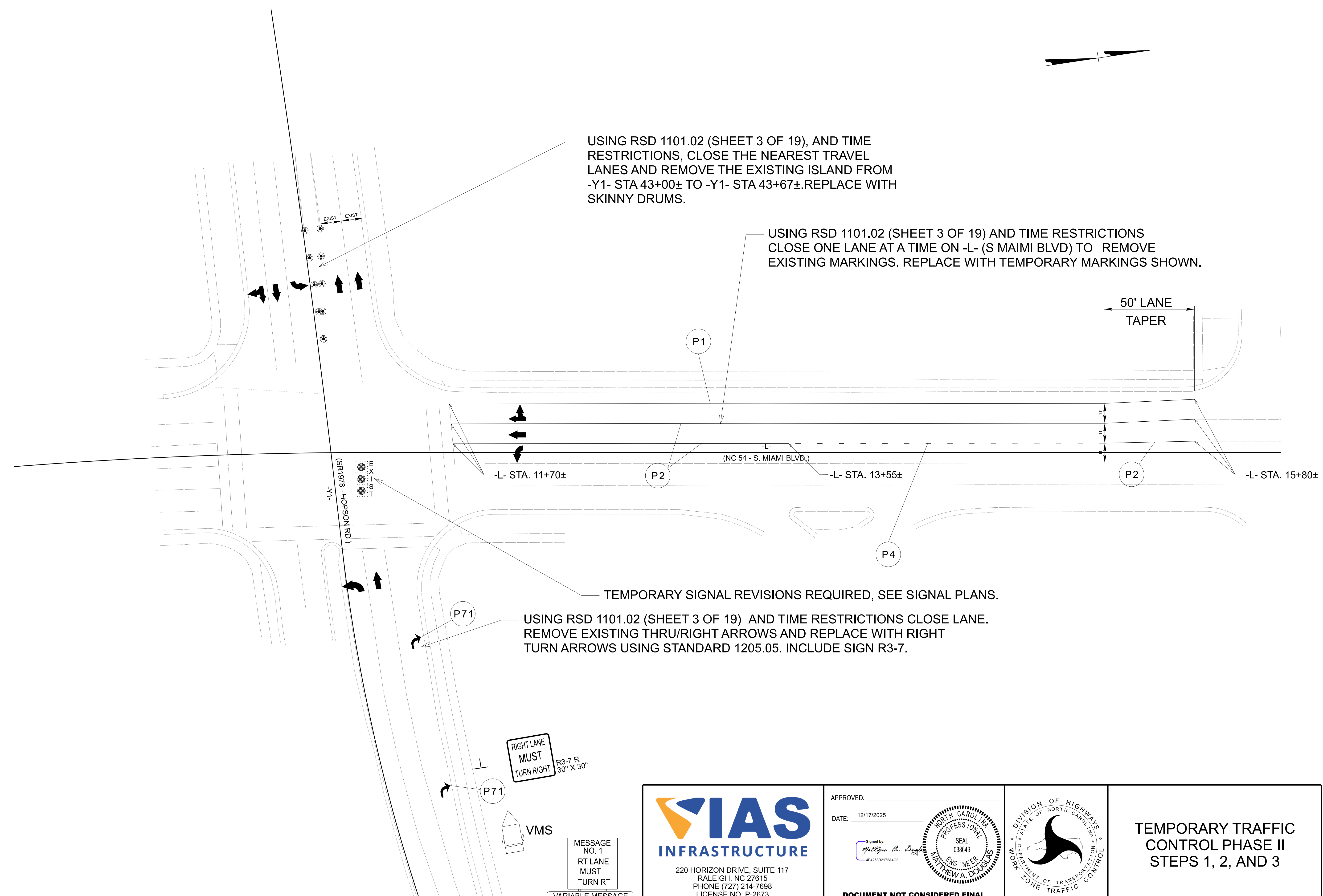
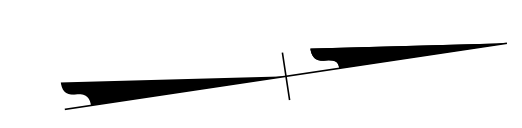

USING RSD 1101.02 (SHEET 3 OF 19), AND TIME RESTRICTIONS, CLOSE THE NEAREST TRAVEL LANES AND REMOVE THE EXISTING ISLAND FROM -Y1- STA 43+00± TO -Y1- STA 43+67±. REPLACE WITH SKINNY DRUMS.

USING RSD 1101.02 (SHEET 3 OF 19) AND TIME RESTRICTIONS CLOSE ONE LANE AT A TIME ON -L- (S MAIMI BLVD) TO REMOVE EXISTING MARKINGS. REPLACE WITH TEMPORARY MARKINGS SHOWN.

TEMPORARY SIGNAL REVISIONS REQUIRED, SEE SIGNAL PLANS.

USING RSD 1101.02 (SHEET 3 OF 19) AND TIME RESTRICTIONS CLOSE LANE. REMOVE EXISTING THRU/RIGHT ARROWS AND REPLACE WITH RIGHT TURN ARROWS USING STANDARD 1205.05. INCLUDE SIGN R3-7.

RIGHT LANE MUST TURN RIGHT R3-7 R 30" X 30"

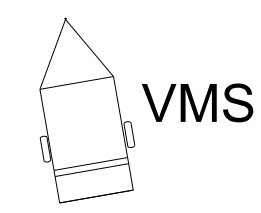

MESSAGE NO. 1
RT LANE MUST TURN RT
VARIABLE MESSAGE SIGN

<p>220 HORIZON DRIVE, SUITE 117 RALEIGH, NC 27615 PHONE (727) 214-7698 LICENSE NO. P-2673 WWW.VIASINFRASTRUCTURE.COM</p>	<p>APPROVED: _____</p> <p>DATE: 12/17/2025</p> <p>Signed by: <i>Matthew A. Douglas</i> 484263821724402</p>		<p>TEMPORARY TRAFFIC CONTROL PHASE II STEPS 1, 2, AND 3</p>
	<p>DOCUMENT NOT CONSIDERED FINAL UNLESS ALL SIGNATURES COMPLETED</p>		

12/17/2025
 C:\Vias\VIAS Infrastructure\Engineering - Documents\03 Projects\PRJ23008M-NC05_SM-6105H\04-Design\SM-6105H\Work Zone Traffic Control\SM-6105H_TTC_TMP03.dgn
 User: Matthew Douglas

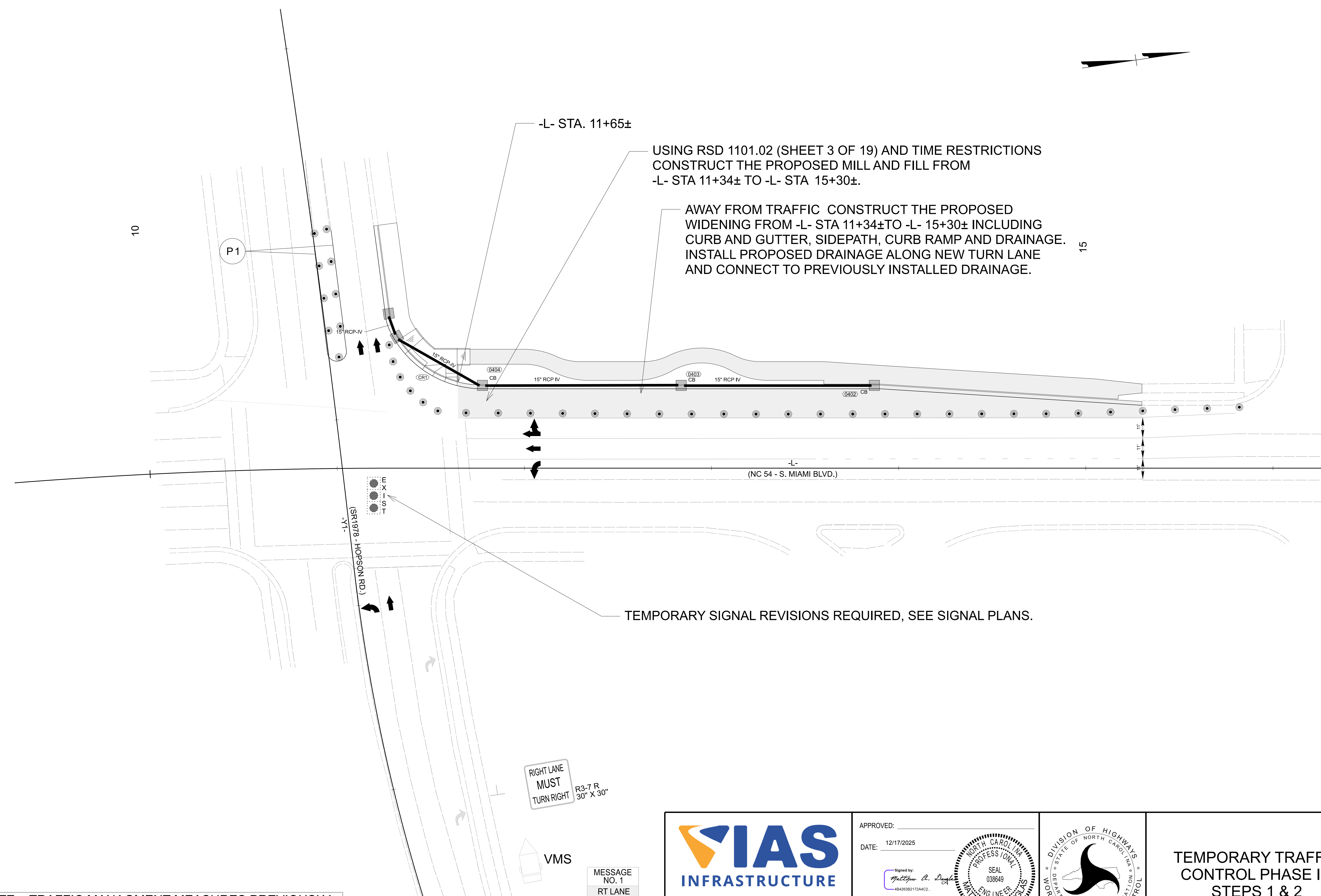

USING RSD 1101.02 (SHEET 3 OF 19) AND TIME RESTRICTIONS
CONSTRUCT THE PROPOSED MILL AND FILL FROM
-L- STA 11+34± TO -L- STA 15+30±.

AWAY FROM TRAFFIC CONSTRUCT THE PROPOSED
WIDENING FROM -L- STA 11+34± TO -L- 15+30± INCLUDING
CURB AND GUTTER, SIDEPATH, CURB RAMP AND DRAINAGE.
INSTALL PROPOSED DRAINAGE ALONG NEW TURN LANE
AND CONNECT TO PREVIOUSLY INSTALLED DRAINAGE.

TEMPORARY SIGNAL REVISIONS REQUIRED, SEE SIGNAL PLANS.

NOTE: TRAFFIC MANAGEMENT MEASURES PREVIOUSLY
INSTALLED AND TO BE MAINTAINED ARE SHOWN
SHADED BACK.

RIGHT LANE
MUST
TURN RIGHT
R3-7 R
30" X 30"

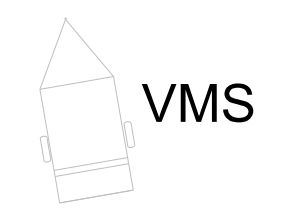

MESSAGE
NO. 1
RT LANE
MUST
TURN RT
VARIABLE MESSAGE
SIGN

VIAS
INFRASTRUCTURE

220 HORIZON DRIVE, SUITE 117
RALEIGH, NC 27615
PHONE (727) 214-7698
LICENSE NO. P-2673
WWW.VIASINFRASTRUCTURE.COM

APPROVED: _____
DATE: 12/17/2025

Signed by: *Matthew A. Douglas*
484263821724AC2

SEAL
038649
NORTH CAROLINA
PROFESSIONAL
ENGINEER
MATTHEW A. DOUGLAS

**DOCUMENT NOT CONSIDERED FINAL
UNLESS ALL SIGNATURES COMPLETED**

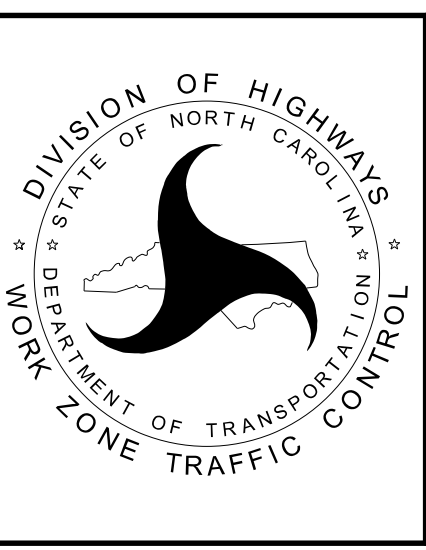

**TEMPORARY TRAFFIC
CONTROL PHASE III,
STEPS 1 & 2**

12/17/2025
C:\Vias\VIAS Infrastructure\Engineering - Documents\03 Projects\PRJ23008M-NC05_SM-6105H\04-Design\SM-6105H\Work Zone Traffic Control\SM-6105H_ITC_TMP05.dgn
User: Matthew Douglas

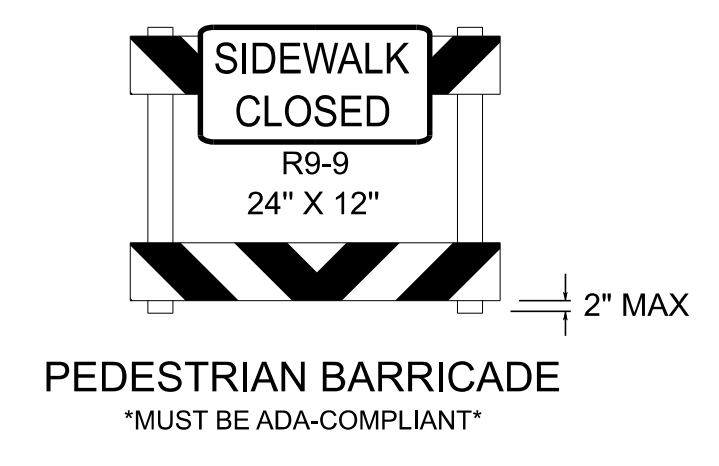
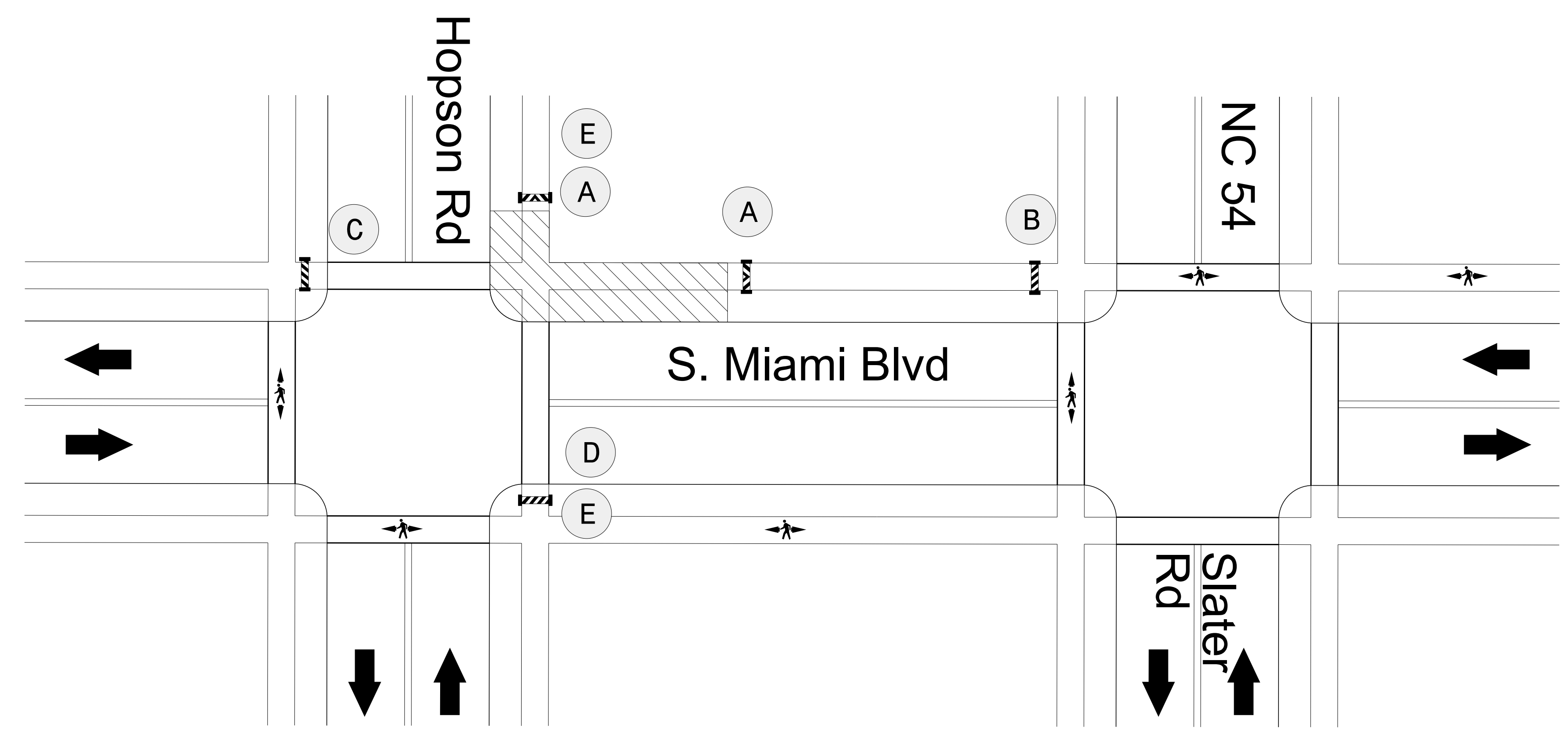

A

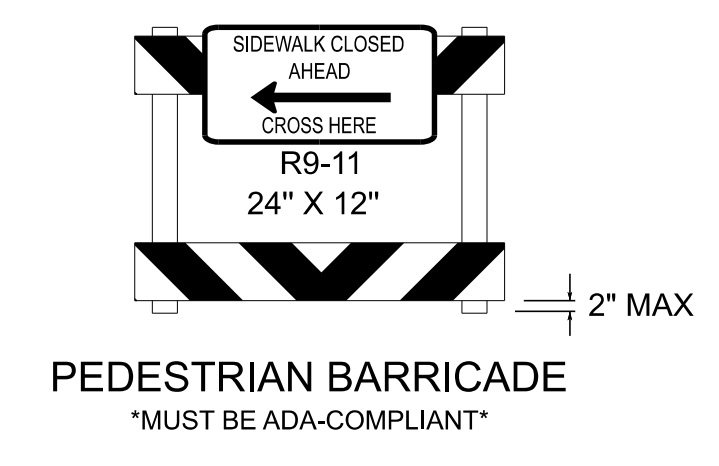

B

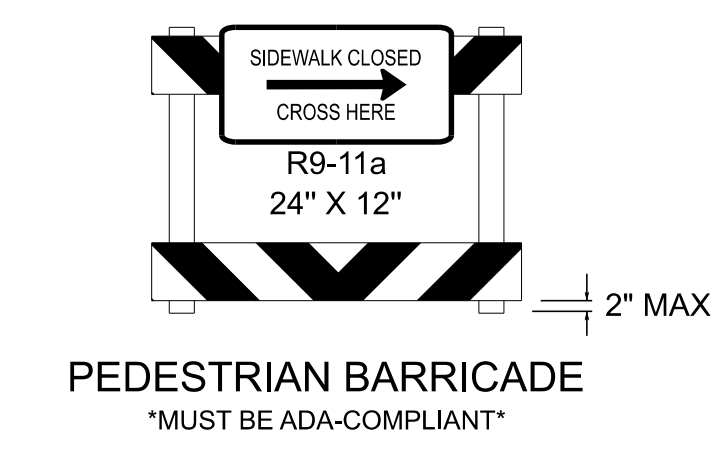

C

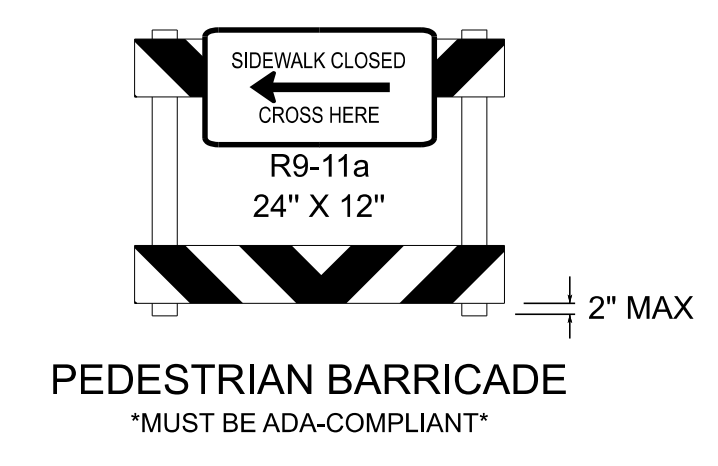

D

E NOTE: CONTRACTOR TO INCLUDE PEDESTRIAN TRANSPORT SERVICE QR CODE FOR PEDESTRIANS TO RECIEVE RIDES TRAVELING WEST THROUGH HOPSON SIDEWALK CLOSURE.

12/17/2025
 C:\Vias\VIAS Infrastructure\Engineering - Documents\03 Projects\PRJ23008M-NC05_SM-6105H\04-Design\SM-6105H\Work Zone Traffic Control\SM-6105H_ITC_TMP06.dgn
 User:MatthewDouglas

 220 HORIZON DRIVE, SUITE 117 RALEIGH, NC 27615 PHONE (727) 214-7698 LICENSE NO. P-2673 WWW.VIASINFRASTRUCTURE.COM	APPROVED: _____ DATE: 12/17/2025 Signed by: <i>Matthew A. Douglas</i> 48426382172AAC2			TEMPORARY TRAFFIC CONTROL PEDESTRIAN DETOUR
	DOCUMENT NOT CONSIDERED FINAL UNLESS ALL SIGNATURES COMPLETED			

DEPARTMENT OF TRANSPORTATION

SIGNING AND PAVEMENT MARKING PLAN
WAKE COUNTY

LOCATION: NC-98 (DURHAM RD.) AT SR-1005 (SIX FORKS RD.)

SM-5705AG

PMP-1

NORTH CAROLINA
DEPARTMENT OF TRANSPORTATION
WAKE COUNTY



ROADWAY DESIGN UNIT
ROADWAY DESIGN
ENGINEER

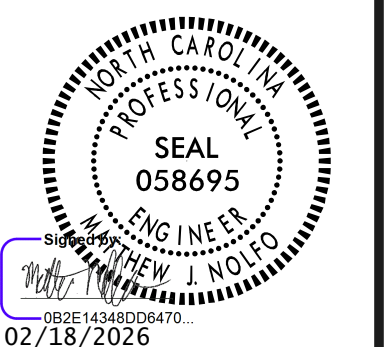

DOCUMENT NOT CONSIDERED FINAL
UNLESS ALL SIGNATURES COMPLETED
PREPARED BY L.C.

INDEX

SHEET NO.	DESCRIPTION
PMP-1	PAVEMENT MARKING PLAN COVER SHEET, SCHEDULE, NOTES, AND STANDARD DRAWINGS
PMP-2	PAVEMENT MARKING PLANS
PMP-3	TYPE D SIGN

ROADWAY STANDARD DRAWINGS

THE FOLLOWING ROADWAY STANDARDS AS APPEAR IN "ROADWAY STANDARD DRAWINGS" - N.C. DEPARTMENT OF TRANSPORTATION - RALEIGH, N.C., DATED JANUARY 2024 ARE APPLICABLE TO THIS PROJECT AND BY REFERENCE HEREBY ARE CONSIDERED A PART OF THESE PLANS:

STD. NO.	TITLE
1205.01	PAVEMENT MARKINGS - LINE TYPES & OFFSETS
1205.02	PAVEMENT MARKINGS - 2 LANE & MULTILANE ROADWAYS
1205.04	PAVEMENT MARKINGS - INTERSECTIONS
1205.05	PAVEMENT MARKINGS - TURN LANES
1205.08	PAVEMENT MARKINGS - SYMBOLS & WORD MESSAGES
1250.01	RAISED PAVEMENT MARKERS - INSTALLATION SPACING
1251.01	RAISED PAVEMENT MARKERS - (PERMANENT AND TEMPORARY)

**GENERAL NOTES
SIGNING**

- SIGNS FURNISHED BY CONTRACTOR
- ALL TYPE 'D' AND 'F' SIGNS SHALL BE MOUNTED ON TWO U-CHANNEL POSTS UNLESS OTHERWISE INDICATED ON THE PLANS
- WHEN NOT STATIONED OR DIMENSIONED ON PLANS, ALL 'E' AND 'F' SIGNS SHALL BE FIELD LOCATED BY THE ENGINEER
- ALL EXISTING SIGNS ON "U" CHANNEL POSTS WITHIN THE PROJECT LIMITS SHALL BE REMOVED AND DISPOSED OF UNLESS OTHERWISE NOTED ON PLANS
- WHEN EXISTING SIGNS ARE REMOVED AND INSTALLED ON NEW SUPPORTS, THE RE-ERECTION SHALL IMMEDIATELY FOLLOW THE REMOVAL
- THE BACKGROUND FOR TYPE E AND F SIGNS SHALL BE TYPE C REFLECTIVE SHEETING

PAVEMENT MARKING SCHEDULE

SYMBOL	DESCRIPTION
THERMOPLASTIC(4", 90 MILS)	
T1	WHITE EDGELINE
T2	WHITE SOLID LANE LINE
T4	3 FT. - 9 FT./SP WHITE MINISKIP
T13	YELLOW DOUBLE CENTER
THERMOPLASTIC(24", 90 MILS)	
T61	WHITE STOPBAR
THERMOPLASTIC PAVEMENT MARKING SYMBOLS (90 MILS)	
T70	LEFT TURN ARROW
T71	RIGHT TURN ARROW
T72	STRAIGHT ARROW
MARKERS	
SNOWPLOWABLE PAVEMENT MARKERS	
MF	CRYSTAL & RED
ME	YELLOW & YELLOW

**GENERAL NOTES
PAVEMENT MARKING**

- THE FOLLOWING GENERAL NOTES APPLY AT ALL TIMES FOR THE DURATION OF THE CONSTRUCTION PROJECT, EXCEPT WHEN OTHERWISE NOTED IN THE PLAN, OR DIRECTED BY THE ENGINEER.
- A) INSTALL PAVEMENT MARKINGS AND PAVEMENT MARKERS ON THE FINAL SURFACE AS FOLLOWS:

ROAD NAME	MARKING	MARKER
ALL ROADS	THERMOPLASTIC	SNOWPLOWABLE
 - B) TIE PROPOSED PAVEMENT MARKING LINES TO EXISTING PAVEMENT MARKING LINES.
 - C) REMOVE/REPLACE ANY CONFLICTING/DAMAGED PAVEMENT MARKINGS AND MARKERS.
 - D) UNLESS OTHERWISE SPECIFIED, HEATED-IN-PLACE THERMOPLASTIC MAY BE USED IN LIEU OF EXTRUDED THERMOPLASTIC FOR STOP BARS, SYMBOLS, CHARACTERS AND DIAGONALS. IF HEATED-IN-PLACE IS USED, IT SHALL BE PAID FOR USING THE EXTRUDED THERMOPLASTIC PAY ITEM.
 - E) REFER TO THE TRAFFIC SIGNAL DESIGN PLANS FOR STOP BAR INFORMATION.

**SUMMARY OF
SIGNING QUANTITIES**

ITEM NO.	DESC. NO.	SECT. NO.	QUANTITY	UNIT
4025000000	901	CONTRACTOR FURNISHED, TYPE D SIGN.....	15	SF
4025000000	901	CONTRACTOR FURNISHED, TYPE F SIGN.....	16.5	SF
4072000000	903	SUPPORTS, 3 LB STEEL U -CHANNEL.....	90	LF
4080200000	903	SUPPORTS, STEEL SQUARE TUBE.....	15	LF
4096000000	904	SIGN ERECTION, TYPE D.....	1	EA
4108000000	904	SIGN ERECTION, TYPE F.....	1	EA
4116100000	904	SIGN ERECTION, RELOCATE TYPE D & E (GROUND MOUNTED).....	5	EA
4155000000	907	DISPOSAL OF SIGN SYSTEM, U-CHANNEL.....	2	EA
4192000000	907	DISPOSAL OF SUPPORT, U-CHANNEL.....	3	EA

**SIGNING PAY
ITEM NOTES**

- DISPOSAL OF SUPPORT, U-CHANNEL
- DISPOSAL OF SIGN SYSTEM, U-CHANNEL
- RETAIN SIGN SYSTEM
- SIGN ERECTION, RELOCATE TYPE D & E (GROUND MOUNTED)

MATTHEW NOLFO, PE
PROJECT ENGINEER

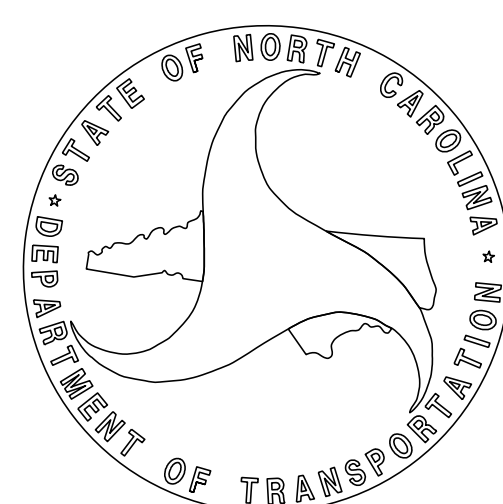

SUNIL PATEL
PROJECT DESIGN ENGINEER

REVISIONS

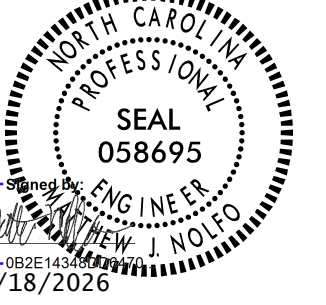

BEGIN TIP PROJECT
SM-5705AG
-EL- STA. 12 + 82.42

END TIP PROJECT
SM-5705AG
-EL- STA. 21 + 27.64

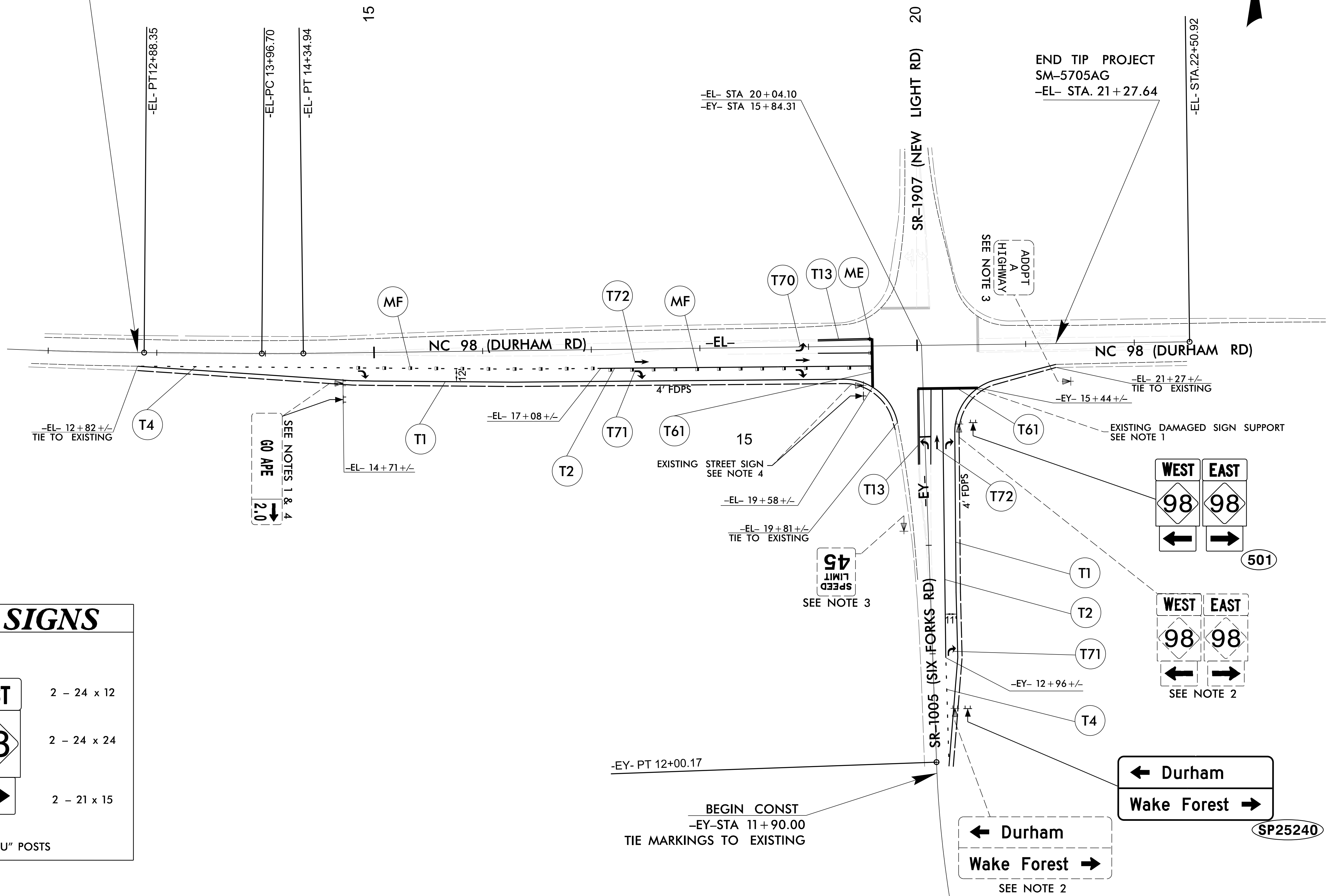

TYPE "F" SIGNS

(501)	WEST EAST	2 - 24 x 12
	98 98	2 - 24 x 24
	← →	2 - 21 x 15

MOUNTED ON TWO "U" POSTS

← Durham

Wake Forest →

(SP25240)

← Durham

Wake Forest →

SEE NOTE 2

REVISIONS

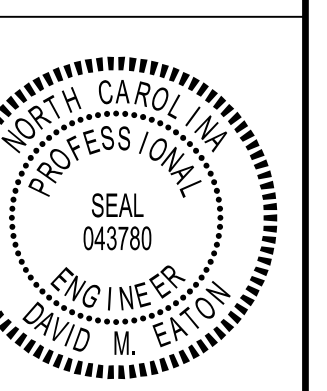

INCOMPLETE PLANS
DO NOT USE FOR CONSTRUCTION
DOCUMENT NOT CONSIDERED FINAL
UNLESS ALL SIGNATURES COMPLETED

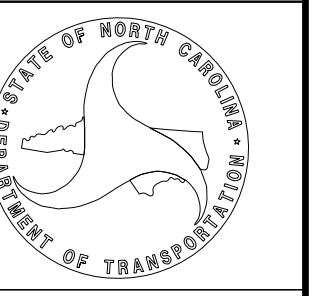

SIGN NUMBER: SP25240
TYPE: D
QUANTITY: 1
SIGN WIDTH: 6'-0"
HEIGHT: 2'-6"
TOTAL AREA: 15 Sq.Ft.
BORDER TYPE: FLUSH
RECESS: 0"
WIDTH: 0-3/4"
RADII: 3"
NO. Z BARS:
LENGTH:

BACKG COLOR: Green / Green
COPY COLOR: White

SYMBOL	X	Y	WID	HT
AR_Type D	5.8	19.3	6	9
AR_Type D	57.2	4.7	6	9

MAT'L: 0.125" (3.2 mm) ALUMINUM

DESIGN BY: A.SCOTT
PROJECT ID: SM-5705AG
CHECKED BY: M.EATON
LOCATION: NC 98 (DURHAM RD.) AT SR 1005 (SIX FORKS RD.)
Jul 14, 2025
DIV: 5

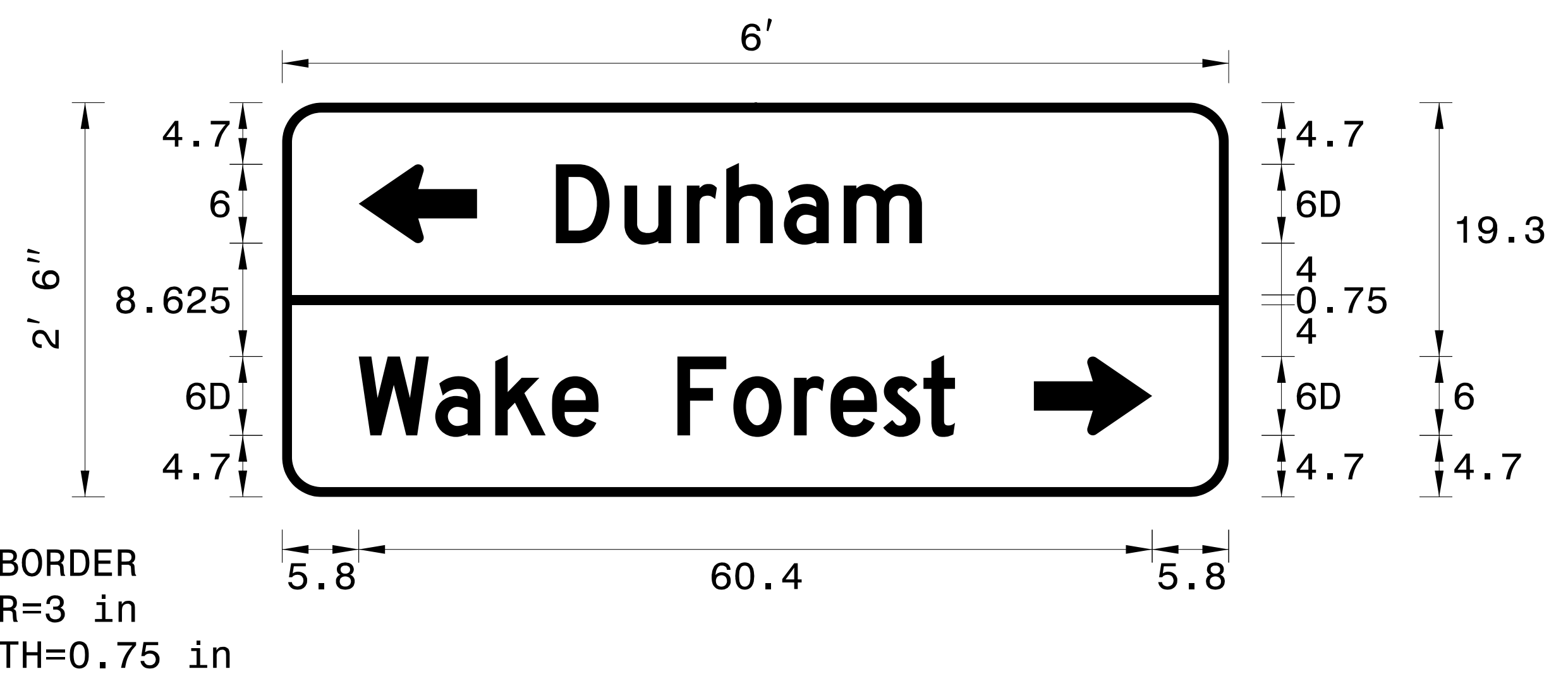

USE NOTES:

1. Legend and border(except those that are colored black) shall be direct applied Grade C sheeting.
2. Background shall be Grade C reflective sheeting.

Spacing Factor is 1 unless specified otherwise

LETTER POSITIONS

Letter spacings are to start of next letter														Series/Size Text Length	
	D	u	r	h	a	m									D 2000 27.8
20.8	5.2	4.75	3	4.375	4.6	6	23.3								
	W	a	k	e		F	o	r	e	s	t				D 2000 45.4
5.8	5.8	4.6	4.3	3.5	6	4.25	4.625	2.8	4	3.1	2.4	20.8			

3/2/2026
C:\Users\VIAS\Infrastructure\Engineering - Documents\03 Projects\PRJ23008M-NCD5_Siv-6105H\04-Design\SM-6105H\Signing and Delineation\Pavement Marking\Design\SM-6105H_TTC_PMP_01.dgn
User: Matthew Douglas

CONTRACT: DE00419 T.I.P.: SM-6105H / HS-2405AH

STATE OF NORTH CAROLINA
DEPARTMENT OF TRANSPORTATION

PAVEMENT MARKING PLAN
DURHAM COUNTY

TIP NO.	SHEET NO.
SM-6105H / HS-2405AH	PMP-1
APPROVED: _____	
DATE: _____	
SEAL 3/2/2026	
	
<p>Signed by: <i>Matthew A. Douglas</i> 48426382172442</p>	
DOCUMENT NOT CONSIDERED FINAL UNLESS ALL SIGNATURES COMPLETED	

INDEX	
SHEET NO.	DESCRIPTION
PMP-1	PAVEMENT MARKING PLAN TITLE SHEET
PMP-1B	DETAIL OF RAISED PAVEMENT MARKERS
PMP-2	PAVEMENT MARKING DETAIL

ROADWAY STANDARD DRAWING	
STD. NO.	TITLE
1205.01	PAVEMENT MARKINGS - LINE TYPES AND OFFSETS
1205.02	PAVEMENT MARKINGS - TWO-LANE AND MULTILANE ROADWAYS
1205.04	PAVEMENT MARKINGS - INTERSECTIONS
1205.05	PAVEMENT MARKINGS - TURN LANES
1205.07	PAVEMENT MARKINGS - PEDESTRIAN CROSSWALKS
1205.08	PAVEMENT MARKINGS - SYMBOLS AND WORD MESSAGES
1205.09	PAVEMENT MARKINGS - PAINTED ISLANDS
1250.01	RAISED PAVEMENT MARKERS - INSTALLATION SPACING
1251.01	RAISED PAVEMENT MARKERS - PERMANENT AND TEMPORARY

GENERAL NOTES		
THE FOLLOWING GENERAL NOTES APPLY AT ALL TIMES FOR THE DURATION OF THE CONSTRUCTION PROJECT, EXCEPT WHEN OTHERWISE NOTED IN THE PLAN, OR DIRECTED BY THE ENGINEER.		
A) INSTALL PAVEMENT MARKINGS AND PAVEMENT MARKERS ON THE FINAL SURFACE AS FOLLOWS:		
ROAD NAME	MARKING	MARKER
NC 54 (S. MIAMI BLVD.) -L-	THERMOPLASTIC	SNOWPLOWABLE
SR 1978 (HOPSON RD.) -Y1-	THERMOPLASTIC	SNOWPLOWABLE
D) TIE PROPOSED PAVEMENT MARKING LINES TO EXISTING PAVEMENT MARKING LINES.		
E) REMOVE/REPLACE ANY CONFLICTING/DAMAGED PAVEMENT MARKINGS AND MARKERS.		
F) UNLESS OTHERWISE SPECIFIED, HEATED-IN-PLACE THERMOPLASTIC MAY BE USED IN LIEU OF EXTRUDED THERMOPLASTIC FOR STOP BARS, SYMBOLS, CHARACTERS AND DIAGONALS. IF HEATED-IN-PLACE IS USED, IT SHALL BE PAID FOR USING THE EXTRUDED THERMOPLASTIC PAY ITEM.		
G) USE NO TRACK MARKINGS FOR CROSSWALKS AS SHOWN IN ROADWAY STANDARD DRAWING 1205.07 (SHEET 2 OF 2)		

PLAN SUBMITTED TO: N.C.D.O.T. SIGNING AND DELINEATION UNIT	
MITCH EATON, PE	SIGNING & DELINEATION REGIONAL ENGINEER
DERRICK H. BEARD	SIGNING & DELINEATION PROJECT DESIGN ENGINEER

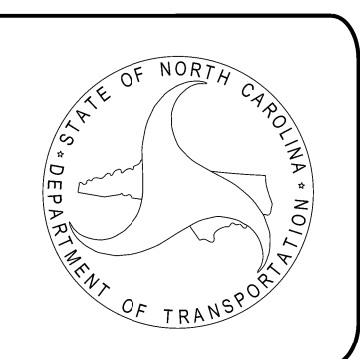

PLAN PREPARED BY: VIAS INFRASTRUCTURE	
NICK RAMIREZ, PE	PROJECT MANAGER
MATTHEW DOUGLAS, PE	PROJECT DESIGN ENGINEER



220 HORIZON DRIVE, SUITE 117
RALEIGH, NC 27615
PHONE (727) 214-7698
LICENSE NO. P-2673
WWW.VIASINFRASTRUCTURE.COM

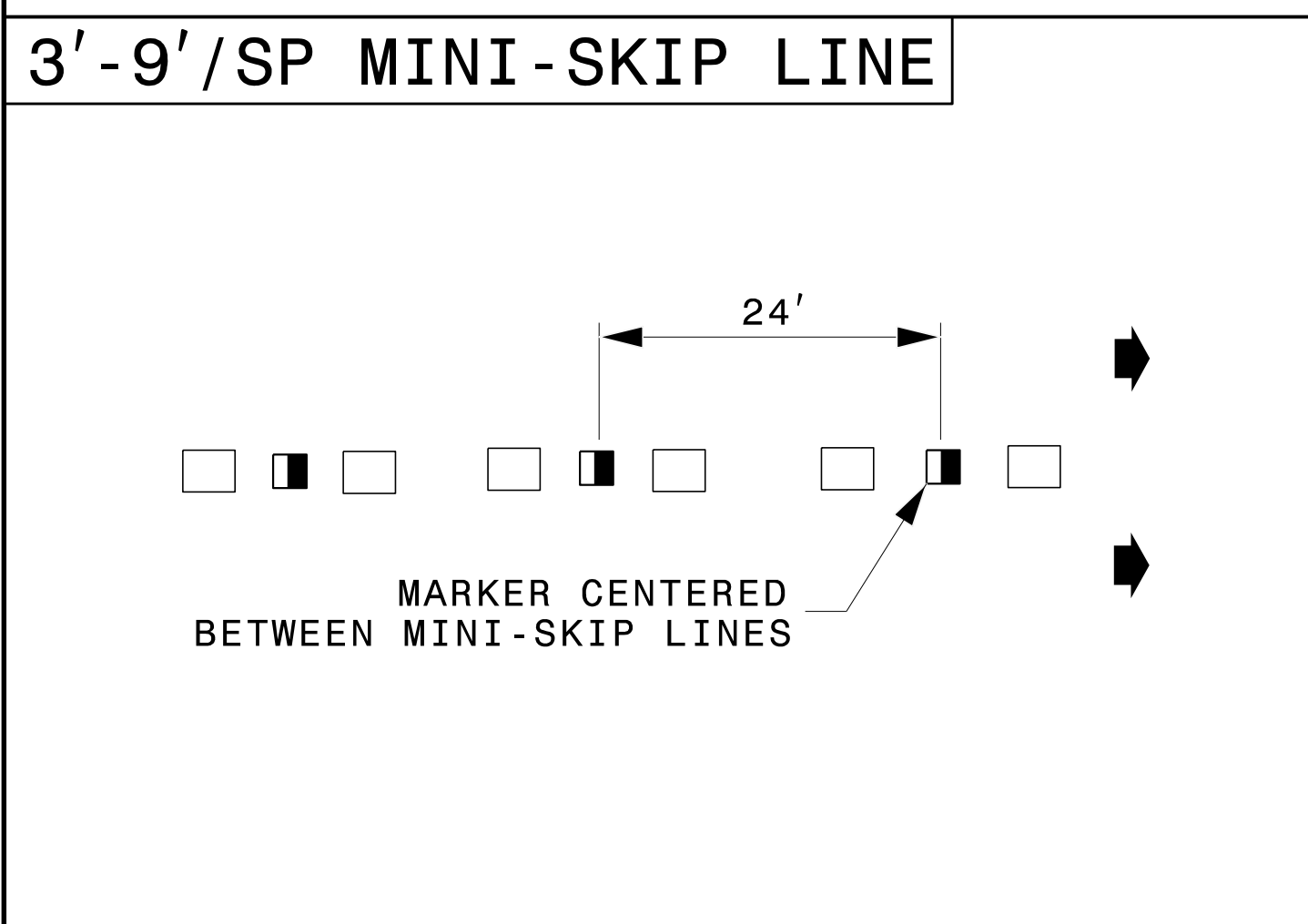
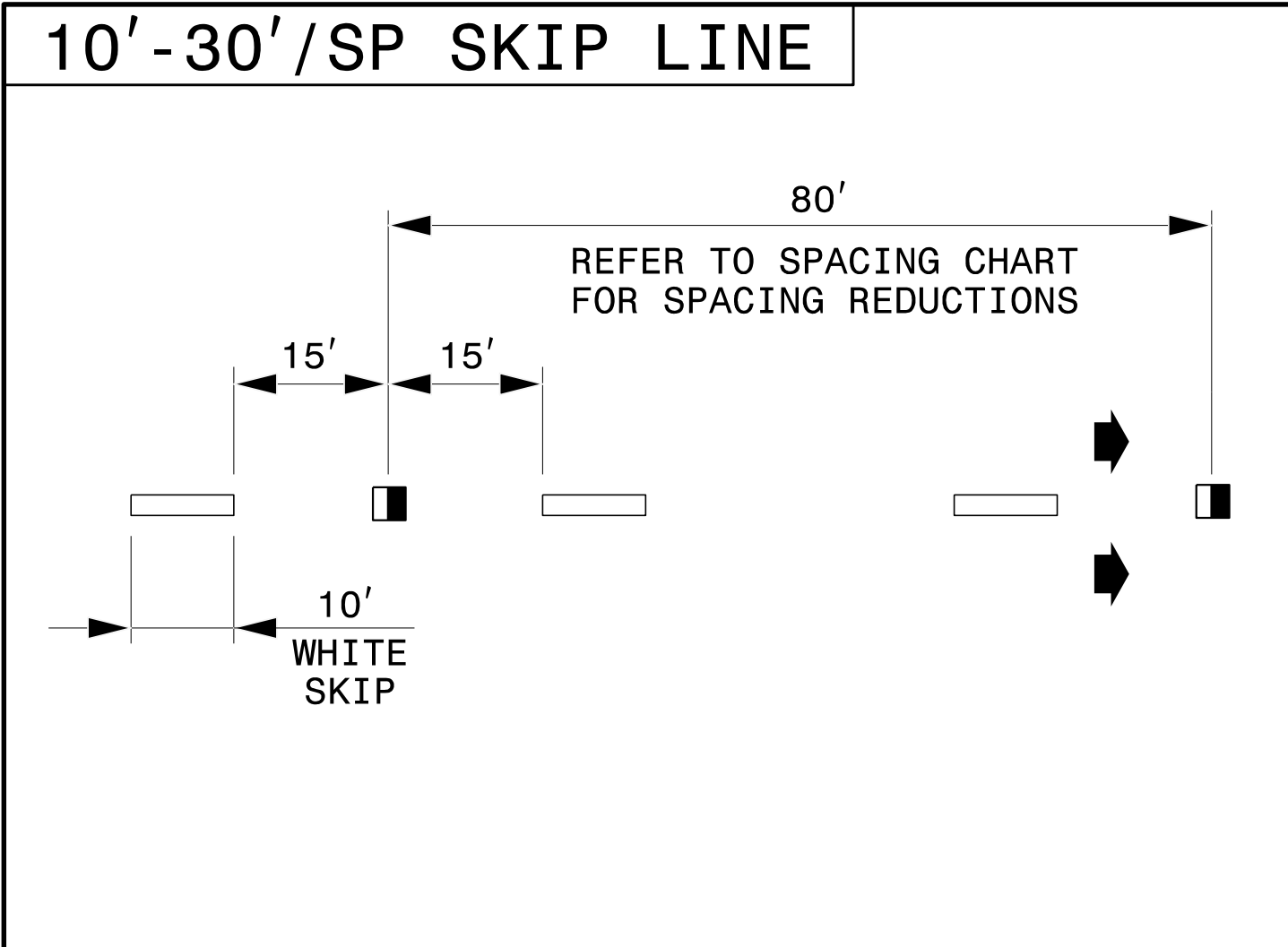

LEGEND

	CRYSTAL/RED PAVEMENT MARKER
	YELLOW/YELLOW PAVEMENT MARKER
	DIRECTION OF TRAFFIC FLOW

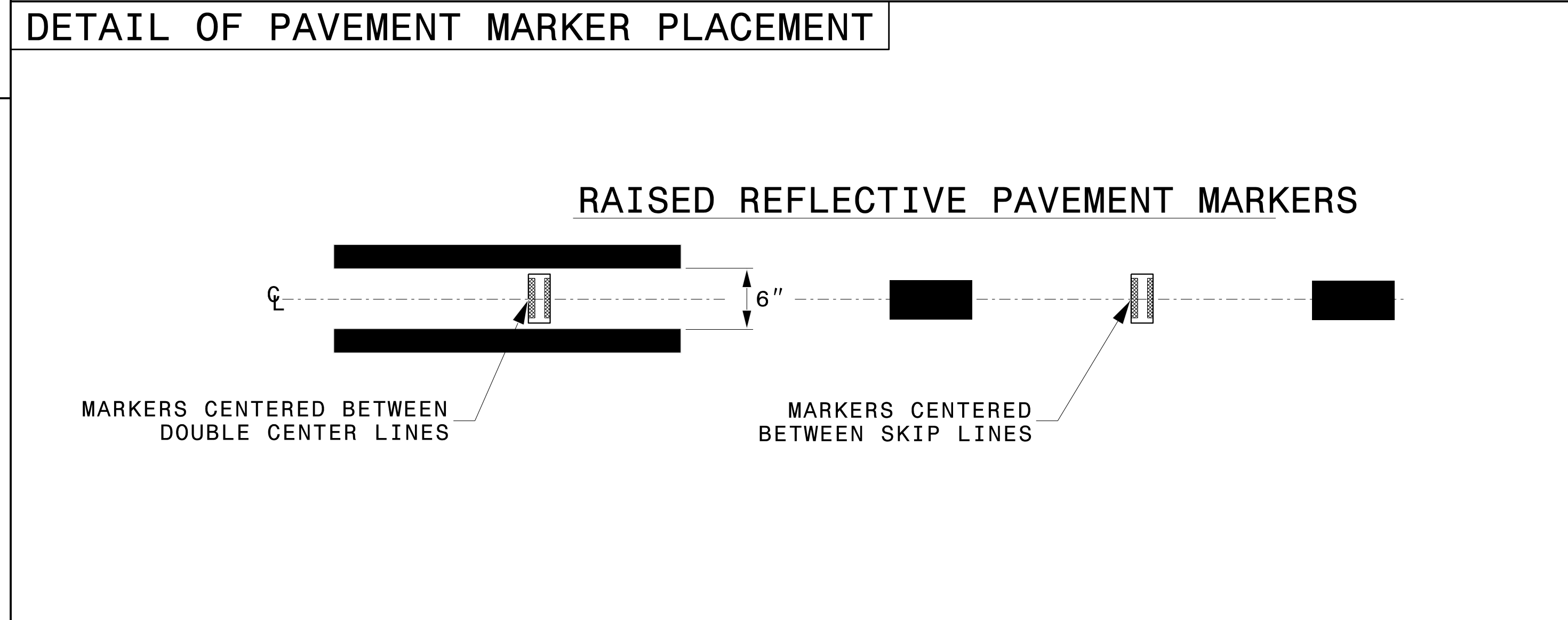
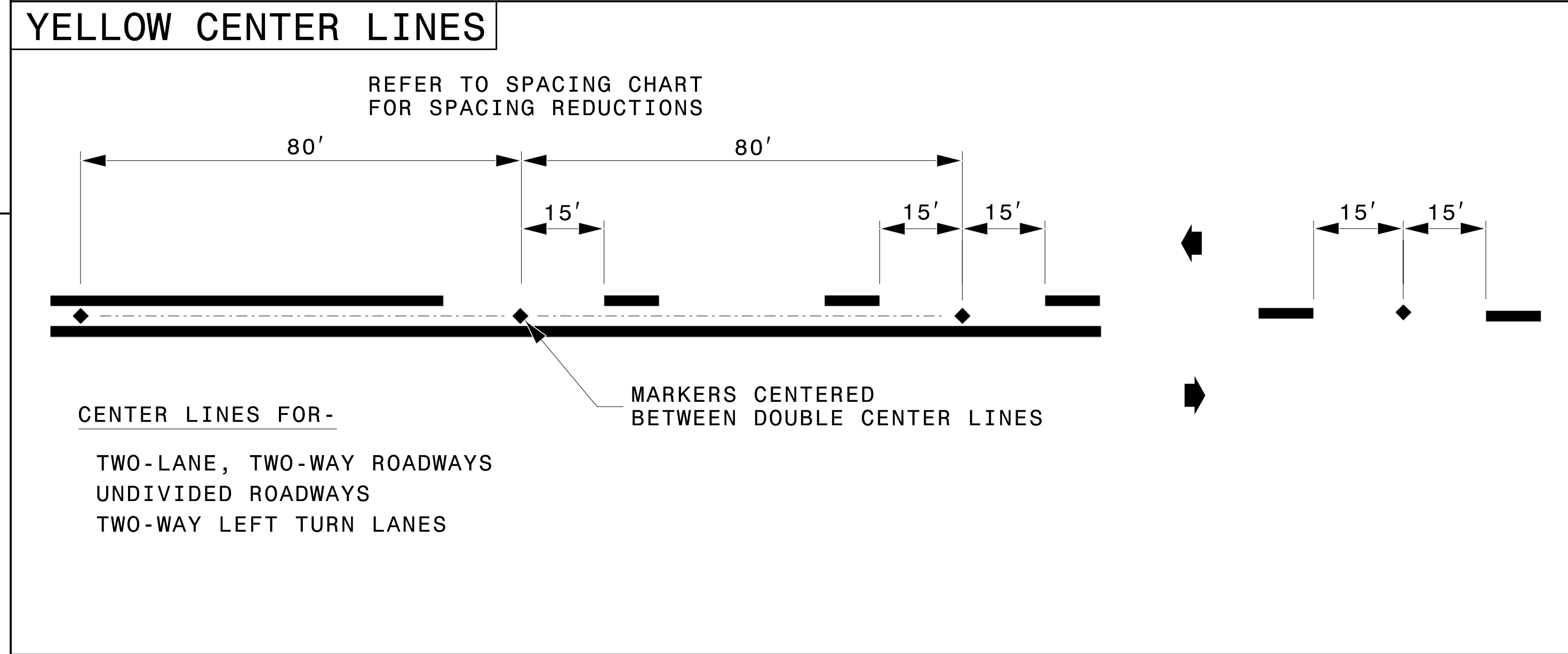
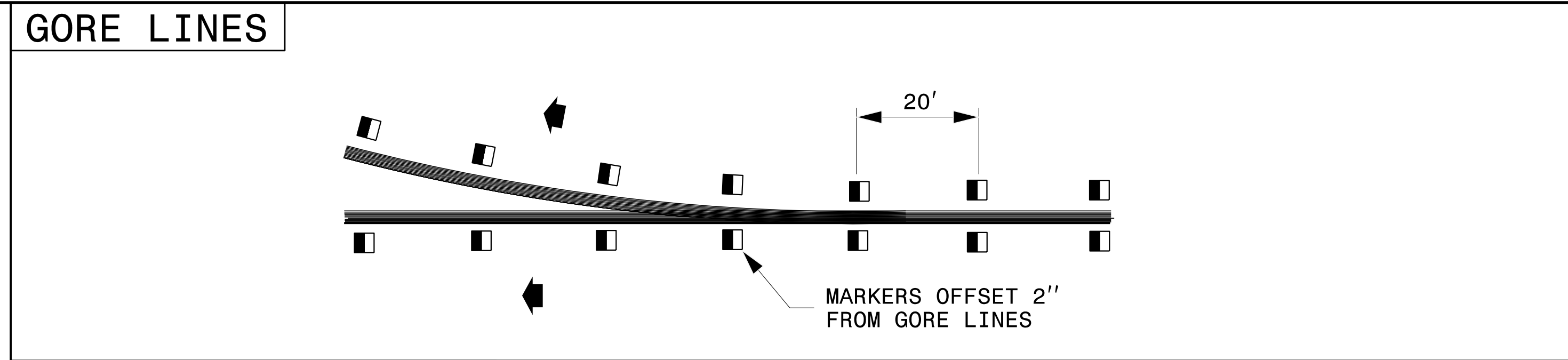

STATE OF NORTH CAROLINA
DEPT. OF TRANSPORTATION
DIVISION OF HIGHWAYS
RALEIGH, N.C.

ROADWAY DETAIL DRAWING FOR
RAISED PAVEMENT MARKERS
INSTALLATION SPACING

SHEET 2 OF 3
1250D01



CONTRACTS STANDARDS AND DEVELOPMENT UNIT
Office 919-707-8950 FAX 919-250-4119

SEE TITLE BLOCK

ORIGINAL BY: M.V. SPRINGER DATE: 2-15-24
 MODIFIED BY: DATE: _____
 CHECKED BY: DATE: _____
 FILE SPEC.: _____

APPROVED: _____
DATE: _____

SEAL
2/14/2026

Signed by:
Matthew A. Douglas
484263B2172AKC2

**DOCUMENT NOT CONSIDERED FINAL
UNLESS ALL SIGNATURES COMPLETED**

VIAS
INFRASTRUCTURE

220 HORIZON DRIVE, SUITE 117
RALEIGH, NC 27615
PHONE (727) 214-7698
LICENSE NO. P-2673
WWW.VIASINFRASTRUCTURE.COM

PAVEMENT MARKING SCHEDULE

SYMBOL	DESCRIPTION	SYMBOL	DESCRIPTION
THERMOPLASTIC (4", 90 MILS)			
T2	WHITE SOLID LANE LINE	T70	LEFT TURN ARROW
T3	10 FT WHITE SKIP	T71	RIGHT TURN ARROW
T4	3 FT. - 9 FT./SP WHITE MINISKIP	T72	STRAIGHT ARROW
T10	YELLOW EDGELINE	T74	COMBO RIGHT/STRAIGHT ARROW
T11	YELLOW SINGLE CENTER	SNOWPLOWABLE PAVEMENT MARKERS	
T12	10 FT YELLOW SKIP		
THERMOPLASTIC (8", 90 MILS)			
T42	YELLOW DIAGONAL	ME	YELLOW & YELLOW CRYSTAL & RED
T46	WHITE CROSSWALK LINE	MF	
THERMOPLASTIC (24", 90 MILS)			
T61	WHITE STOP BAR		
T62	WHITE CROSSWALK		

NOTE: USE NO TRACK MARKINGS FOR CROSSWALKS AS SHOWN IN ROADWAY STANDARD DRAWING 1205.7 SHEET 2 OF 2.

CURB RAMP TABLE

CURB RAMP	ALIGNMENT	STATION	OFFSET	RAMP TYPE	STD. DWG.
CR1	-L-	11+53	58' LT	4	848.06 SHEET 10 *

* SEE SPECIAL DETAIL IN ROADWAY PLANS IN LIEU OF STANDARD DRAWING

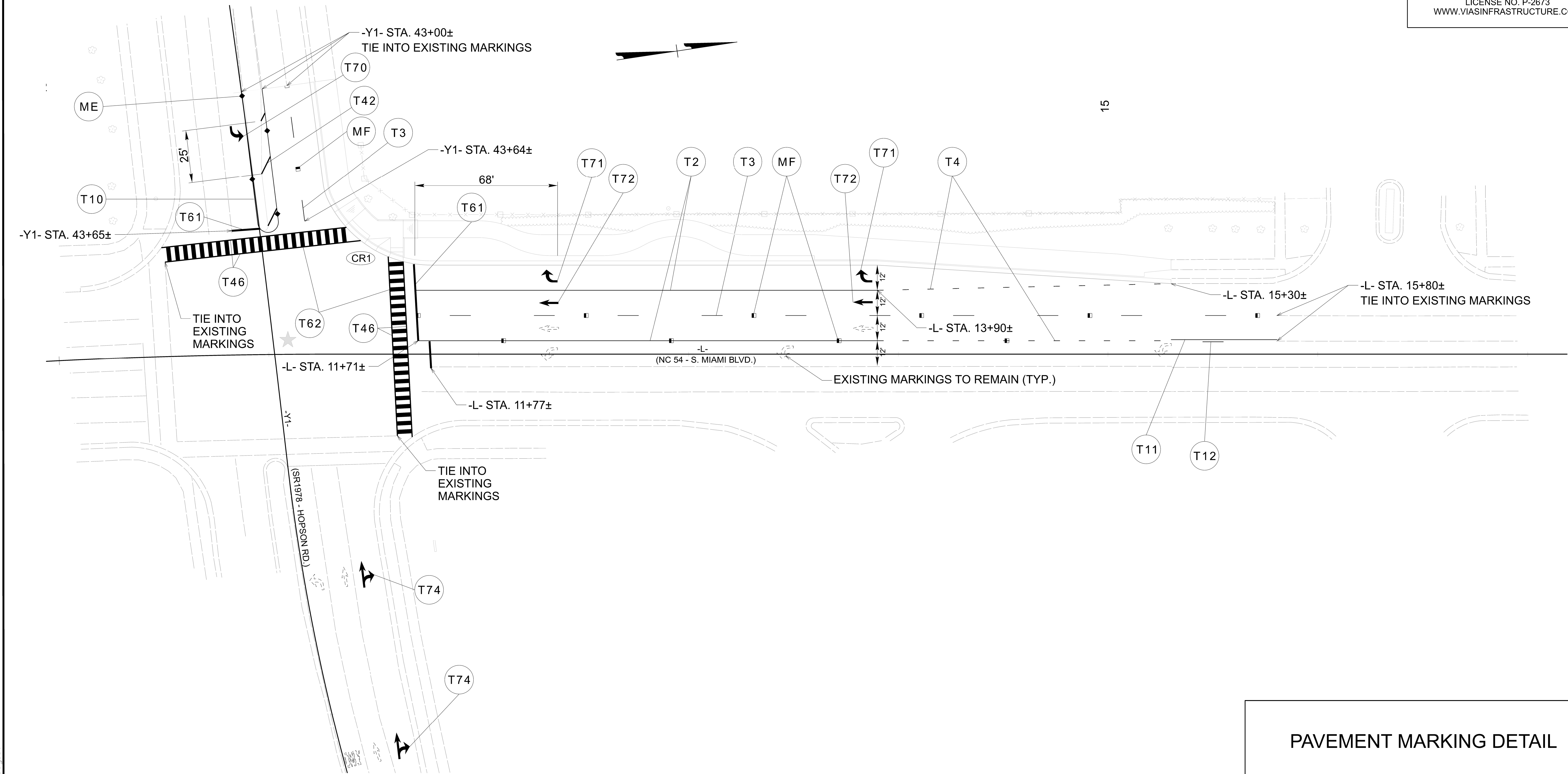

PAVEMENT MARKING DETAIL

6: VIAS Infrastructure\Engineering - Documents\03 Projects\PRJ23008H-NC05-SM-6105H\04-Design\SM-6105H\Signing and Delineation\ Pavement Marking\Design\SM-6105H\TTC_PMP02.dgn

TIP PROJECT: SM-5705AG

See Sheet 1A For Index of Sheets
See Sheet 1B For Conventional Plan Sheet Symbols

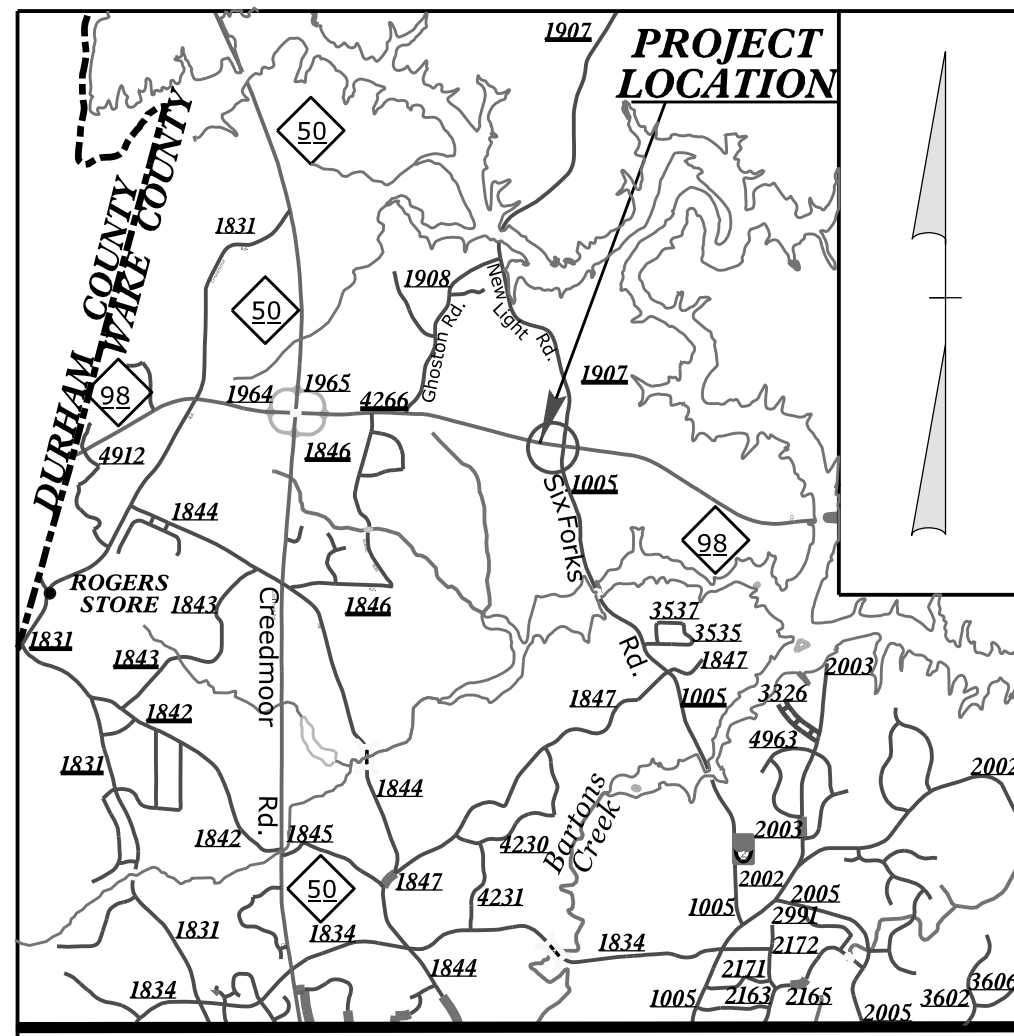

VICINITY MAP (NTS)

STATE OF NORTH CAROLINA DIVISION OF HIGHWAYS

WAKE COUNTY

EROSION CONTROL PLANS

LOCATION: NC 98 (DURHAM RD.) AT SR1005 (SIX FORKS RD.)

TYPE OF WORK: GRADING, DRAINAGE, PAVING, AND SIGNALS

STATE	STATE PROJECT REFERENCE NO.	SHEET NO.	TOTAL SHEETS
N.C.	SM-5705AG	EC-11	4
STATE PROJ. NO.	F. A. PROJ. NO.	DESCRIPTION	
48903.1.1		PE	
48903.2.1		R/W	
48903.3.1		CONST.	

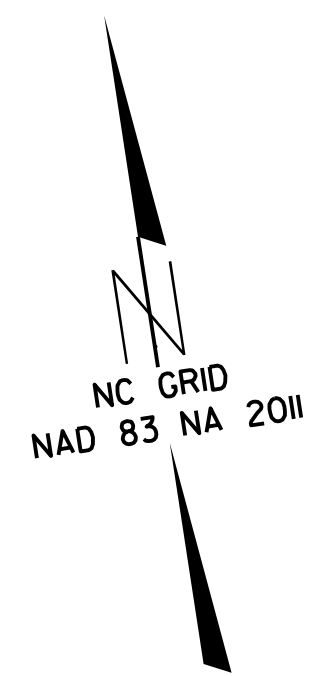
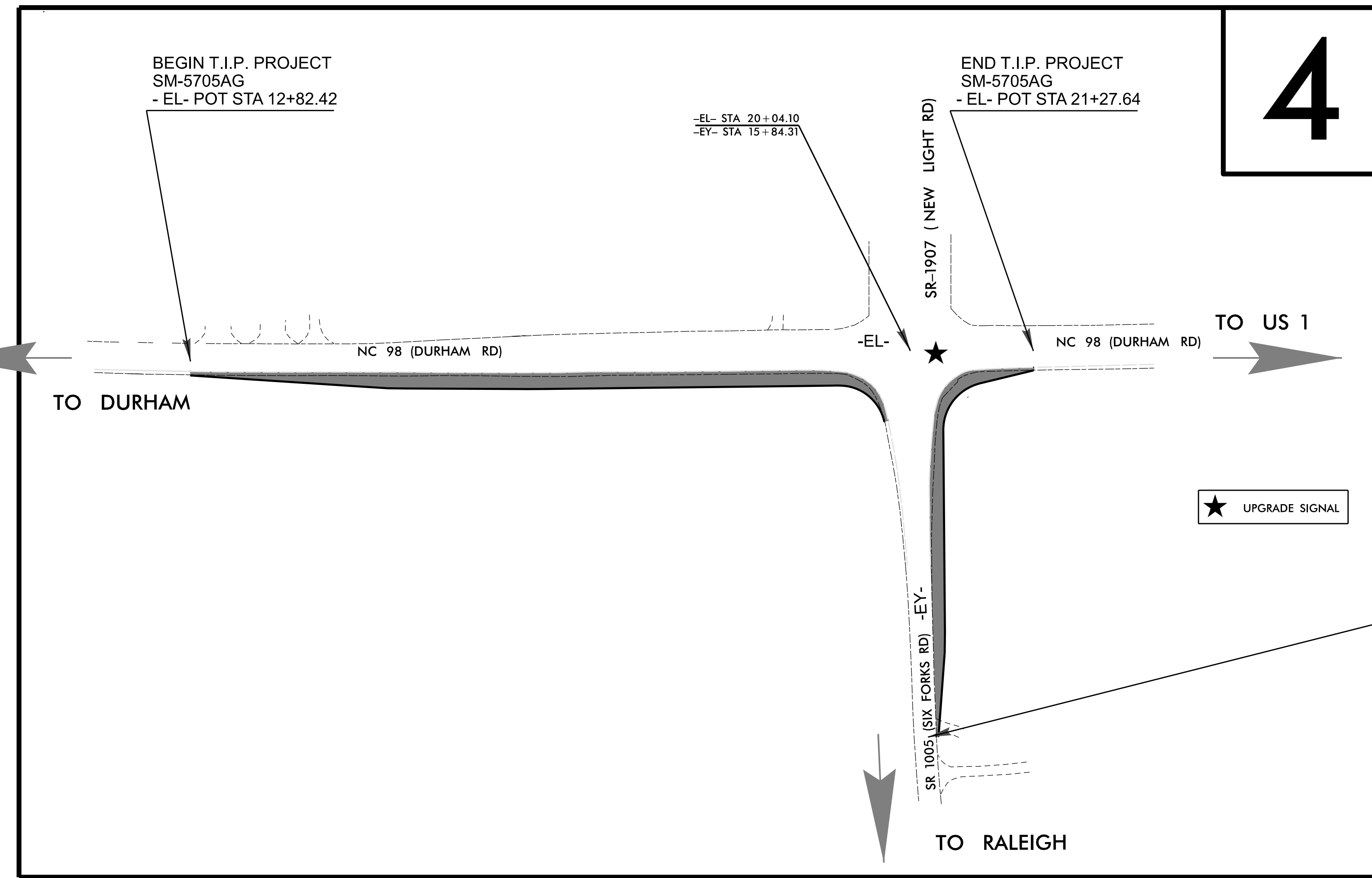

4

THIS PROJECT CONTAINS
EROSION CONTROL PLANS
FOR CLEARING AND
GRUBBING PHASE OF
CONSTRUCTION.

D W DAVIS
LEVEL IIIA NAME

3553
LEVEL IIIA CERTIFICATION NO.

DOCUMENT NOT CONSIDERED FINAL
UNLESS ALL SIGNATURES COMPLETED

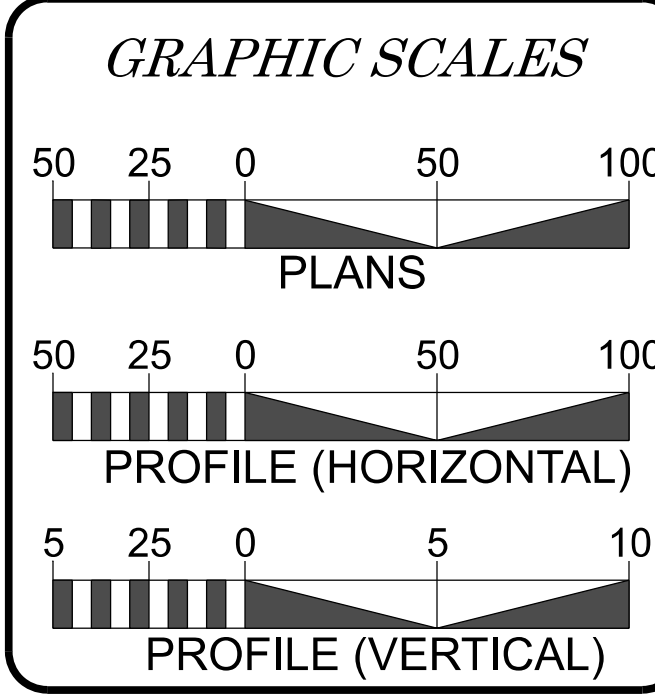

THESE EROSION AND SEDIMENT CONTROL PLANS COMPLY
WITH THE REGULATIONS SET FORTH BY THE
NCG-010000 GENERAL CONSTRUCTION PERMIT
ISSUED BY THE NORTH CAROLINA DEPARTMENT OF ENVIRONMENTAL
QUALITY DIVISION OF ENERGY, MINERAL,
AND LAND RESOURCES

Prepared in the Office of:
DIVISION OF HIGHWAYS
2612 N. Duke St., Durham, NC, 27704

2024 STANDARD SPECIFICATIONS

MATTHEW J NOLFO, P.E.
PROJECT ENGINEER

SUNIL J. PATEL
PROJECT DESIGN ENGINEER

STATE OF NORTH CAROLINA
FIFTH DIVISION
BECCA GALLAS, PE
DIVISION ENGINEER

DIVISION OF HIGHWAYS STATE OF NORTH CAROLINA

PROJECT REFERENCE NO. SM-5705AG	SHEET NO. EC-02
ROADWAY DESIGN ENGINEER	HYDRAULICS ENGINEER

EROSION & SEDIMENT CONTROL LEGEND

Std. #	Description	Symbol	Std. #	Description	Symbol
1605.01	Temporary Silt Fence		1633.01	Temporary Rock Silt Check Type A	
1606.01	Special Sediment Control Fence		1633.02	Temporary Rock Silt Check Type B	
1622.01	Temporary Berms and Slope Drains		1633.03	Temporary Rock Silt Check Type A with Excelsior Matting and Flocculant	
1630.02	Silt Basin Type B		1634.01	Temporary Rock Sediment Dam Type A	
1630.03	Temporary Silt Ditch		1634.02	Temporary Rock Sediment Dam Type B	
1630.04	Stilling Basin		1635.01	Rock Pipe Inlet Sediment Trap Type A	
1630.05	Temporary Diversion		1635.02	Rock Pipe Inlet Sediment Trap Type B	
1630.06	Special Stilling Basin		1636.01	Excelsior Wattle Check	
1630.07	Skimmer Basin		1636.01	Excelsior Wattle Check with Flocculant	
1630.08	Tiered Skimmer Basin		1636.01	Coir Fiber Wattle Check	
1630.09	Earthen Dam with Skimmer		1636.01	Coir Fiber Wattle Check with Flocculant	
	Infiltration Basin		1636.02	Silt Fence Excelsior Wattle Break	
	Rock Inlet Sediment Trap:			Silt Fence Coir Fiber Wattle Break	
1632.01	Type A		1636.02	Silt Fence Excelsior Wattle Break	
1632.02	Type B		1636.03	Excelsior Wattle Barrier	
1632.03	Type C		1636.03	Coir Fiber Wattle Barrier	

DIVISION OF HIGHWAYS
STATE OF NORTH CAROLINA

PROJECT REFERENCE NO.	SHEET NO.
<i>SM-5705AG</i>	<i>EC-3B</i>
ROADWAY DESIGN ENGINEER	HYDRAULICS ENGINEER

SOIL STABILIZATION TIMEFRAMES

<i>SITE DESCRIPTION</i>	<i>STABILIZATION TIME</i>	<i>TIMEFRAME EXCEPTIONS</i>
PERIMETER DIKES, SWALES, DITCHES AND SLOPES	7 DAYS	NONE
HIGH QUALITY WATER (HQW) ZONES	7 DAYS	NONE
SLOPES STEEPER THAN 3:1	7 DAYS	IF SLOPES ARE 10' OR LESS IN LENGTH AND ARE NOT STEEPER THAN 2:1, 14 DAYS ARE ALLOWED.
SLOPES 3:1 OR FLATTER	14 DAYS	7 DAYS FOR SLOPES GREATER THAN 50' IN LENGTH.
ALL OTHER AREAS WITH SLOPES FLATTER THAN 4:1	14 DAYS	NONE, EXCEPT FOR PERIMETERS AND HQW ZONES.



C & G PHASE

BEGIN TIP PROJECT
SM-5705AG
-EL- STA. 12 + 82.42

END TIP PROJECT
SM-5705AG
-EL- STA. 21 + 27.64

10

15

20

-EL- POB 10+00.00
-EL- STA. 10+00.00

-EL- PC 11+26.34
-EL- PC 11+26.34

-EL- PT 12+88.35
-EL- PT 12+88.35

-EL- PC 13+96.70
-EL- PC 13+96.70

-EL- PT 14+34.94
-EL- PT 14+34.94

-EL- STA 20 + 04.10
-EY- STA 15 + 84.31

-EL- POE 22+50.92
-EL- STA. 22+50.92

S78°20'30.5"E

S81°00'02.4"E

S82°44'57.4"E

S82°11'57.4"E

ACCESS EASEMENT (BM 2005 PG 119)

-EL- STA 14 + 80.32

REMOVE APPROX. 10'
OF EX. CONCRETE DITCH
TIE PROP. 3GI TO REMAINING
CONCRETE DITCH

-EL + 80.99
TIE TO EXIST

INSTALL TEMP SILT FENCE
APPROX 2' BEHIND
TOE OF SLOPE

INSTALL SSCF
APPROX 2' BEHIND
PDE

100' TAPER

-EY- PT 12+00.17
-EY- PT 12+00.17

-EY- STA 11 + 95.86

BEGIN CONST
-EY- STA 11 + 90.00

-EY- PC 10 + 77.20

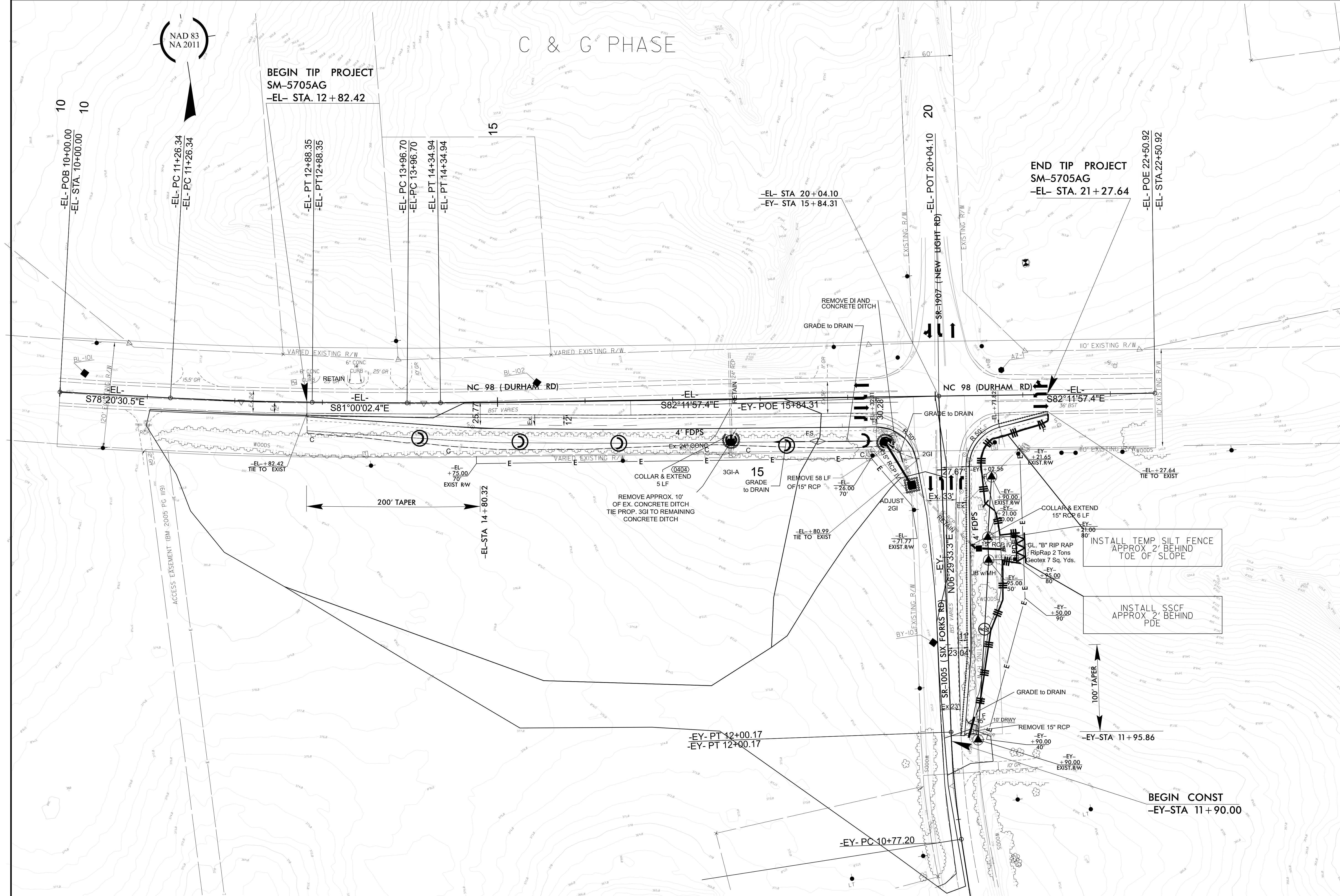

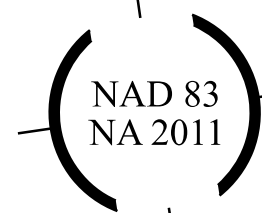

FINAL PHASE

BEGIN TIP PROJECT
SM-5705AG
-EL- STA. 12 + 82.42

END TIP PROJECT
SM-5705AG
-EL- STA. 21 + 27.64

10

-EL- POB 10+00.00
-EL- STA. 10+00.00

-EL- PC 11+26.34
-EL- PC 11+26.34

-EL- PT 12+88.35
-EL- PT 12+88.35

-EL- PC 13+96.70
-EL- PC 13+96.70

-EL- PT 14+34.94
-EL- PT 14+34.94

15

-EL- STA 20 + 04.10
-EY- STA 15 + 84.31

20

-EL- POT 20+04.10
SR-1907 (NEW LIGHT RD)

-EL- POE 22+50.92
-EL- STA. 22+50.92

NC 98 (DURHAM RD)

ACCESS EASEMENT (BM 2005 PG 118)

200' TAPER

-EL- STA 14 + 80.32

REMOVE APPROX. 10' OF EX. CONCRETE DITCH TIE PROP. 3GI TO REMAINING CONCRETE DITCH

15
GRADE to DRAIN

REMOVE 58 LF OF 15" RCP

ADJUST 2GI

INSTALL TEMP SILT FENCE APPROX 2' BEHIND TOE OF SLOPE

INSTALL SSCF APPROX 2' BEHIND PDE

100' TAPER

-EY- STA 11 + 95.86

BEGIN CONST
-EY- STA 11 + 90.00

-EY- PT 12+00.17
-EY- PT 12+00.17

-EY- PC 10+77.20

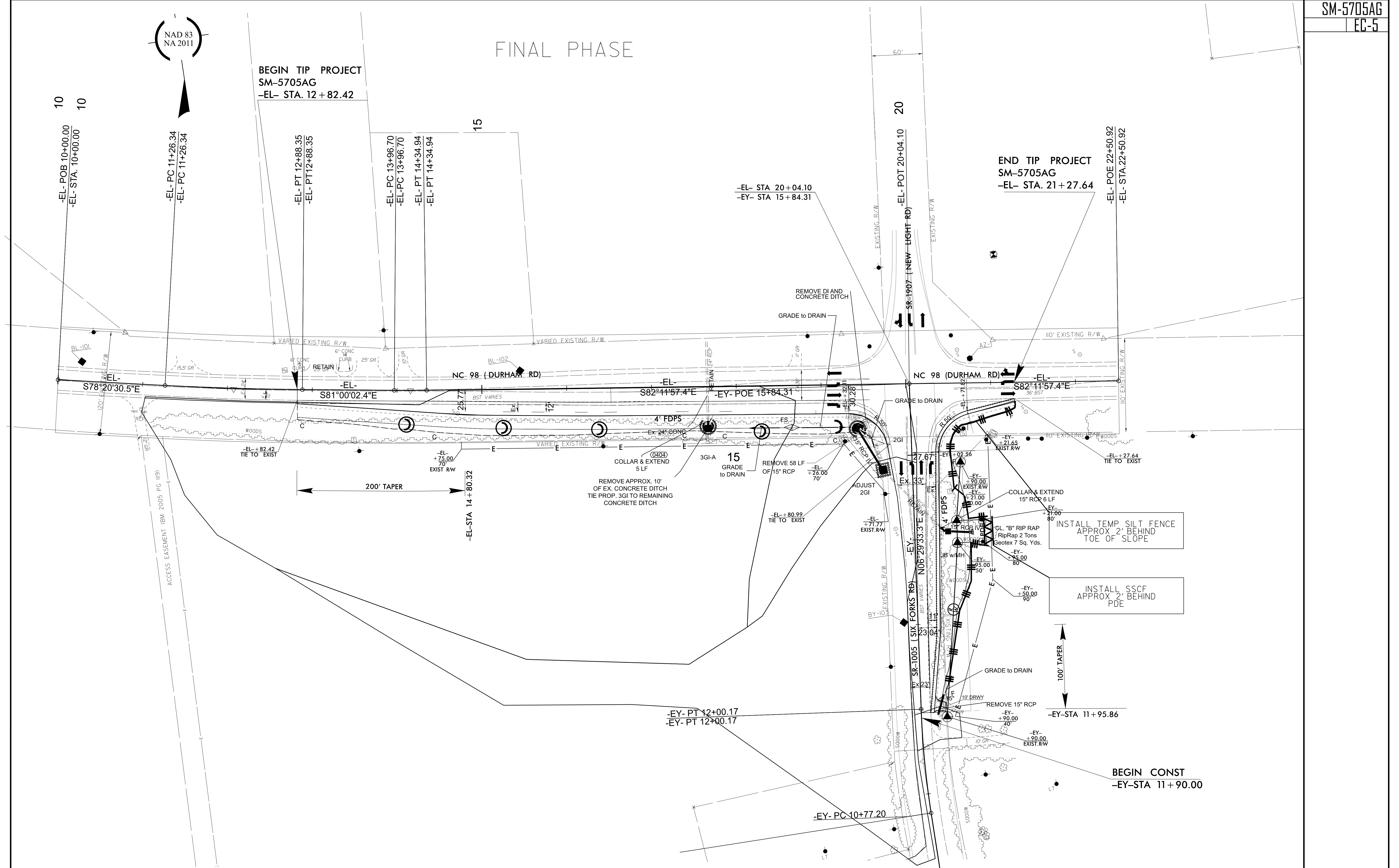

TIP PROJECT: SM-6105H/ HS-2405AH

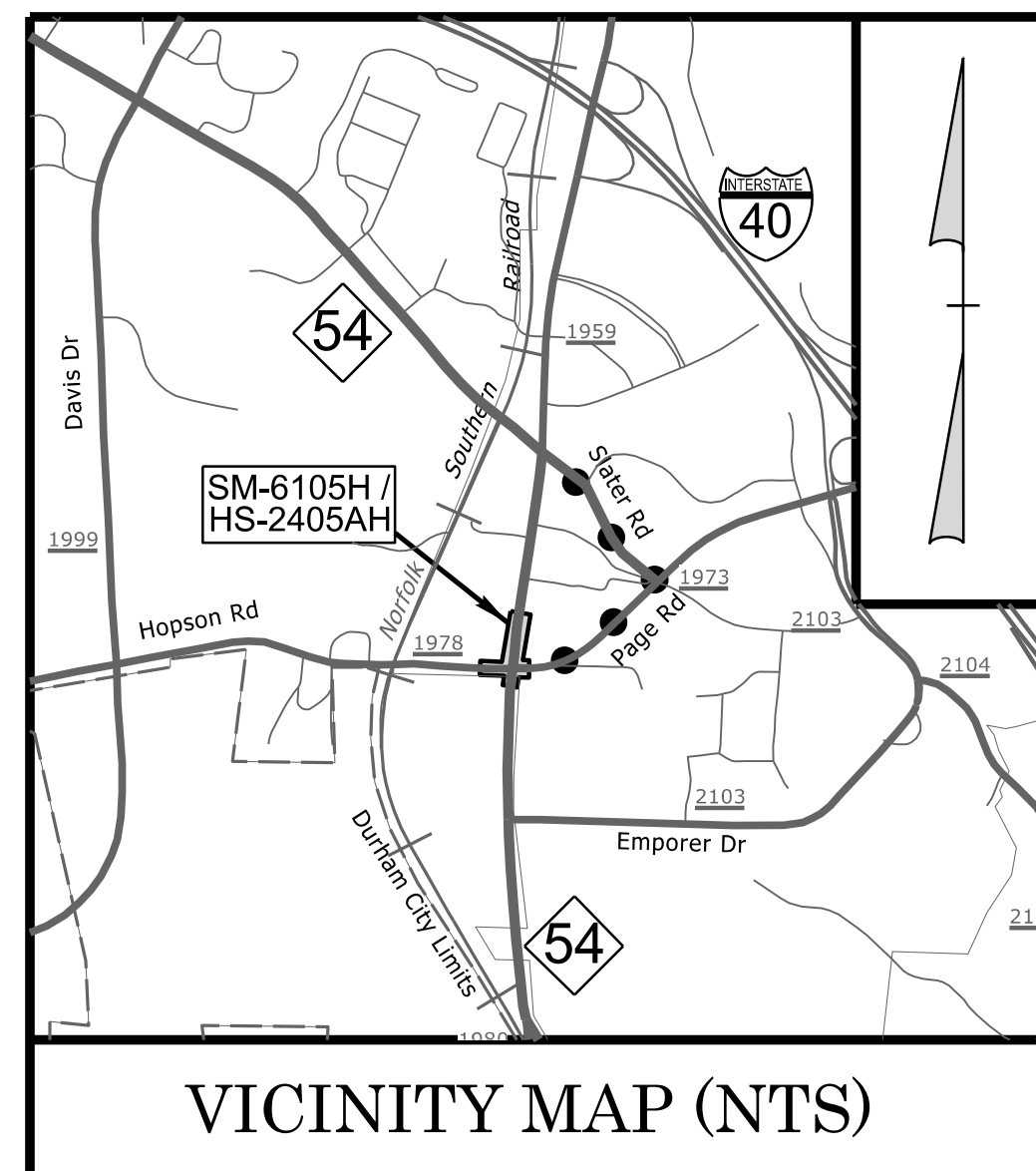

VICINITY MAP (NTS)

● ● ● OFFSITE TRUCK DETOUR

STATE OF NORTH CAROLINA
DIVISION OF HIGHWAYS

PLAN FOR PROPOSED
HIGHWAY EROSION CONTROL

DURHAM COUNTY

LOCATION: NC 54 (S. MIAMI BLVD.) AT SR 1978 (HOPSON RD.)
CONSTRUCT A SOUTHBOUND RIGHT TURN LANE
ON NC 54

TYPE OF WORK: GRADING, PAVING, DRAINAGE,
& WIDENING

STATE	STATE PROJECT REFERENCE NO.	SHEET NO.	TOTAL SHEETS
N.C.	SM-6105H/ HS-2405AH	EC-1	
STATE PROJ. NO.	F.A. PROJ. NO.	DESCRIPTION	

THIS PROJECT CONTAINS
EROSION CONTROL PLANS
FOR CLEARING AND
GRUBBING PHASE OF
CONSTRUCTION.

THIS PROJECT HAS
BEEN DESIGNED TO
SENSITIVE WATERSHED
STANDARDS.

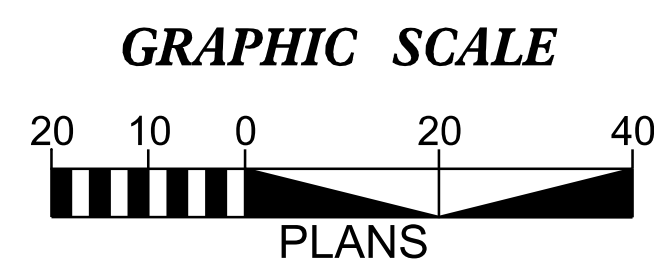
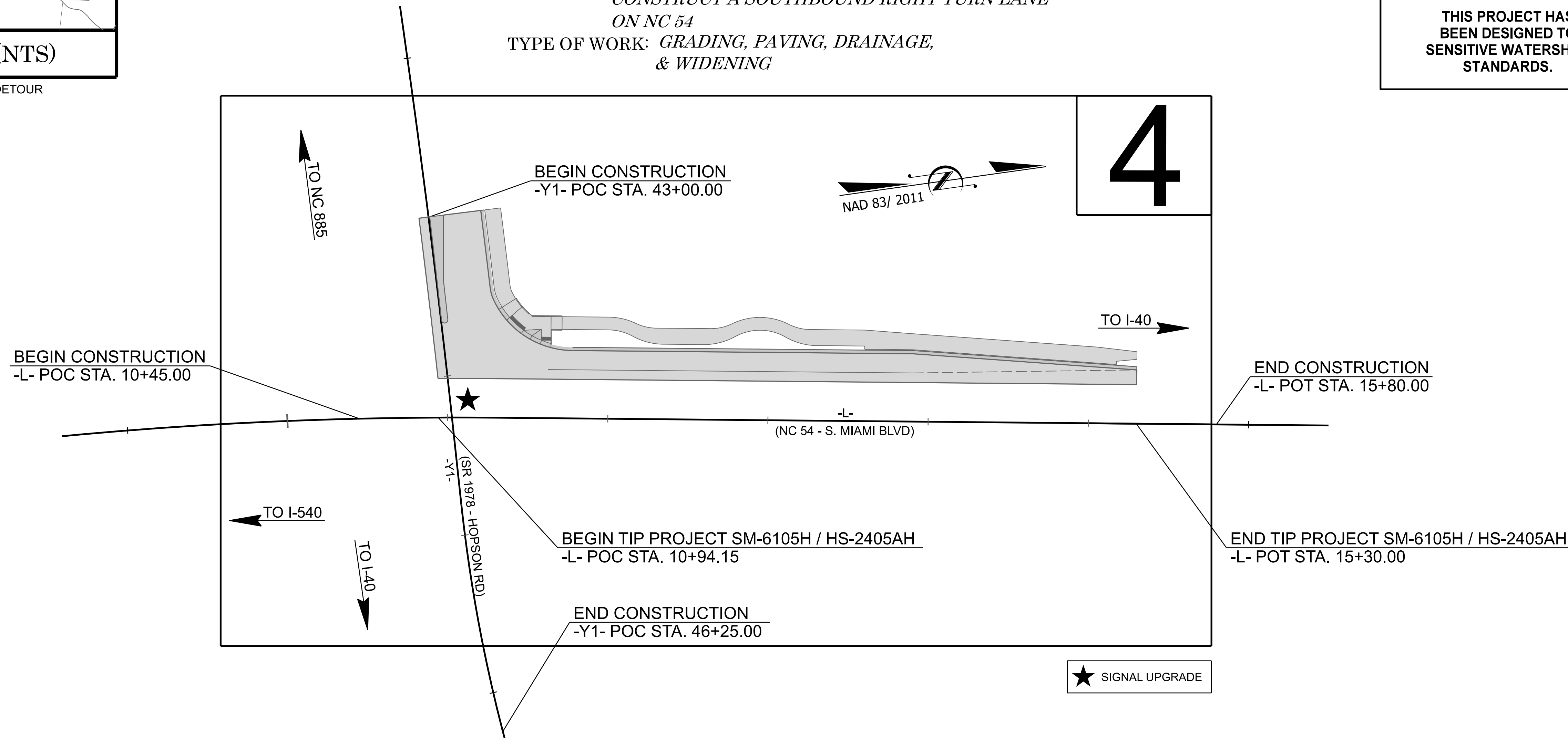

THESE EROSION AND SEDIMENT CONTROL PLANS COMPLY WITH THE REGULATIONS SET FORTH BY THE NCG 010000 GENERAL STORMWATER CONSTRUCTION PERMIT ISSUED BY THE NORTH CAROLINA DEPARTMENT OF ENVIRONMENTAL QUALITY DIVISION OF ENERGY, MINERAL, AND LAND RESOURCES.



Prepared in the Office of:
WETHERILL ENGINEERING, INC.
1223 JONES FRANKLIN ROAD
RALEIGH, NC 27606

Designed by:
KATIE ESTEP 4485
NAME LEVEL III CERTIFICATION NO.

Roadway Standard Drawings

The "Roadway Standard Drawings"- Roadway Design Unit - N. C. Department of Transportation - Raleigh, N. C., dated January 2024 and the latest revision thereto are applicable to this project and by reference hereby are considered a part of these plans.

DIVISION OF HIGHWAYS STATE OF NORTH CAROLINA

PROJECT REFERENCE NO. SM-6105H/ HS-2405AH	SHEET NO. EC-02

EROSION & SEDIMENT CONTROL LEGEND

<u>Std. #</u>	<u>Description</u>	<u>Symbol</u>	<u>Std. #</u>	<u>Description</u>	<u>Symbol</u>
1605.01	Temporary Silt Fence		1633.01	Temporary Rock Silt Check Type A	
1606.01	Special Sediment Control Fence		1633.02	Temporary Rock Silt Check Type B	
1622.01	Temporary Berms and Slope Drains		1633.03	Temporary Rock Silt Check Type A with Excelsior Matting and Flocculant	
1630.02	Silt Basin Type B		1634.01	Temporary Rock Sediment Dam Type A	
1630.03	Temporary Silt Ditch		1634.02	Temporary Rock Sediment Dam Type B	
1630.04	Stilling Basin		1635.01	Rock Pipe Inlet Sediment Trap Type A	
1630.05	Temporary Diversion		1635.02	Rock Pipe Inlet Sediment Trap Type B	
1630.06	Special Stilling Basin		1636.01	Excelsior Wattle Check	
1630.07	Skimmer Basin		1636.01	Excelsior Wattle Check with Flocculant	
1630.08	Tiered Skimmer Basin		1636.01	Coir Fiber Wattle Check	
1630.09	Earthen Dam with Skimmer		1636.01	Coir Fiber Wattle Check with Flocculant	
	Infiltration Basin		1636.02	Silt Fence Excelsior Wattle Break	
	Rock Inlet Sediment Trap:			Silt Fence Coir Fiber Wattle Break	
1632.01	Type A		1636.03	Excelsior Wattle Barrier	
1632.02	Type B		1636.03	Coir Fiber Wattle Barrier	
1632.03	Type C				

PROJECT REFERENCE NO.	SHEET NO.
SM-6105H/ HS-2405AH	EC-2A
R/W SHEET NO.	

ONSITE CONCRETE WASHOUT STRUCTURE WITH LINER

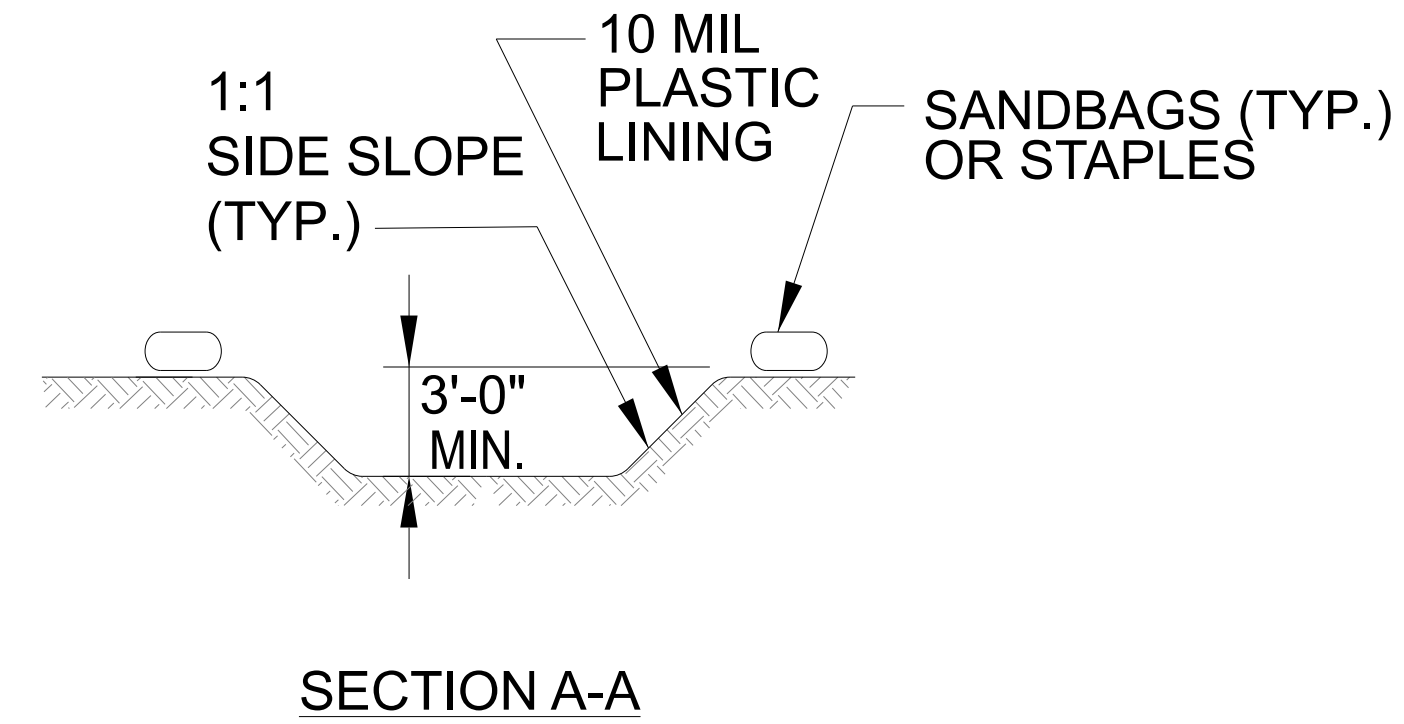
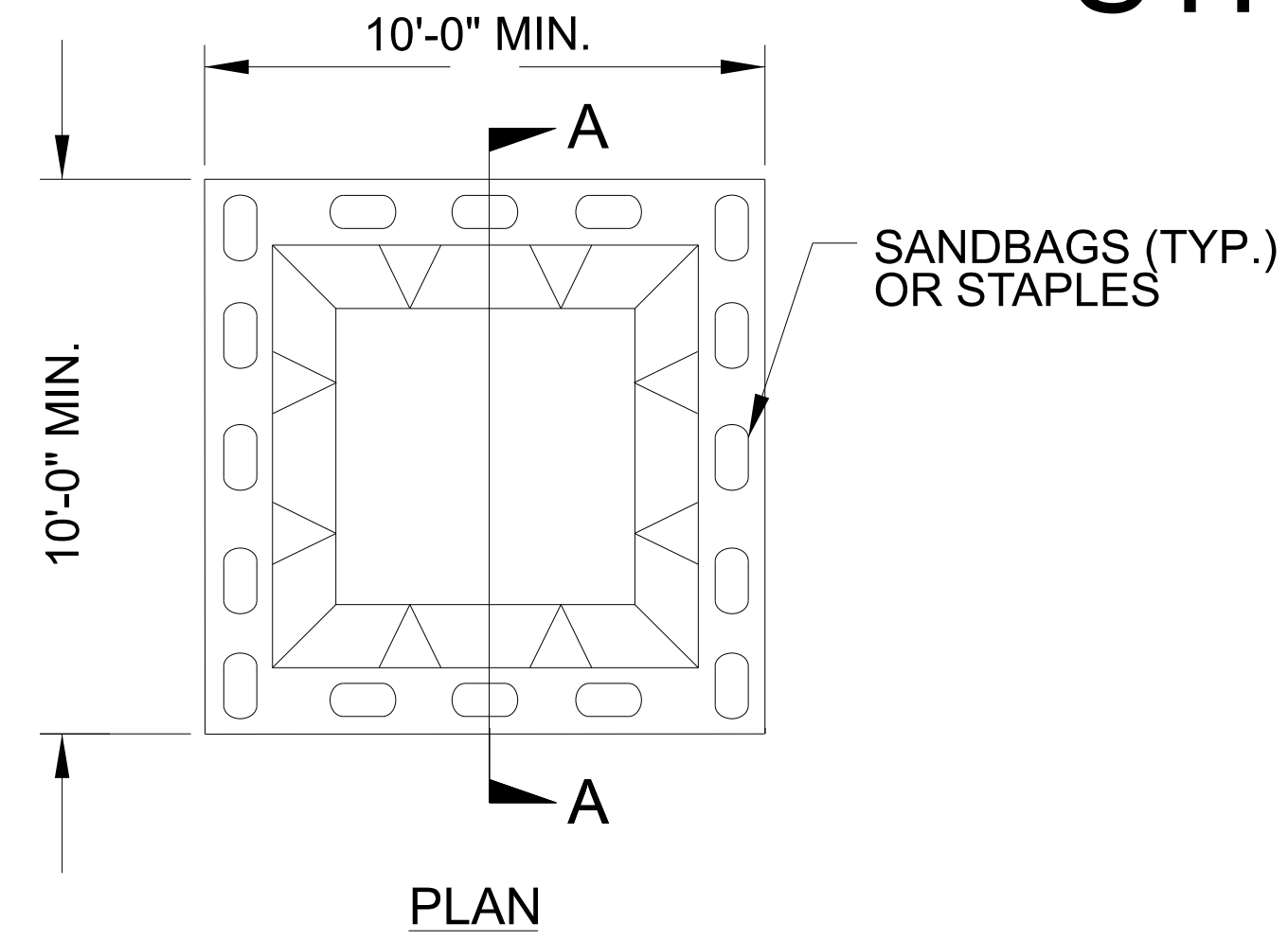

BELOW GRADE WASHOUT STRUCTURE
NOT TO SCALE

- NOTES:
1. ACTUAL LOCATION DETERMINED IN FIELD
 2. THE CONCRETE WASHOUT STRUCTURES SHALL BE MAINTAINED WHEN THE LIQUID AND/OR SOLID REACHES 75% OF THE STRUCTURES CAPACITY TO PROVIDE ADEQUATE HOLDING CAPACITY WITH A MINIMUM 12 INCHES OF FREEBOARD.
 3. CONCRETE WASHOUT STRUCTURE NEEDS TO BE CLEARLY MARKED WITH SIGNAGE NOTING DEVICE.

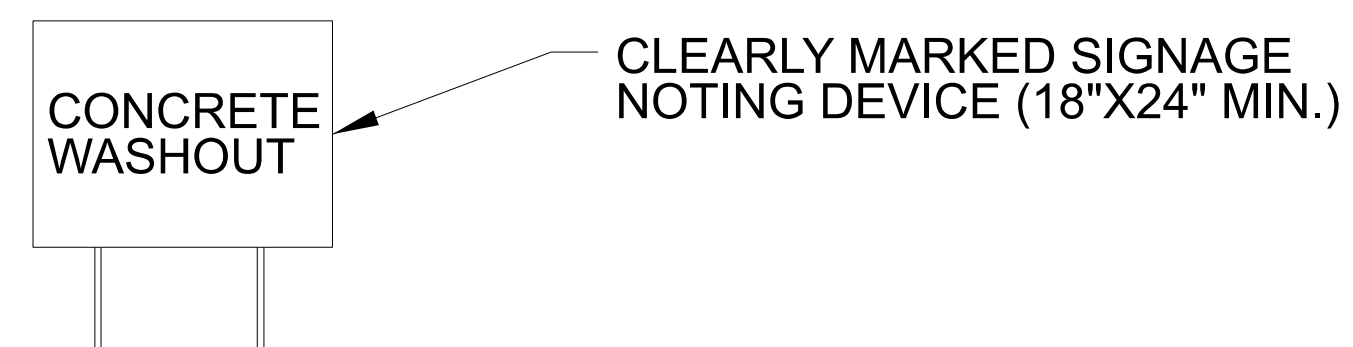
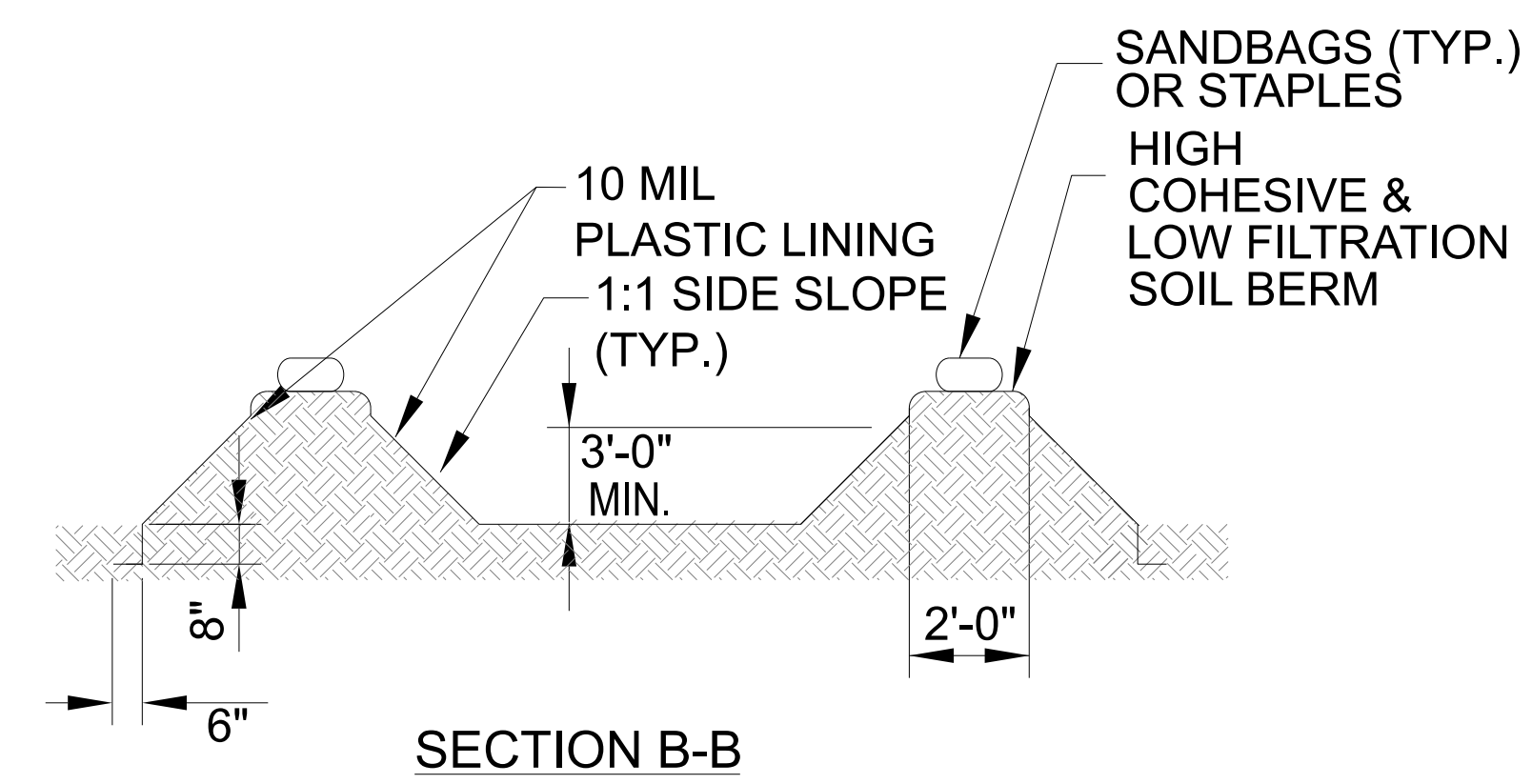
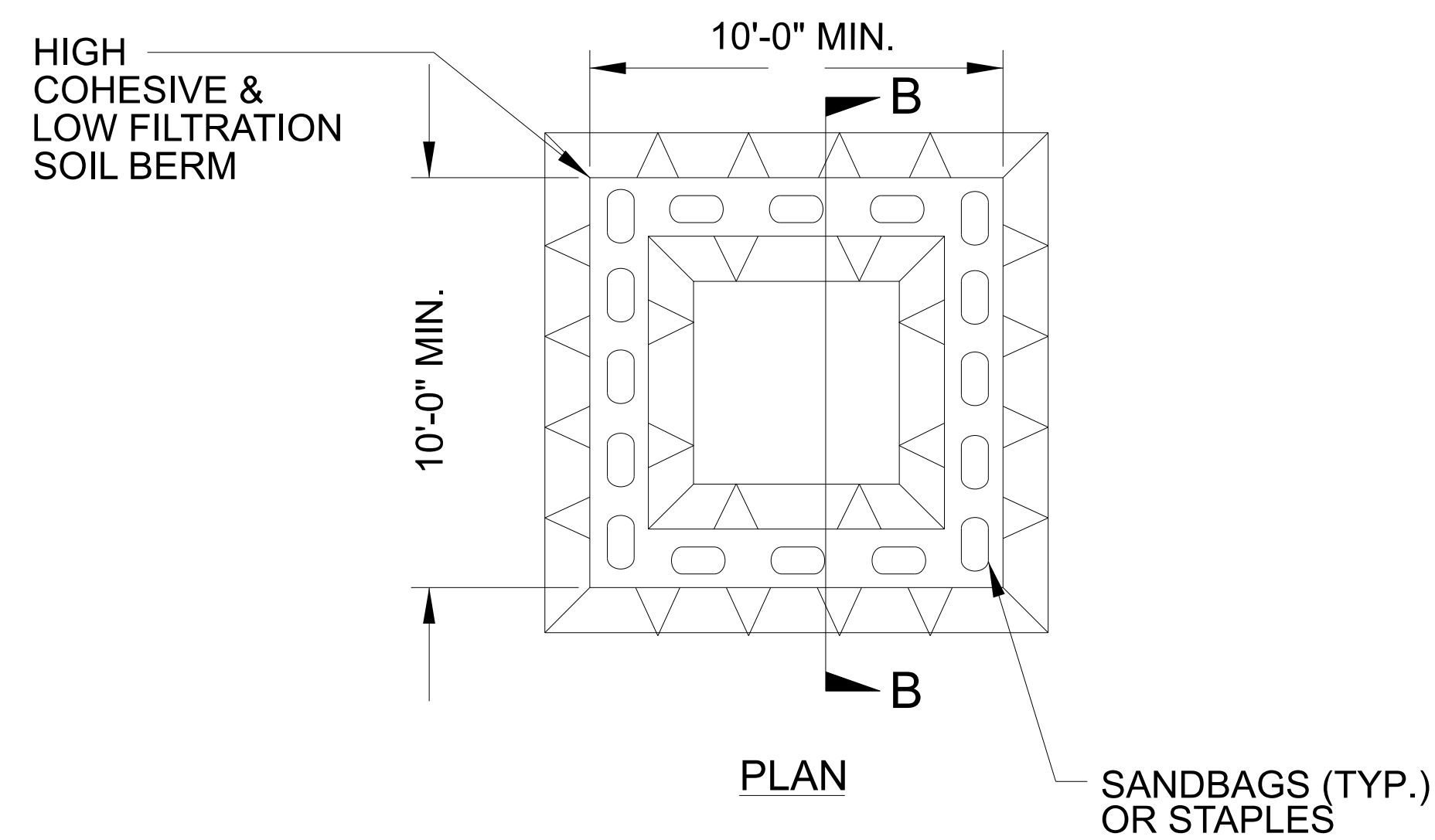

ABOVE GRADE WASHOUT STRUCTURE
NOT TO SCALE

- NOTES:
1. ACTUAL LOCATION DETERMINED IN FIELD
 2. THE CONCRETE WASHOUT STRUCTURES SHALL BE MAINTAINED WHEN THE LIQUID AND/OR SOLID REACHES 75% OF THE STRUCTURES CAPACITY TO PROVIDE ADEQUATE HOLDING CAPACITY WITH A MINIMUM 12 INCHES OF FREEBOARD.
 3. CONCRETE WASHOUT STRUCTURE NEEDS TO BE CLEARLY MARKED WITH SIGNAGE NOTING DEVICE.

DIVISION OF HIGHWAYS
STATE OF NORTH CAROLINA

PROJECT REFERENCE NO.	SHEET NO.
SM-6105H/ HS-2405AH	EC-3

SOIL STABILIZATION TIMEFRAMES

<i>SITE DESCRIPTION</i>	<i>STABILIZATION TIME</i>	<i>TIMEFRAME EXCEPTIONS</i>
PERIMETER DIKES, SWALES, DITCHES AND SLOPES	7 DAYS	NONE
HIGH QUALITY WATER (HQW) ZONES	7 DAYS	NONE
SLOPES STEEPER THAN 3:1	7 DAYS	IF SLOPES ARE 10' OR LESS IN LENGTH AND ARE NOT STEEPER THAN 2:1, 14 DAYS ARE ALLOWED.
SLOPES 3:1 TO 4:1	14 DAYS	7 DAYS FOR SLOPES GREATER THAN 50' IN LENGTH WITH SLOPES STEEPER THAN 4:1. 7 DAYS FOR PERIMETER DIKES, SWALES, DITCHES PERIMETER SLOPES, AND HQW ZONES
ALL OTHER AREAS WITH SLOPES FLATTER THAN 4:1	14 DAYS	7 DAYS FOR PERIMETER DIKES, SWALES, DITCHES PERIMETER SLOPES, AND HQW ZONES

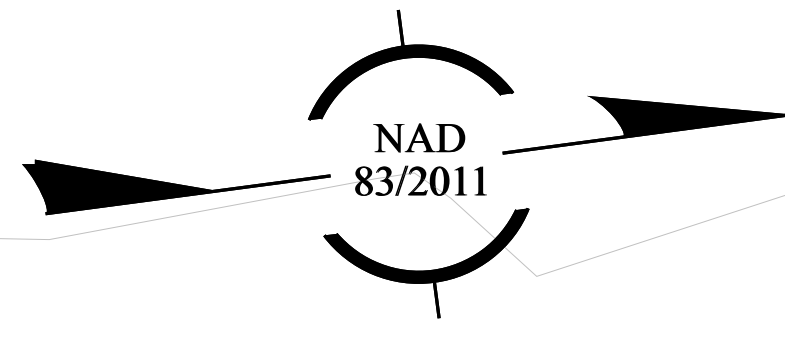

Exist CB
Sta= Y1 42+75
DA= 0.074 Ac
C= 0.9
I/hr=4 in/hr
Q=0.27 cfs
Spread= 2.5 ft
Bypass= 0.0 cfs
Rdwy. Grade=1.0 %
Cross Slope= 0.02

CLEARING & GRUBBING
EROSION CONTROL FOR
CONSTRUCTION SHEET 4

BEGIN CONSTRUCTION
-Y1- POC STA. 43+00.00

END CONSTRUCTION
-Y1- POC STA. 44+01.59

BEGIN TIP PROJECT SM-6105H / HS-2405AH
-L- POC STA. 10+94.15

END TIP PROJECT SM-6105H / HS-2405AH
-L- POT STA. 15+30.00

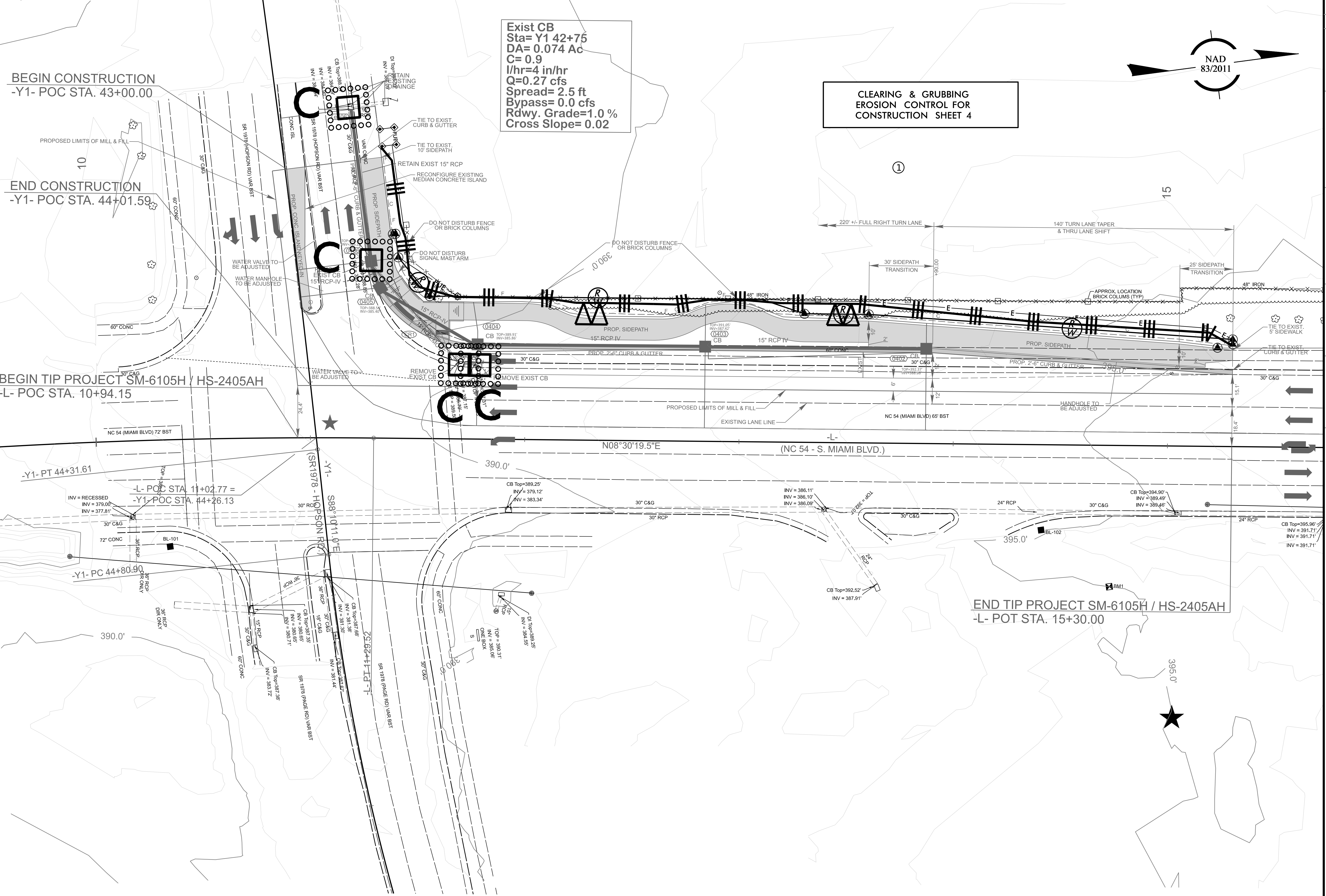

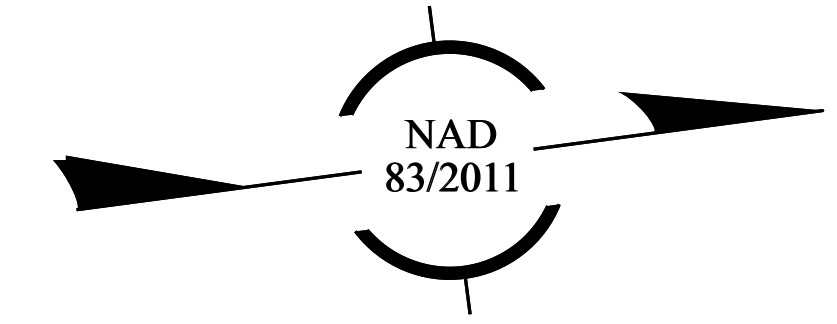
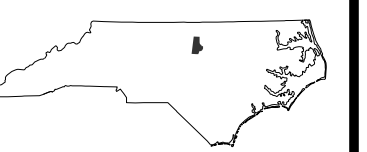

BEGIN CONSTRUCTION
-Y1- POC STA. 43+00.00

END CONSTRUCTION
-Y1- POC STA. 44+01.59

BEGIN TIP PROJECT SM-6105H / HS-2405AH
-L- POC STA. 10+94.15

END TIP PROJECT SM-6105H / HS-2405AH
-L- POT STA. 15+30.00

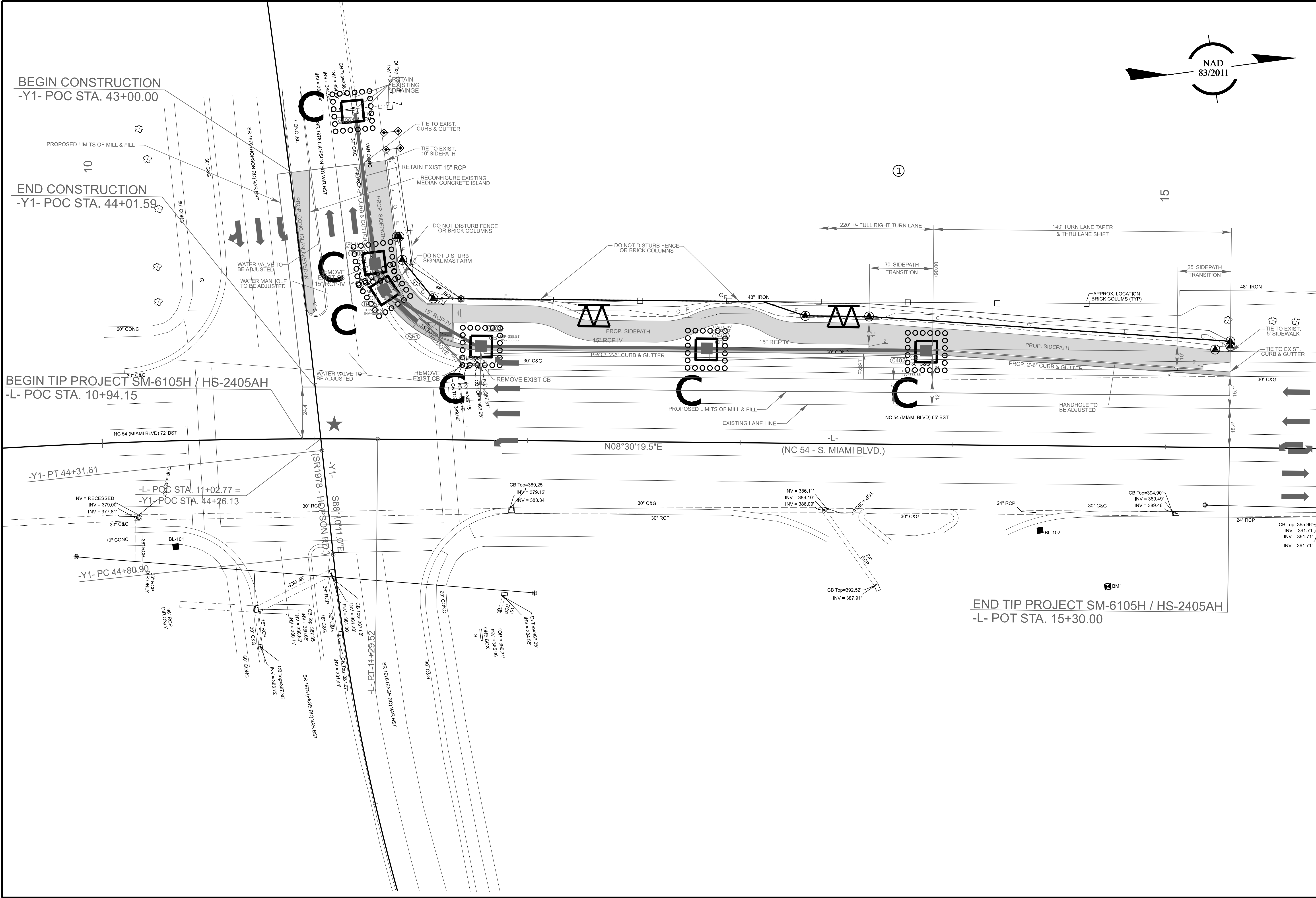

ROADWAY DESIGN
PREPARED BY



5553 OLD STILL ROAD
WAKE FOREST, NC 27587
PHONE (727) 214-7698
LICENCE NO P-2673
WWW.VIASINFRASTRUCTURE.COM

HYDRAULIC DESIGN
PREPARED BY



1223 Jones Franklin Rd.
Raleigh, N.C. 27606
License No. F-0377
Bus: 919 851 8077
Fax: 919 851 8107

REVISIONS

2/14/2026
C:\Vias\VIAS_Infrastructure\Engineering - Documents\03 - Projects\PRJ23008M-NC05_SM-6105H\04-Design\SM-6105H\Signing and Delineation\Signing\SM-6105H_SGN_01.dgn
User: Matthew Douglas

CONTRACT: DE00419 T.I.P.: SM-6105H / HS-2405AH

STATE OF NORTH CAROLINA DEPARTMENT OF TRANSPORTATION

SIGNING PLAN DURHAM COUNTY

LOCATION: CONSTRUCT A SOUTHBOUND RIGHT TURN LANE
ON NC 54 (S. MIAMI BLVD.) AT
SR 1978 (HOPSON RD.)

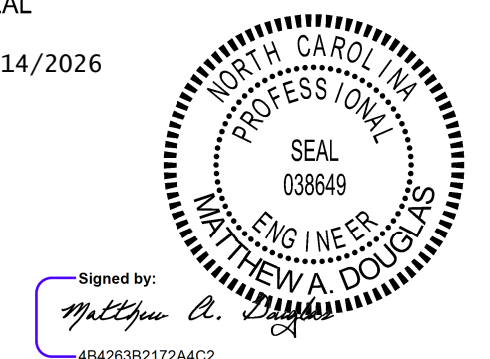
TIP NO. SM-6105H / HS-2405AH	SHEET NO. SIGN-1
APPROVED: _____	
DATE: _____	
SEAL 2/14/2026	
	
<p>Signed by: <i>Matthew A. Douglas</i></p> <p>48426382172A4C2</p>	
<p>DOCUMENT NOT CONSIDERED FINAL UNLESS ALL SIGNATURES COMPLETED</p>	

ROADWAY STANDARD DRAWING

THE FOLLOWING ROADWAY STANDARDS AS APPEAR IN "ROADWAY STANDARD DRAWINGS" - PROJECT SERVICES UNIT - N.C. DEPARTMENT OF TRANSPORTATION - RALEIGH, N.C., DATED JANUARY 2024 ARE APPLICABLE TO THIS PROJECT AND BY REFERENCE HEREBY ARE CONSIDERED A PART OF THESE PLANS:

STD. NO.	TITLE
904.10	ORIENTATION OF GROUND MOUNTED SIGNS
904.50	MOUNTING OF TYPE 'D','E', AND 'F' SIGNS ON 'U' CHANNEL SUPPORTS

GENERAL NOTES

THE FOLLOWING GENERAL NOTES APPLY AT ALL TIMES FOR THE DURATION OF THE CONSTRUCTION PROJECT, EXCEPT WHEN OTHERWISE NOTED IN THE PLAN, OR DIRECTED BY THE ENGINEER.

- A) WHEN NOT STATIONED OR DIMENSIONED ON PLANS, ALL 'E' SIGNS SHALL BE FIELD LOCATED BY THE ENGINEER
- B) ALL EXISTING SIGNS ON "U" CHANNEL POST WITHIN THE PROJECT LIMITS SHALL BE HANDLED WITH CARE AND RELOCATED TO AVOID CONFLICT WITH PROPOSED IMPROVEMENTS.
- C) CONTRACTOR TO RELOCATE EXISTING SIGNS WITH CARE. DAMAGED SIGNS TO BE REPLACED.

SUMMARY OF QUANTITIES

ITEM NO.		ITEM DESCRIPTION	QUANTITY	UNIT
DESC. NO.	SECT. NO.			
4025000000	901	CONTRACTOR FURNISHED, TYPE E SIGN	7.25	S.F.
4072000000	903	SUPPORTS, 3 LB STEEL U-CHANNEL	15	L.F.
4102000000	904	SIGN ERECTION, TYPE E	2	EA.
4116100000	904	SIGN ERECTION, RELOCATE SIGN TYPE E	1	EA.
4155000000	907	DISPOSAL OF SIGN SYSTEM, U-CHANNEL	1	EA.

INDEX

SHEET NO.	DESCRIPTION
SIGN-1	TITLE SHEET
SIGN-2	TYPE "E" SIGNS
SIGN-3	SIGN DETAIL SHEET

PLAN SUBMITTED TO: N.C.D.O.T. SIGNING AND DELINEATION UNIT	
MITCH EATON, PE	SIGNING & DELINEATION REGIONAL ENGINEER
DERRICK H. BEARD	SIGNING & DELINEATION PROJECT DESIGN ENGINEER

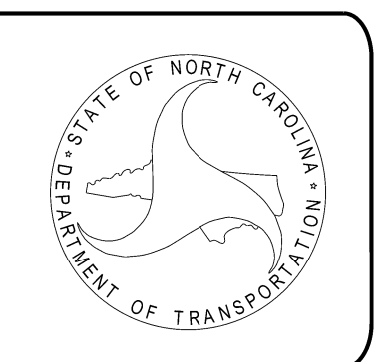

PLAN PREPARED BY:	
NICK RAMIREZ, PE	PROJECT MANAGER
MATTHEW DOUGLAS, PE	PROJECT DESIGN ENGINEER

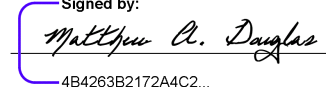

220 HORIZON DRIVE, SUITE 117
RALEIGH, NC 27615
PHONE (727) 214-7698
LICENSE NO. P-2679
WWW.VIASINFRASTRUCTURE.COM

APPROVED: 
Signed by: Matthew A. Douglas
484263821724AC2
 DATE: 12/17/2025

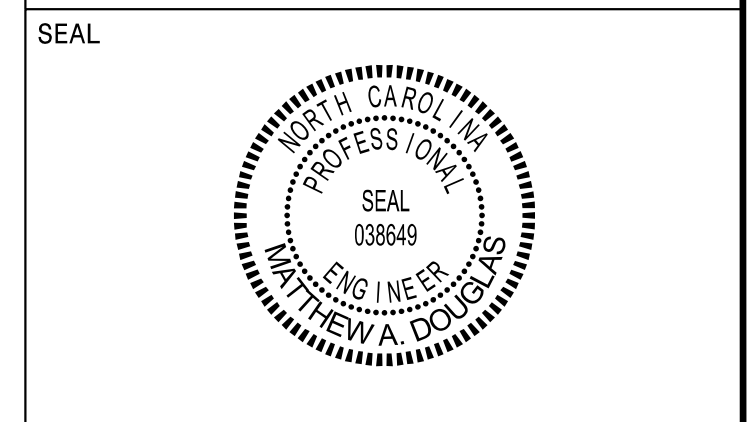

**DOCUMENT NOT CONSIDERED FINAL
UNLESS ALL SIGNATURES COMPLETED**



220 HORIZON DRIVE, SUITE 117
 RALEIGH, NC 27615
 PHONE (727) 214-7698
 LICENSE NO. P-2673
 WWW.VIASINFRASTRUCTURE.COM

401 QUANTITY REQ'D 1

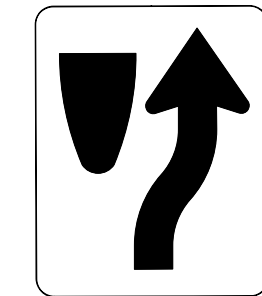

24" X 30"
R4-7

ONE "U" POST PER SIGN

402 QUANTITY REQ'D 1

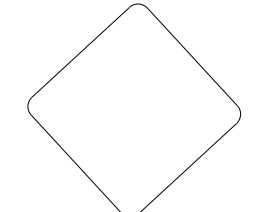

18" X 18"
OM1-3

MOUNT BELOW SIGN 401

TYPE "E" SIGNS

12/17/2025
 C:\Users\VIAS_Infrastucture\Engineering - Documents\03 - Projects\PRJ23008M-NC05_SM-6105H\04-Design\SM-6105H\Signing and Delineation\Signing\SM-6105H_SGN_02.dgn
 User: Matthew Douglas

APPROVED: _____
DATE: _____

SEAL
2/14/2026

Signed by: *Matthew A. Douglas*
484263821724AC2

**DOCUMENT NOT CONSIDERED FINAL
UNLESS ALL SIGNATURES COMPLETED**

VIAS
INFRASTRUCTURE
220 HORIZON DRIVE, SUITE 117
RALEIGH, NC 27615
PHONE (727) 214-7698
LICENSE NO. P-2673
WWW.VIASINFRASTRUCTURE.COM

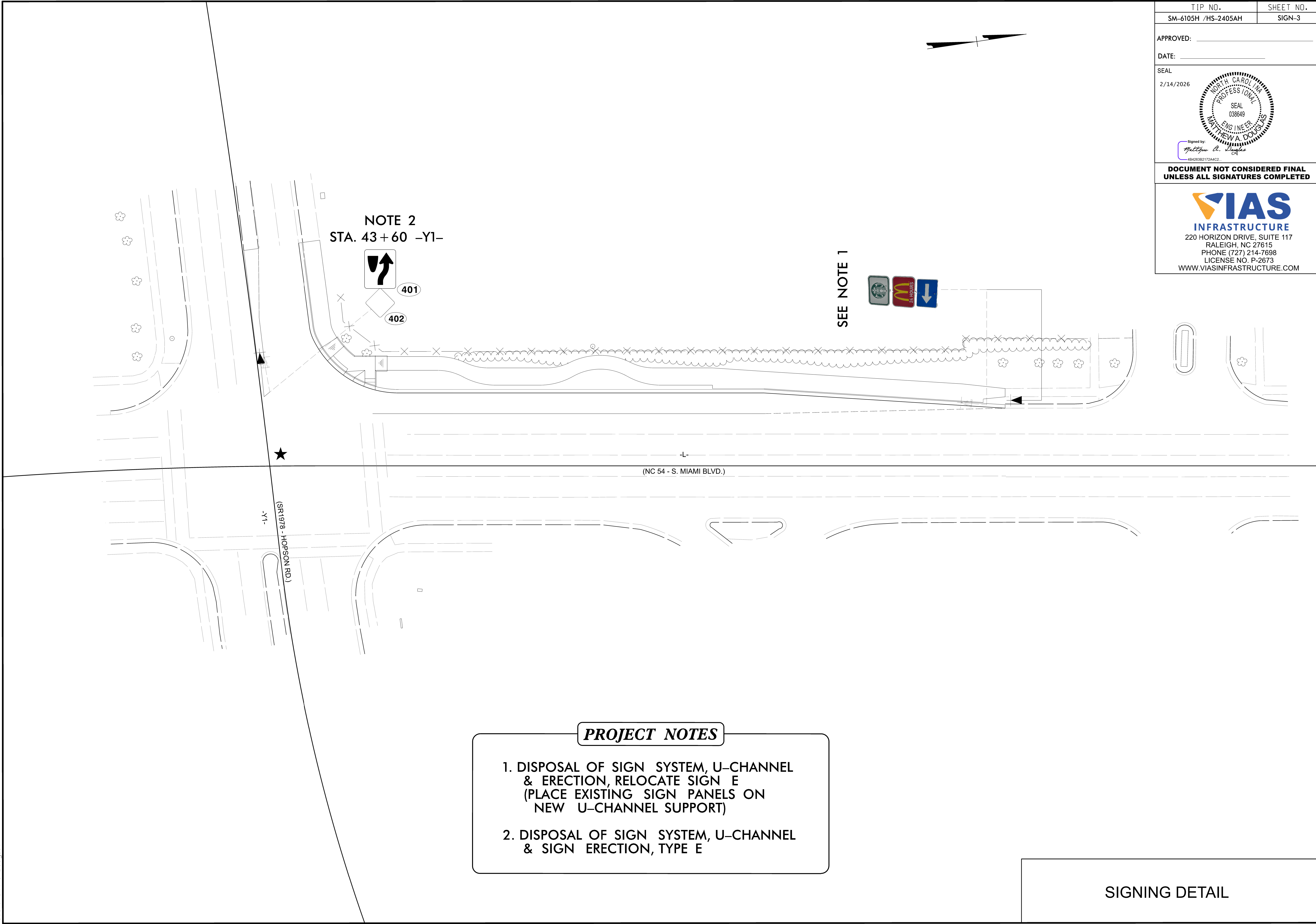

NOTE 2
STA. 43 + 60 -Y1-

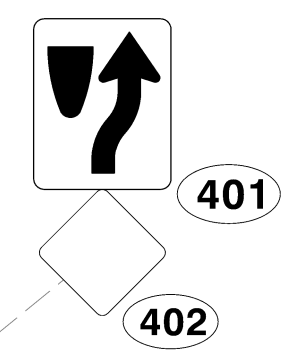

SEE NOTE 1



PROJECT NOTES

1. DISPOSAL OF SIGN SYSTEM, U-CHANNEL & ERECTION, RELOCATE SIGN E (PLACE EXISTING SIGN PANELS ON NEW U-CHANNEL SUPPORT)
2. DISPOSAL OF SIGN SYSTEM, U-CHANNEL & SIGN ERECTION, TYPE E

SIGNING DETAIL

2/14/2026
 C:\Users\VIAS\OneDrive\Engineering - Documents\03 Projects\PRJ23008V-NC05-SM-6105H\04-Design\SM-6105H\Signing and Delineation\Signing\SM-6105H_SGN_23.dgn
 User: Matthew Douglas

DEFAULT PHASING DIAGRAM

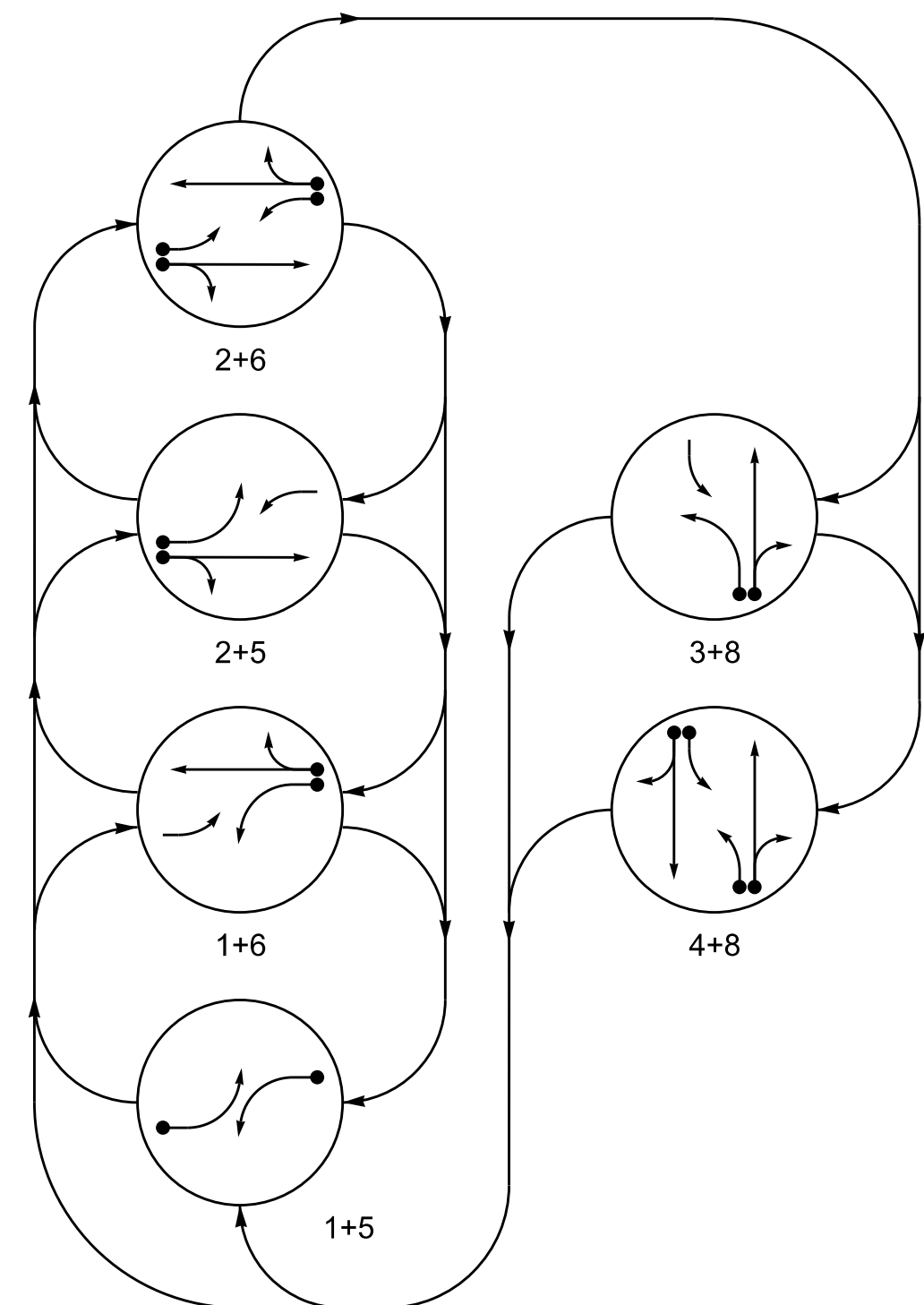

DEFAULT PHASING TABLE OF OPERATION

SIGNAL FACE	PHASE						FLASH
	1+5	1+6	2+5	2+6	3+8	4+8	
11	←	←	←	←	←	←	
21, 22	R	R	G	G	R	R	
31	←	←	←	←	←	←	
41, 42	R	R	R	R	R	G	
43	←	←	←	←	←	←	
51	←	←	←	←	←	←	
61, 62	R	G	R	G	R	R	
81, 82	R	R	R	R	G	G	

SIGNAL FACE I.D.

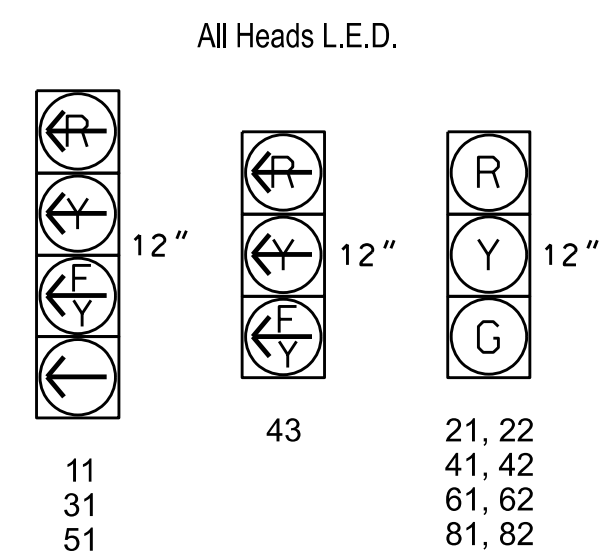

ALTERNATE PHASING DIAGRAM

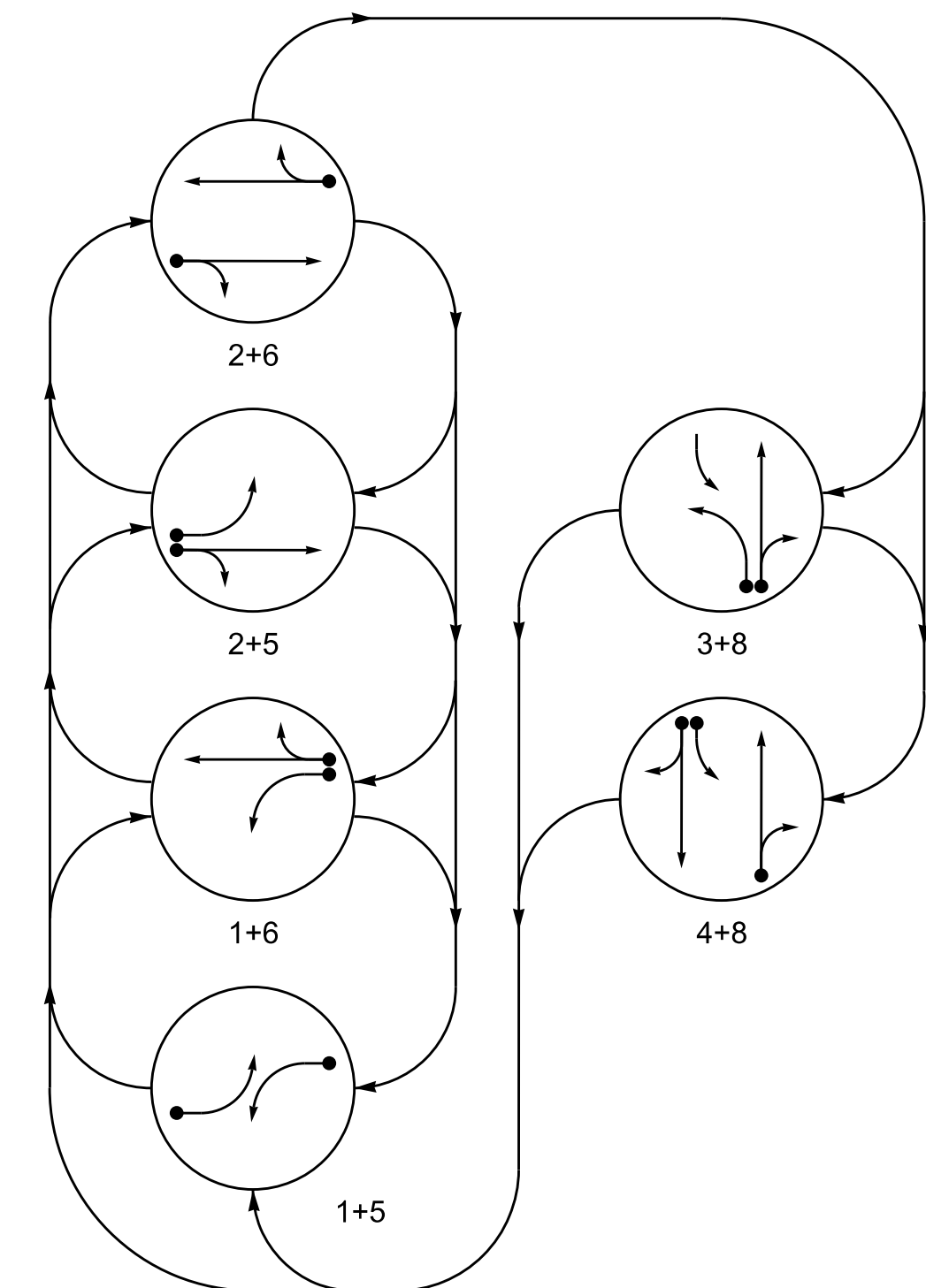

ALTERNATE PHASING TABLE OF OPERATION

SIGNAL FACE	PHASE						FLASH
	1+5	1+6	2+5	2+6	3+8	4+8	
11	←	←	←	←	←	←	
21, 22	R	R	G	G	R	R	
31	←	←	←	←	←	←	
41, 42	R	R	R	R	R	G	
43	←	←	←	←	←	←	
51	←	←	←	←	←	←	
61, 62	R	G	R	G	R	R	
81, 82	R	R	R	R	G	G	

6 Phase Fully Actuated (Isolated)

NOTES

- Refer to "Roadway Standard Drawings NCDOT" dated January 2024 and "Standard Specifications for Roads and Structures" dated January 2024.
- Do not program signal for late night flashing operation unless otherwise directed by the Engineer.
- Phase 1 and/or phase 5 may be lagged.
- Phase 3 may be lagged.
- Disconnect and abandon existing loop 6B.
- Set all detector units to presence mode.
- In the event of loop replacement, refer to the current TSMO Design Manual and submit a Plan of Record to the Signal Design Section.
- Install new controller in existing cabinet.
- Pavement markings are existing.
- The Division Traffic Engineer will determine the hours of use for each phasing plan.
- This intersection uses non-intrusive detection. Install detectors according to the manufacturer's instructions to achieve the desired detection.

PHASING DIAGRAM DETECTION LEGEND

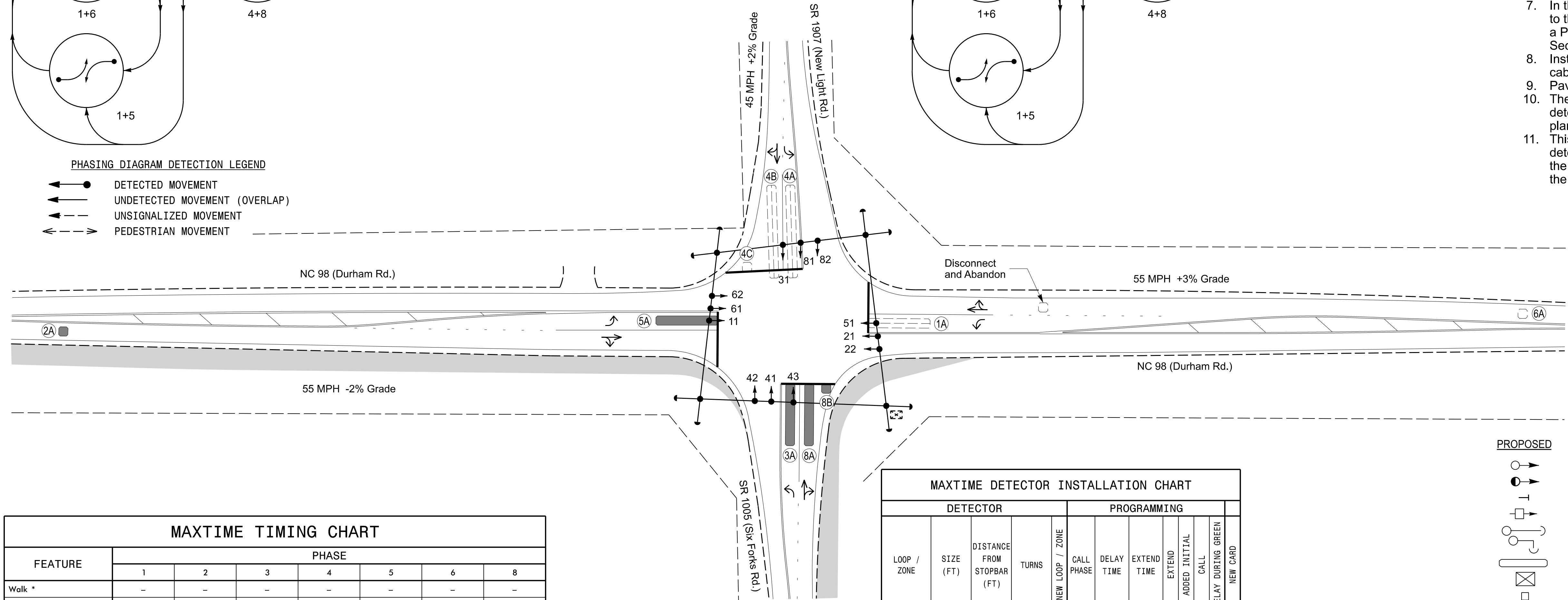
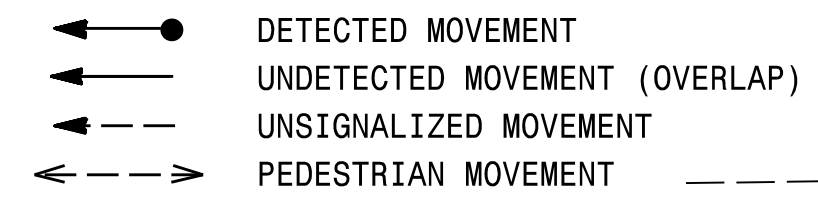

MAXTIME TIMING CHART

FEATURE	PHASE							
	1	2	3	4	5	6	7	8
Walk *	-	-	-	-	-	-	-	-
Ped Clear	-	-	-	-	-	-	-	-
Min Green *	7	14	7	7	7	14	7	7
Passage *	2.0	6.0	1.0	1.0	2.0	6.0	1.0	1.0
Max 1 *	20	75	25	25	20	75	25	25
Yellow Change	3.0	5.4	3.0	4.8	3.0	5.4	4.8	4.8
Red Clear	2.3	1.0	2.1	1.0	2.1	1.0	1.0	1.0
Added Initial *	-	2.5	-	-	-	2.5	-	-
Maximum Initial *	-	46	-	-	-	46	-	-
Time Before Reduction *	-	15	-	-	-	15	-	-
Time To Reduce *	-	30	-	-	-	30	-	-
Minimum Gap	-	3.4	-	-	-	3.4	-	-
Advance Walk	-	-	-	-	-	-	-	-
Non Lock Detector	X	-	X	X	X	-	X	X
Vehicle Recall	-	MIN RECALL	-	-	-	MIN RECALL	-	-
Dual Entry	-	-	-	X	-	-	-	X

* These values may be field adjusted. Do not adjust Min Green and Passage times for phases 2 and 6 lower than what is shown. Min Green for all other phases should not be lower than 4 seconds.

MAXTIME DETECTOR INSTALLATION CHART

LOOP / ZONE	SIZE (FT)	DISTANCE FROM STOPBAR (FT)	TURNS	NEW LOOP / ZONE	PROGRAMMING							
					CALL PHASE	DELAY TIME	EXTEND TIME	EXTEND	ADDED INITIAL	CALL	DELAY DURING GREEN	NEW CARD
1A	6X40	0	2-4-2	-	1	15.0*	-	X	-	X	-	-
2A	6X6	420	**	X	6#	3.0	-	X	-	X	X	-
3A	6X60	0	**	X	3	15.0*	-	X	-	X	-	**
4A	6X60	+5	2-4-2	-	4	3.0	-	X	-	X	-	-
4B	6X60	+5	2-4-2	-	4	10.0	-	X	-	X	-	-
4C	6X6	0	EXIST	-	4	15.0	-	X	-	X	-	-
5A	6X40	0	**	X	5	15.0*	-	X	-	X	-	**
6A	6X6	420	EXIST	-	6	-	-	X	X	X	-	-
6B	6X6	110	EXIST	-	-	-	-	-	-	-	-	-
8A	6X60	0	**	X	8	10.0	-	X	-	X	-	**
8B	6X6	0	**	X	8	15.0	-	X	-	X	-	**

* Reduce Delay to 3 seconds during Alternate Phasing Operation.
 # Disable phase call for loop during Alternate Phasing Operation.
 ** Non-intrusive detection zone.

LEGEND

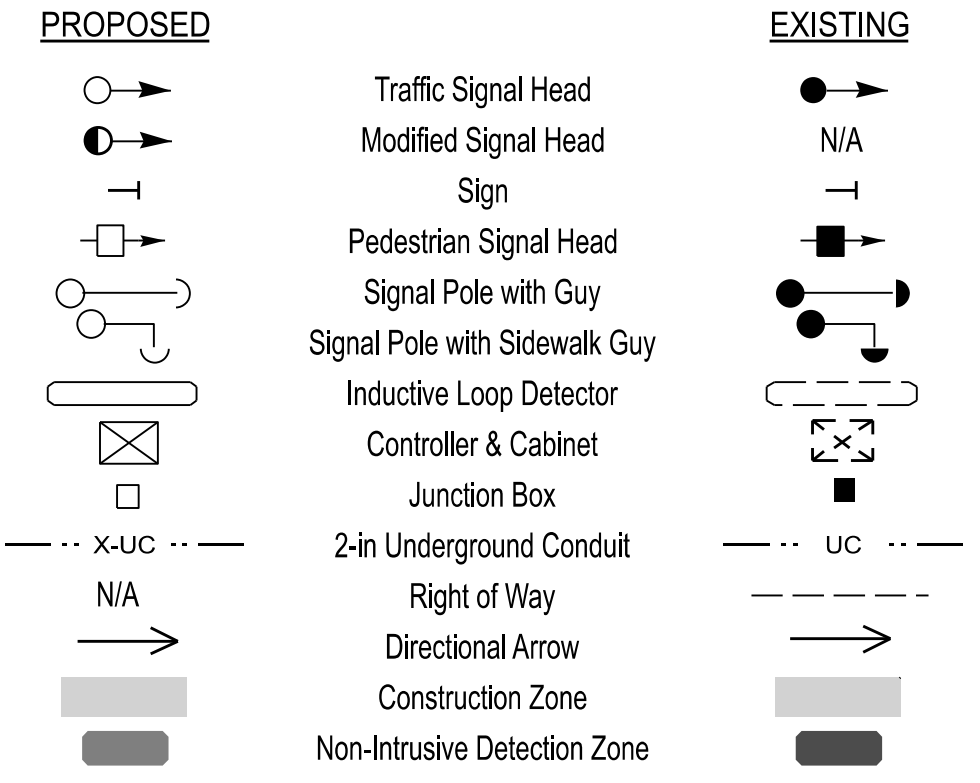

Signal Upgrade - Temporary Design

Prepared in the Offices of:

NC 98 (Durham Road)
at
SR 1005 (Six Forks Road) and
SR 1907 (New Light Road)
 Wake County Wake Forest

Division 5

PLAN DATE: March 2025 REVIEWED BY:

PREPARED BY: J.A. Lohr REVIEWED BY:

DOCUMENT NOT CONSIDERED FINAL UNLESS ALL SIGNATURES COMPLETED

SEAL

ROBERT J. ZIEMBA

PROFESSIONAL ENGINEER

05/01/2025

DATE

SIG. INVENTORY NO. 05-1331T

I:\MX\2025\0545 - 1331T\Signal Design\2025-0515\1331T_sgl_dwg_2025mod.dgn
 11/19/2025 10:56:45 AM
 J:\MX\2025\0545 - 1331T\Signal Design\2025-0515\1331T_sgl_dwg_2025mod.dgn

16 CHANNEL CONFLICT MONITOR PROGRAMMING DETAIL

(remove jumpers and set switches as shown)

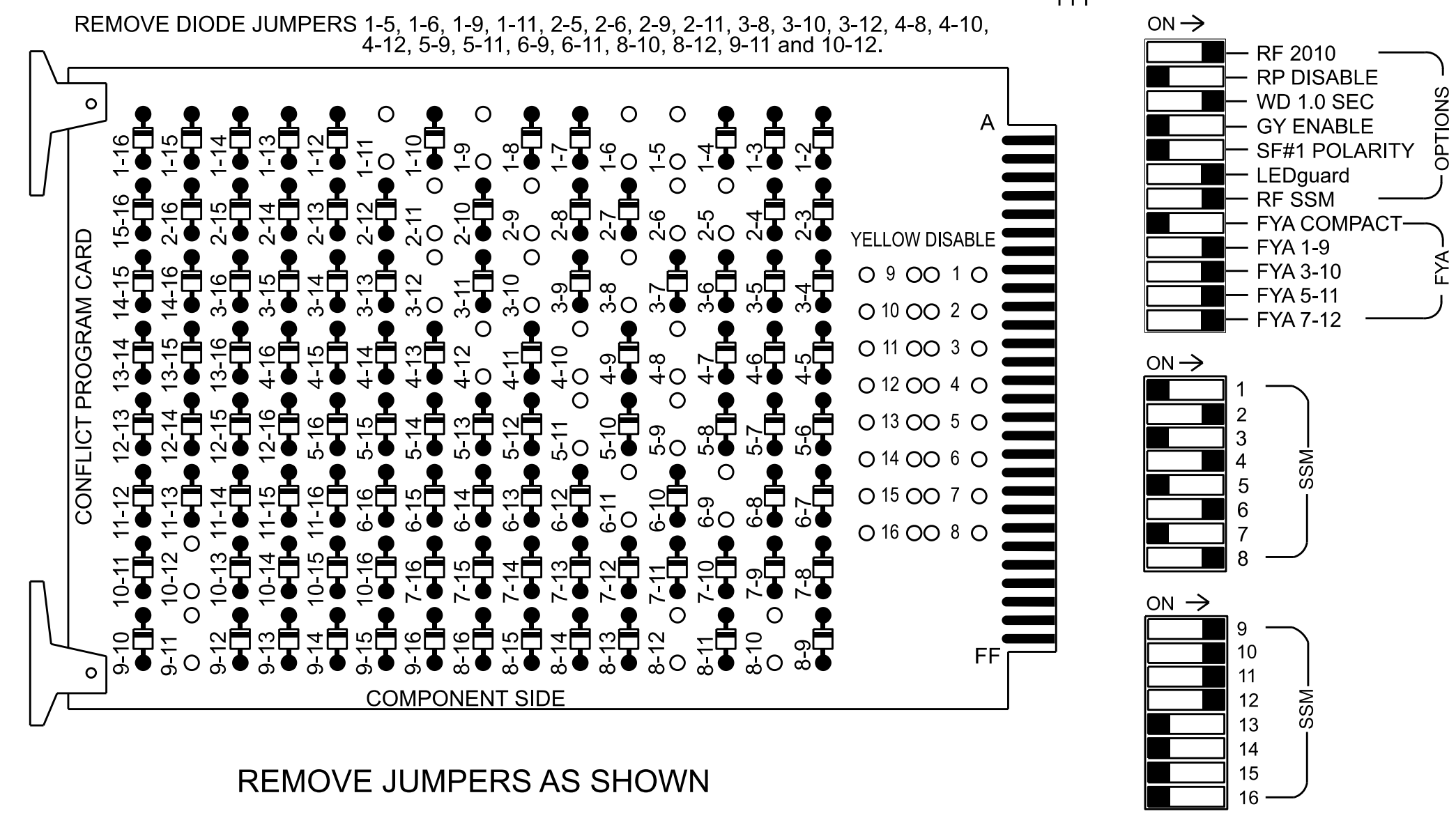

- REMOVE DIODE JUMPERS 1-5, 1-6, 1-9, 1-11, 2-5, 2-6, 2-9, 2-11, 3-8, 3-10, 3-12, 4-8, 4-10, 4-12, 5-9, 5-11, 6-9, 6-11, 8-10, 8-12, 9-11 and 10-12.
- REMOVE JUMPERS AS SHOWN
- NOTES:
 1. Card is provided with all diode jumpers in place. Removal of any jumper allows its channels to run concurrently.
 2. Make sure jumpers SEL2-SEL5 are present on the monitor board.

NOTES

- To prevent "flash-conflict" problems, insert red flash program blocks for all vehicle load switches in the output file. The installer shall verify that signal heads flash in accordance with the signal plan.
- Program phases 4 and 8 for Dual Entry.
- Program controller to start up in phase 2 Green No Walk and 6 Green No Walk.
- If this signal will be managed by an ATMS software, enable controller and detector logging for all detectors used at this location.

EQUIPMENT INFORMATION

Controller.....2070LX
 Cabinet.....332 w/ Aux
 Software.....Q-Free MAXTIME
 Cabinet Mount.....Base
 Output File Positions.....18 With Aux. Output File
 Load Switches Used.....S1, S2, S3, S4, S5, S6, S8, S9, S10, S12, S13
 Phases Used.....1, 2, 3, 4, 5, 6, 8
 Overlap "1".....*
 Overlap "2".....*
 Overlap "3".....*
 Overlap "4".....*
 *See overlap programming detail on sheet 2

SIGNAL HEAD HOOK-UP CHART

LOAD SWITCH NO.	S1	S2	S2P	S3	S4	S4P	S5	S6	S6P	S7	S8	S8P	S9	S10	S11	S12	S13	S14
CMU CHANNEL NO.	1	2	13	3	4	14	5	6	15	7	8	16	9	10	17	11	12	18
PHASE	1	2	2 PED	3	4	4 PED	5	6	6 PED	7	8	8 PED	OL1	OL2	SPARE	OL3	OL4	SPARE
SIGNAL HEAD NO.	11*	21,22	NU	31*	41,42	NU	51*	61,62	NU	NU	81,82	NU	11*	31*	NU	51*	43*	NU
RED		128			101			134			107							
YELLOW	*	129		*	102		*	135			108							
GREEN		130			103			136			109							
RED ARROW													A121	A124		A114	A101	
YELLOW ARROW													A122	A125		A115	A102	
FLASHING YELLOW ARROW													A123	A126		A116	A103	
GREEN ARROW	127			118			133											

NU = Not Used
 * Denotes install load resistor. See load resistor installation detail this sheet.
 * See pictorial of head wiring in detail this sheet.

INPUT FILE POSITION LAYOUT

(front view)

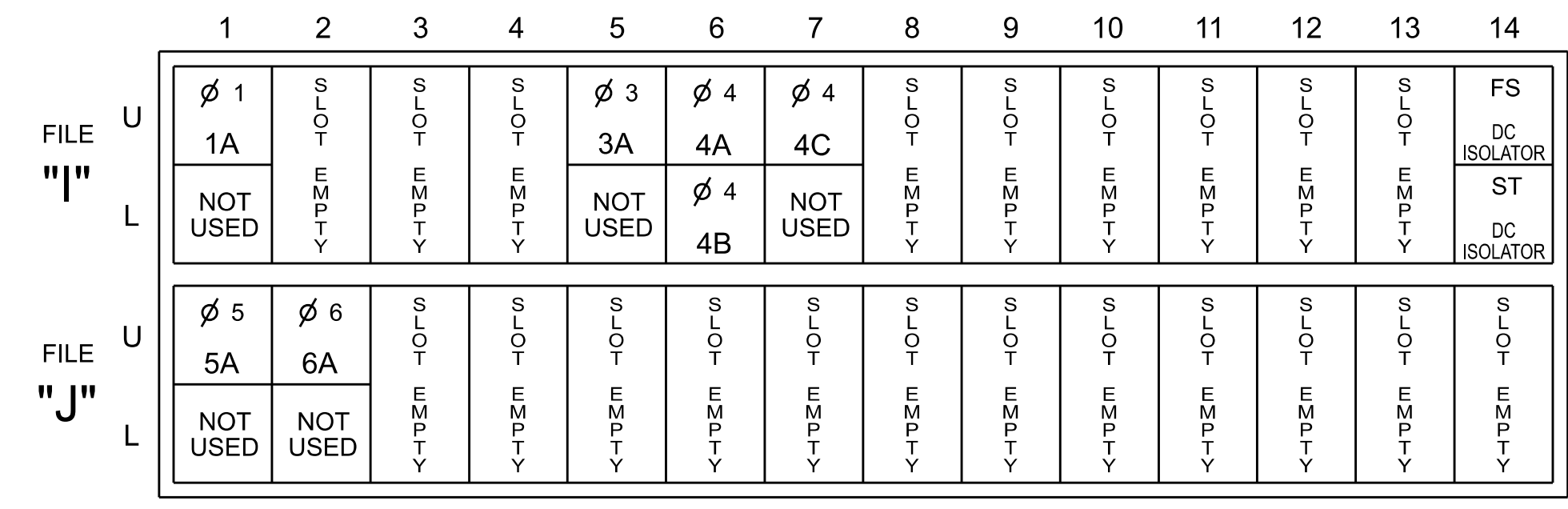

EX. : 1A, 2A, ETC. = LOOP NO.'S
 FS = FLASH SENSE
 ST = STOP TIME

! If present, remove jumpers from I1-W to J4-W, I5-W to J8-W, and J1-W to I4-W on rear of input file.

INPUT FILE CONNECTION & PROGRAMMING CHART

LOOP NO.	LOOP TERMINAL	INPUT FILE POS.	PIN NO.	INPUT POINT	DETECTOR NO.	CALL PHASE	DELAY TIME	EXTEND TIME	EXTEND	ADDED INITIAL	CALL	DELAY DURING GREEN
1A	TB2-1,2	I1U	56	18	1 *	1	15.0		X		X	
				-	29 *	6	3.0		X		X	X
3A	TB4-5,6	I5U	58	20	7 *	3	15.0		X		X	
				-	30 *	8	3.0		X		X	
4A	TB4-9,10	I6U	41	3	8	4	3.0		X		X	
4B	TB4-11,12	I6L	45	7	9	4	10.0		X		X	
4C	TB6-1,2	I7U	65	31	10	4	15.0		X		X	
5A	TB3-1,2	J1U	55	17	15 *	5	15.0		X		X	
				-	31 *	2	3.0		X		X	X
6A	TB3-5,6	J2U	40	2	16	6			X	X	X	

* For the detectors to work as shown on the signal plan see the Detector Programming Detail for Alternate Phasing on Sheet 2 of this plan.

INPUT FILE POSITION LEGEND: J2L

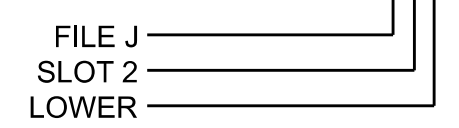

FYA SIGNAL WIRING DETAIL

(wire signal heads as shown)

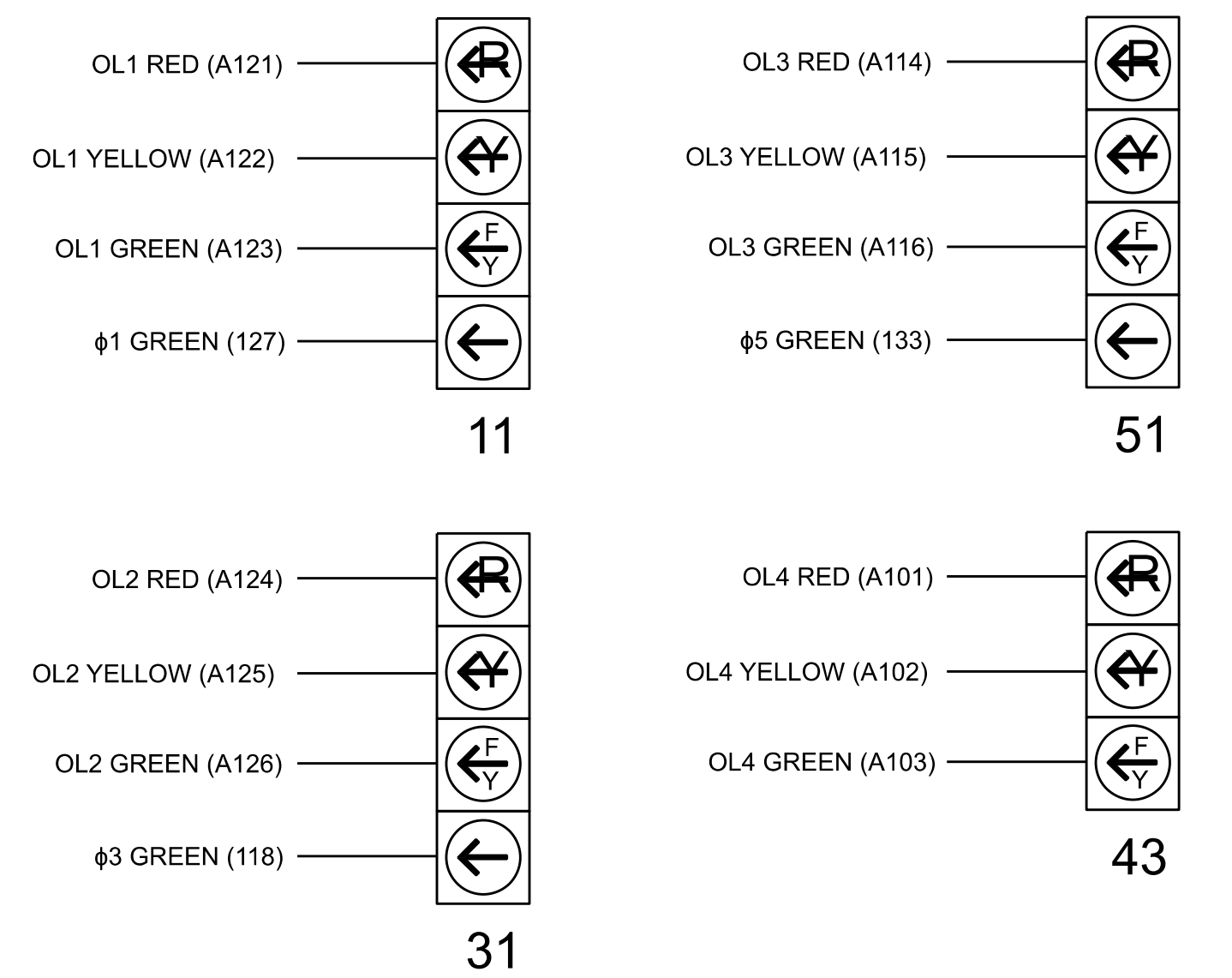

LOAD RESISTOR INSTALLATION DETAIL

(install resistors as shown)

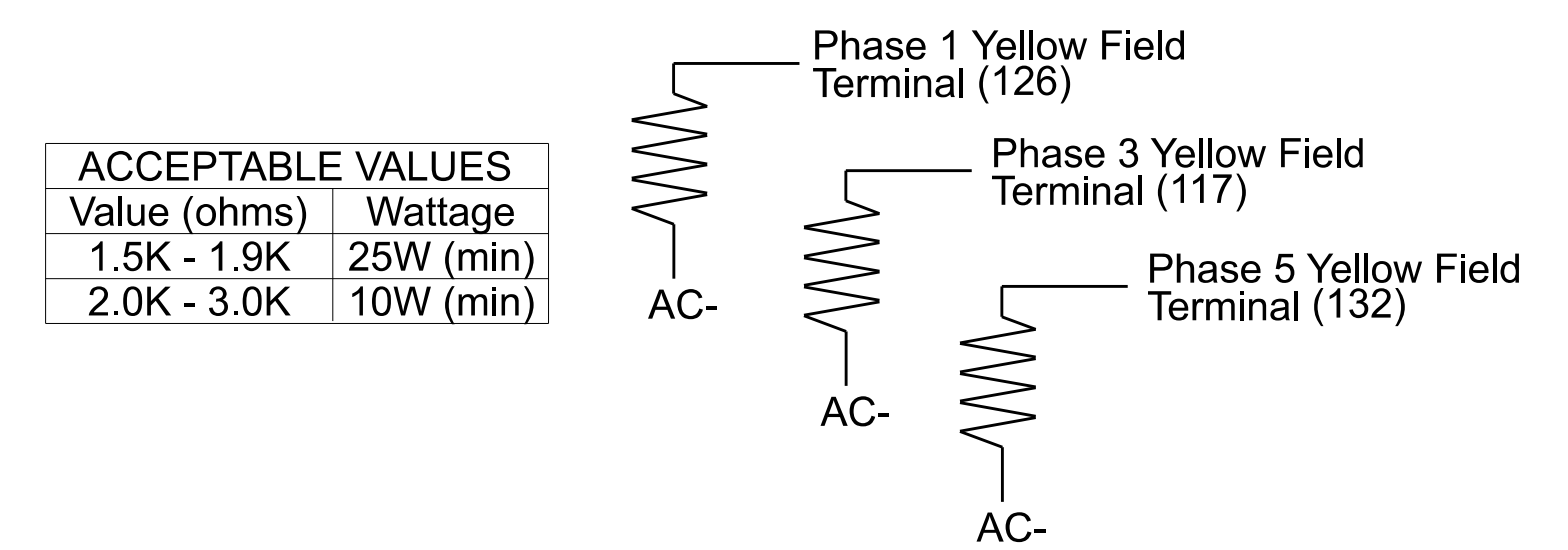

SPECIAL DETECTOR NOTE

Install a non-intrusive detection system for vehicle detection. Perform installation according to manufacturer's directions and NCDOT engineer -approved mounting locations to accomplish the detection schemes shown on the Signal Design Plans.

For detection zones 3A and 5A, detector card placements are typical for a NCDOT installation. Inputs associated with these slots are compatible with the time of day instructions located on sheet 2 of this electrical detail.

THIS ELECTRICAL DETAIL IS FOR THE SIGNAL DESIGN: 05-1331T
 DESIGNED: March 2025
 SEALED: 05/01/2025
 REVISED: N/A

Electrical Detail - Sheet 1 of 2

Prepared in the Offices of:
 Transportation Mobility and Safety Division
 STATE OF NORTH CAROLINA
 DEPARTMENT OF TRANSPORTATION
 Signal Management Section

750 N. Greenfield Pkwy, Garner, NC 27529

DOCUMENT NOT CONSIDERED FINAL UNLESS ALL SIGNATURES COMPLETED

SEAL
 NORTH CAROLINA PROFESSIONAL ENGINEER
 RYAN W. HOUGH
 SEAL 036833

NC 98 (Durham Road) at SR 1005 (Six Forks Road) and SR 1907 (New Light Road)

Division 5 Wake County Wake Forest

PLAN DATE: April 2025 REVIEWED BY:
 PREPARED BY: Sarah Kirkpatrick REVIEWED BY:
 REVISIONS INIT. DATE

Signed by: Ryan W. Hough 05/01/2025
 DATE: 05/01/2025
 SEAL 430320FAA2054G3
 SIG. INVENTORY NO. 05-1331T

I:\MY-2025-13114
 p:\ncdot-pw\benf\ey.com\ncdot-pw\01\Documents\NCDOT-TSMO\Signal-Design-Sect1-ar\01\vision_05-05-1331\Signal-Management\051331T_sm.eia_20250501.dgn
 sgm.r.pattick

MAXTIME ALTERNATE PHASING ACTIVATION DETAIL

To run alternate phasing, select a Pattern that is programmed to run Overlap Plan 2 and Detector Plan 2. A Pattern can be selected through the scheduler or manually by changing the Operational Mode.

PHASING	OVERLAP PLAN	VEH DET PLAN
ACTIVE PLAN REQUIRED TO RUN DEFAULT PHASING	1	1
ACTIVE PLAN REQUIRED TO RUN ALTERNATE PHASING	2	2

ALTERNATE PHASING CHANGE SUMMARY

THE FOLLOWING IS A SUMMARY OF WHAT TAKES PLACE WHEN OVERLAP PLAN 2 AND VEHICLE DETECTOR PLAN 2 ACTIVATE TO CALL THE "ALTERNATE PHASING":

OVERLAP PLAN 2: Modifies overlap included phases for heads 11, 31 and 51 to run protected turns only.

VEH DET PLAN 2: Disables phase 6 call on loop 1A and reduces delay time for phase 1 call on loop 1A to 3 seconds.

Disables phase 8 call on loop 3A and reduces delay time for phase 3 call on loop 3A to 3 seconds.

Disables phase 2 call on loop 5A and reduces delay time for phase 5 call on loop 5A to 3 seconds.

OUTPUT CHANNEL CONFIGURATION

Front Panel
Main Menu >Controller >More>Channels>Channels Config

Web Interface
Home >Controller >Advanced IO>Channels>Channel Configuration

Channel Configuration

Channel	Control Type	Control Source	Flash Yellow	Flash Red	Flash Alt	MMU Channel
1	Phase Vehicle	1		X	X	1
2	Phase Vehicle	2		X		2
3	Phase Vehicle	3		X	X	3
4	Phase Vehicle	4		X		4
5	Phase Vehicle	5		X		5
6	Phase Vehicle	6		X	X	6
7	Phase Vehicle	7		X		7
8	Phase Vehicle	8		X	X	8
9	Overlap	1		X	X	9
10	Overlap	2		X	X	10
11	Overlap	3		X		11
12	Overlap	4		X		12
13	Phase Ped	2				13
14	Phase Ped	4				14
15	Phase Ped	6				15
16	Phase Ped	8				16
17	Overlap	5		X	X	17
18	Overlap	6		X		18

THIS ELECTRICAL DETAIL IS FOR THE SIGNAL DESIGN: 05-1331T
DESIGNED: March 2025
SEALED: 05/01/2025
REVISED: N/A

MAXTIME OVERLAP PROGRAMMING DETAIL FOR DEFAULT PHASING

Front Panel
Main Menu >Controller >Overlap >Overlap Parameters/Overlap Timings

Web Interface
Home >Controller >Overlap Configuration >Overlaps

Overlap Plan 1

Overlap	1	2	3	4
Type	FYA 4 - Section	FYA 4 - Section	FYA 4 - Section	FYA 4 - Section
Included Phases	2	4	6	8
Modifier Phases	1	3	5	-
Modifier Overlaps	-	-	-	-
Trail Green	0	0	0	0
Trail Yellow	0.0	0.0	0.0	0.0
Trail Red	0.0	0.0	0.0	0.0

MAXTIME ALTERNATE PHASING PATTERN PROGRAMMING DETAIL

Front Panel
Main Menu >Controller >Coordination >Patterns

Web Interface
Home >Controller >Coordination >Patterns

Pattern Parameters

Pattern	Veh Det Plan	Overlap Plan
*	2	2

*The Pattern number(s) are to be determined by the Division and/or City Traffic Engineer.

MAXTIME STARTUP AND SOFTWARE FLASH PROGRAMMING DETAIL

Front Panel
Main Menu >Controller >Unit

Web Interface
Home >Controller >Unit

Modify parameters as shown below and save changes.

Start Up Parameters

StartUp Clearance Hold
6

Unit Flash Parameters

All Red Flash Exit Time
6

FLASHER CIRCUIT MODIFICATION DETAIL

IN ORDER TO INSURE THAT SIGNALS FLASH CONCURRENTLY ON THE SAME APPROACH, MAKE THE FOLLOWING FLASHER CIRCUIT CHANGES:

- ON REAR OF PDA - REMOVE WIRE FROM TERM. T2-4 AND TERMINATE ON T2-2.
- ON REAR OF PDA - REMOVE WIRE FROM TERM. T2-5 AND TERMINATE ON T2-3.
- REMOVE FLASHER UNIT 2.

THE CHANGES LISTED ABOVE TIES ALL PHASES AND OVERLAPS TO FLASHER UNIT 1.

MAXTIME OVERLAP PROGRAMMING DETAIL FOR ALTERNATE PHASING

Front Panel
Main Menu >Controller >Overlap >Overlap Parameters/Overlap Timings

Web Interface
Home >Controller >Overlap Configuration >Overlaps

In the table view of the web interface, right click on "Overlap" in the top left corner of the table. Copy the entire contents of Overlap Plan 1. Paste Overlap Plan 1 into Overlap Plan 2. Modify Overlap Plan 2 as shown below and save changes.

Overlap Plan 2

Overlap	1	2	3	4
Type	FYA 4 - Section	FYA 4 - Section	FYA 4 - Section	FYA 4 - Section
Included Phases	-	-	-	8
Modifier Phases	1	3	5	-
Modifier Overlaps	-	-	-	-
Trail Green	0	0	0	0
Trail Yellow	0.0	0.0	0.0	0.0
Trail Red	0.0	0.0	0.0	0.0

← NOTICE INCLUDED PHASE

MAXTIME DETECTOR PROGRAMMING DETAIL FOR ALTERNATE PHASING LOOPS 1A, 3A & 5A

Front Panel
Main Menu >Controller >Detector >Veh Det Plans

Web Interface
Home >Controller >Detector Configuration >Vehicle Detectors

In the table view of web interface right click on "Detector" in the top left corner of the table. Copy the entire contents of Detector Plan 1. Paste Detector Plan 1 into Detector Plan 2. Modify Detector Plan 2 as shown below and save changes.

Plan	Detector		
	Detector	Call Phase	Delay
1A	1	1	3.0
	29	0	3.0
3A	7	3	3.0
	30	0	3.0
5A	15	5	3.0
	31	0	3.0

Electrical Detail - Sheet 2 of 2

Prepared in the Offices of:  750 N. Greenfield Pkwy, Garner, NC 27529	NC 98 (Durham Road) at SR 1005 (Six Forks Road) and SR 1907 (New Light Road)		SEAL NORTH CAROLINA PROFESSIONAL ENGINEER RYAN W. HOUGH 036833
	Division 5 PLAN DATE: April 2025 PREPARED BY: Sarah Kirkpatrick	Wake County REVIEWED BY: REVIEWED BY:	
REVISIONS			DATE
INIT.			DATE
SIGNED BY: Ryan W. Hough			DATE: 05/01/2025
PROJECT NO. 05-1331T			SHEET NO. Sig.1.2

DEFAULT PHASING DIAGRAM

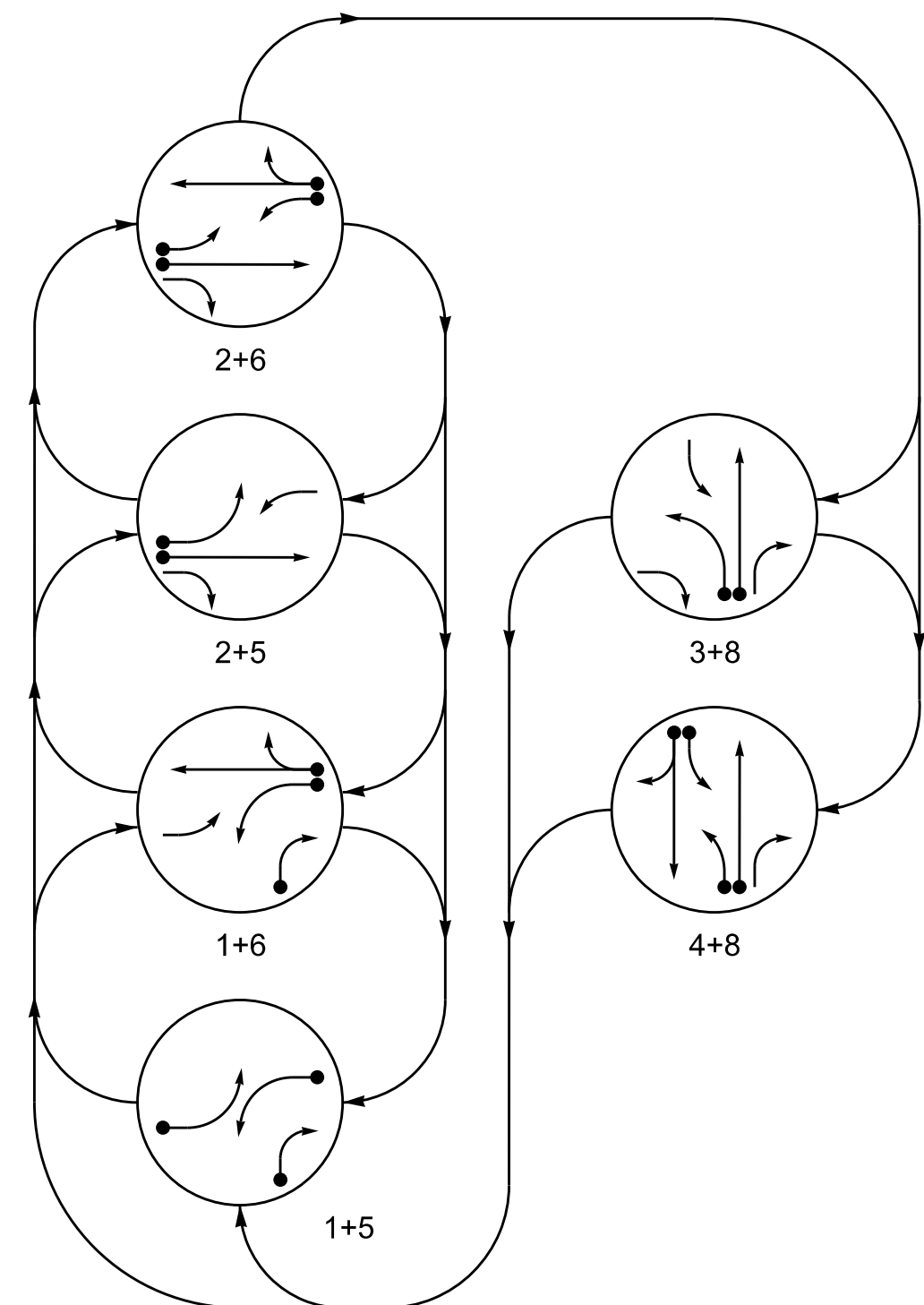

SIGNAL FACE	PHASE							
	1+5	1+6	2+5	2+6	3+8	4+8	F	H
11	←	←	←	←	←	←	←	←
21	R	R	G	G	R	R	R	R
22	R	R	G	G	R	R	R	R
31	←	←	←	←	←	←	←	←
41, 42	R	R	R	R	R	G	R	R
43	←	←	←	←	←	←	←	←
51	←	←	←	←	←	←	←	←
61, 62	R	G	R	G	R	R	R	R
81	R	R	R	R	G	G	R	R
82	R	R	R	R	G	G	R	R

ALTERNATE PHASING DIAGRAM

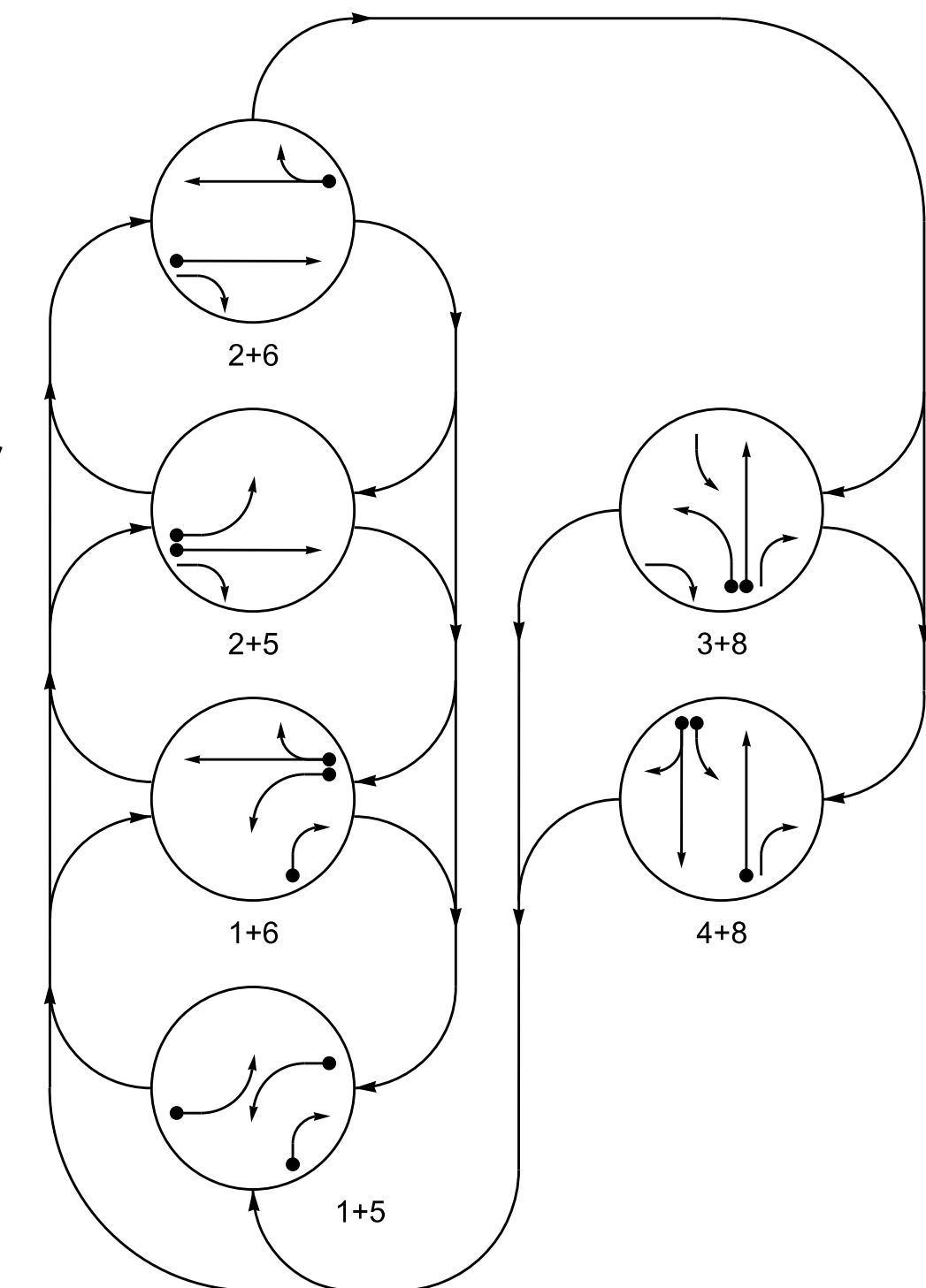

SIGNAL FACE	PHASE							
	1+5	1+6	2+5	2+6	3+8	4+8	F	H
11	←	←	←	←	←	←	←	←
21	R	R	G	G	R	R	R	R
22	R	R	G	G	R	R	R	R
31	←	←	←	←	←	←	←	←
41, 42	R	R	R	R	R	G	R	R
43	←	←	←	←	←	←	←	←
51	←	←	←	←	←	←	←	←
61, 62	R	G	R	G	R	R	R	R
81	R	R	R	R	G	G	R	R
82	R	R	R	R	G	G	R	R

SIGNAL FACE I.D.

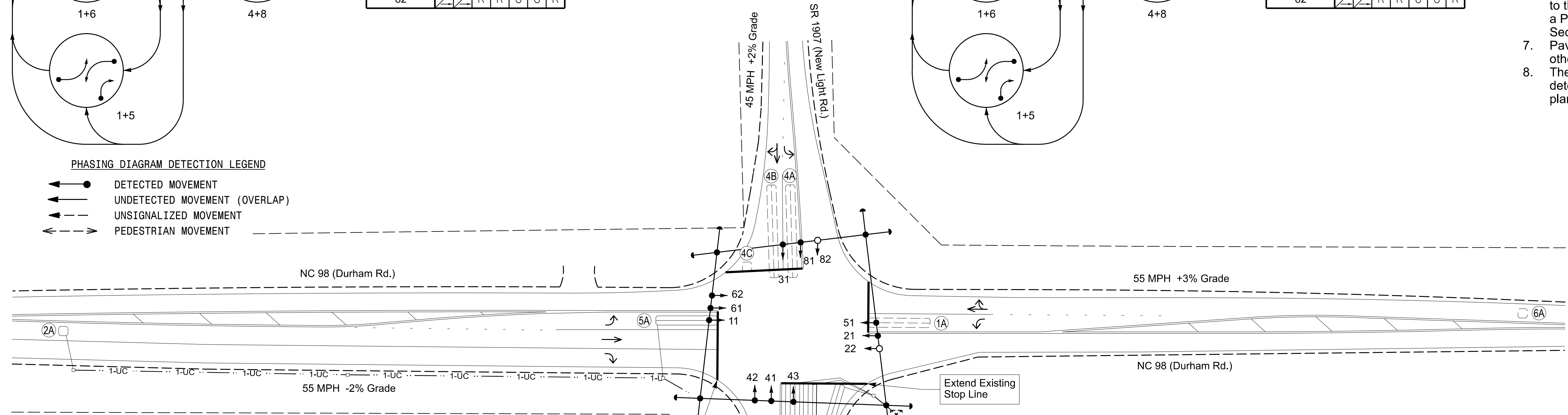
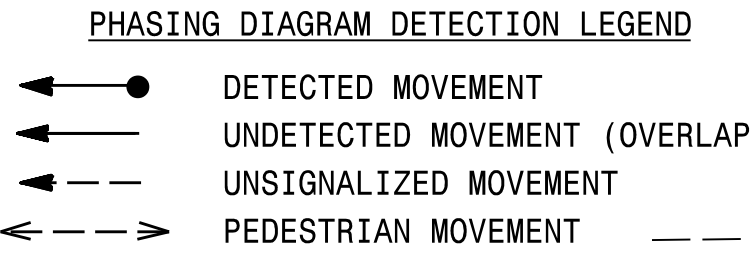
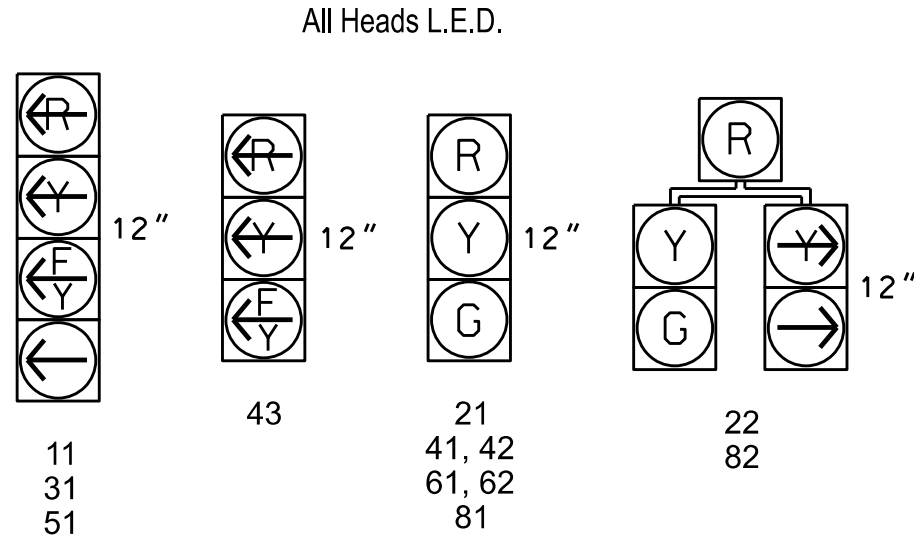

FEATURE	PHASE							
	1	2	3	4	5	6	7	8
Walk *	-	-	-	-	-	-	-	-
Ped Clear	-	-	-	-	-	-	-	-
Min Green *	7	14	7	7	7	14	7	7
Passage *	2.0	6.0	1.0	1.0	2.0	6.0	1.0	1.0
Max 1 *	20	75	25	25	20	75	25	25
Yellow Change	3.0	5.4	3.0	4.8	3.0	5.4	4.8	4.8
Red Clear	2.4	1.0	2.1	1.0	2.1	1.0	1.0	1.0
Added Initial *	-	2.5	-	-	-	2.5	-	-
Maximum Initial *	-	46	-	-	-	46	-	-
Time Before Reduction *	-	15	-	-	-	15	-	-
Time To Reduce *	-	30	-	-	-	30	-	-
Minimum Gap	-	3.4	-	-	-	3.4	-	-
Advance Walk	-	-	-	-	-	-	-	-
Non Lock Detector	X	-	X	X	X	-	-	X
Vehicle Recall	-	MIN RECALL	-	-	-	MIN RECALL	-	-
Dual Entry	-	-	-	X	-	-	-	X

* These values may be field adjusted. Do not adjust Min Green and Passage times for phases 2 and 6 lower than what is shown. Min Green for all other phases should not be lower than 4 seconds.

LOOP	SIZE (FT)	DISTANCE FROM STOPBAR (FT)	TURNS	NEW LOOP	PROGRAMMING							
					CALL PHASE	DELAY TIME	EXTEND TIME	EXTEND	ADDED INITIAL	CALL	DELAY DURING GREEN	NEW CARD
1A	6X40	0	2-4-2	-	1	15.0*	-	X	-	X	-	-
1B	6X40	0	2-4-2	X	1	15.0	-	X	-	X	-	-
2A	6X6	420	5	X	2	-	-	X	X	X	-	-
3A	6X60	0	2-4-2	X	3	15.0*	-	X	-	X	-	-
4A	6X60	+5	2-4-2	-	4	3.0	-	X	-	X	-	-
4B	6X60	+5	2-4-2	-	4	10.0	-	X	-	X	-	-
4C	6X6	0	EXIST	-	4	15.0	-	X	-	X	-	-
5A	6X40	0	2-4-2	X	5	15.0*	-	X	-	X	-	-
6A	6X6	420	EXIST	-	6	3.0	-	X	-	X	X	-
8A	6X60	0	2-4-2	X	8	10.0	-	X	-	X	-	-

* Reduce Delay to 3 seconds during Alternate Phasing Operation.
Disable phase call for loop during Alternate Phasing Operation.

6 Phase Fully Actuated (Isolated)

NOTES

- Refer to "Roadway Standard Drawings NCDOT" dated January 2024 and "Standard Specifications for Roads and Structures" dated January 2024.
- Do not program signal for late night flashing unless otherwise directed by the Engineer.
- Phase 1 and/or phase 5 may be lagged.
- Phase 3 may be lagged.
- Set all detector units to presence mode.
- In the event of loop replacement, refer to the current TSMO Design Manual and submit a Plan of Record to the Signal Design Section.
- Pavement markings are existing unless otherwise shown.
- The Division Traffic Engineer will determine the hours of use for each phasing plan.

LEGEND

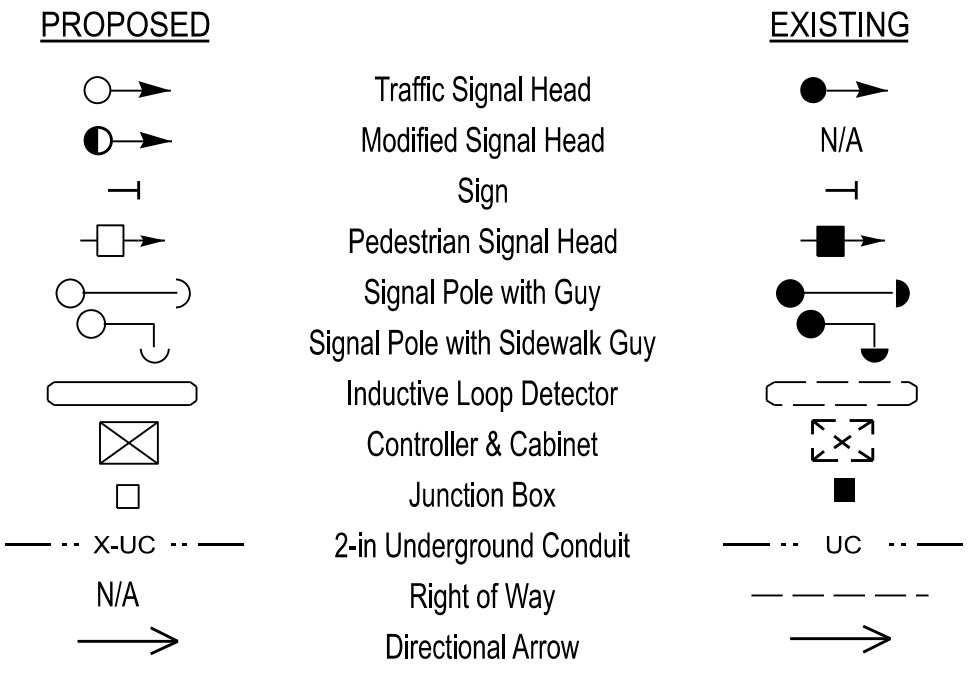

Signal Upgrade - Final Design

Prepared in the Offices of:

NC 98 (Durham Road) at SR 1005 (Six Forks Road) and SR 1907 (New Light Road)
 Division 5 Wake County Wake Forest
 PLAN DATE: March 2025 REVIEWED BY:
 PREPARED BY: J.A. Lohr REVIEWED BY:
 REVISIONS: INIT. DATE
 SCALE: 1"=40'
 0 40
 1"=40'
 DOCUMENT NOT CONSIDERED FINAL UNLESS ALL SIGNATURES COMPLETED
 SEAL
 NORTH CAROLINA PROFESSIONAL ENGINEER
 ROBERT J. ZEMBA
 05/01/2025
 SIG. INVENTORY NO. 05-1331

I:\MX\2025\0563\1005\1005_Sig\1005_Sig_Signal_Design\1005_Sig_Signal_Design\1005_Sig_Signal_Design\1005_Sig_Signal_Design.dgn
 05/01/2025 05:53
 J:\MX\2025\0563\1005\1005_Sig\1005_Sig_Signal_Design\1005_Sig_Signal_Design\1005_Sig_Signal_Design.dgn

16 CHANNEL CONFLICT MONITOR PROGRAMMING DETAIL

(remove jumpers and set switches as shown)

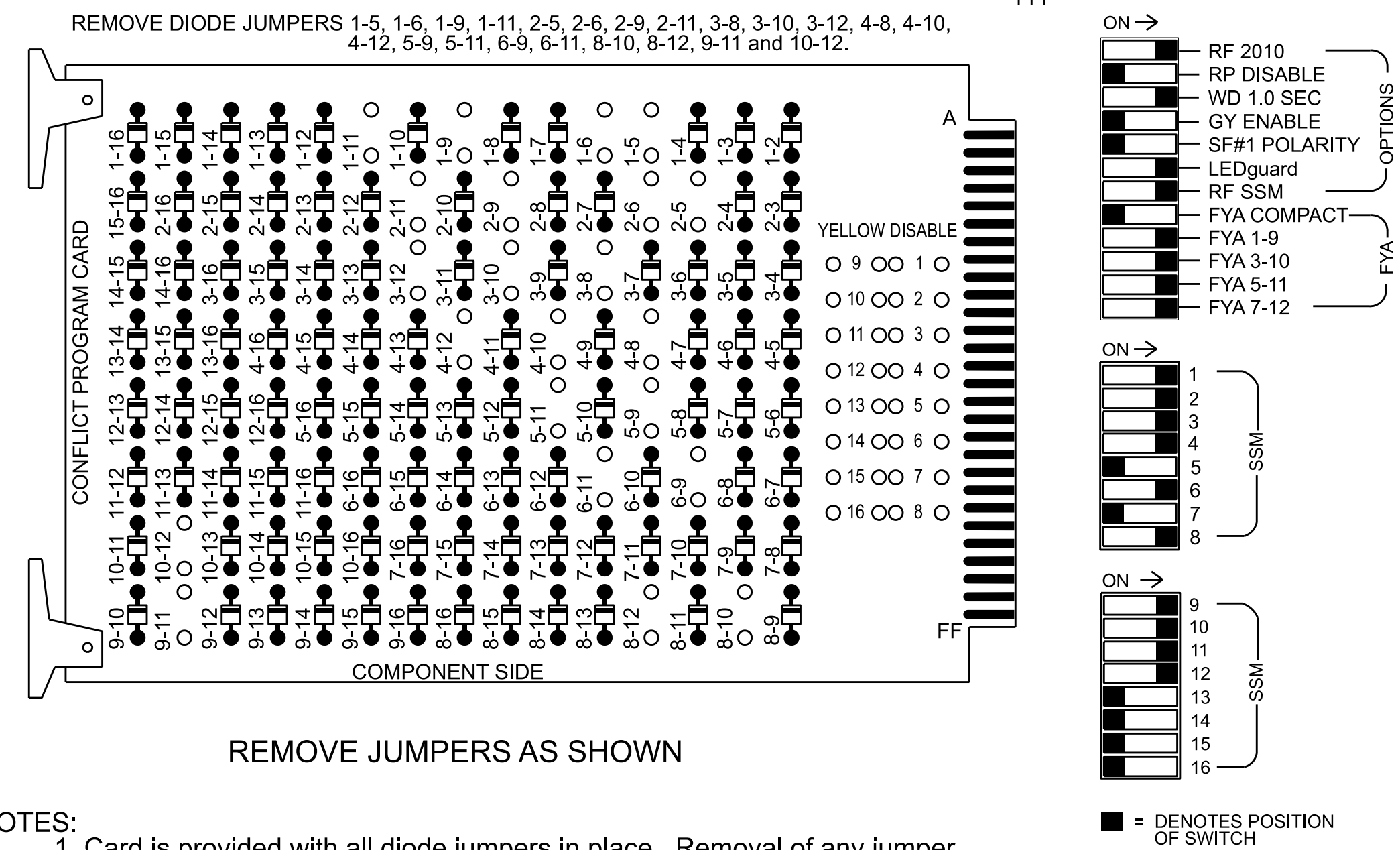

- NOTES:
- Card is provided with all diode jumpers in place. Removal of any jumper allows its channels to run concurrently.
 - Make sure jumpers SEL2-SEL5 are present on the monitor board.

NOTES

- To prevent "flash-conflict" problems, insert red flash program blocks for all vehicle load switches in the output file. The installer shall verify that signal heads flash in accordance with the signal plan.
- Program phases 4 and 8 for Dual Entry.
- Program controller to start up in phase 2 Green No Walk and 6 Green No Walk.
- If this signal will be managed by an ATMS software, enable controller and detector logging for all detectors used at this location.

EQUIPMENT INFORMATION

Controller.....2070LX
 Cabinet.....332 w/ Aux
 Software.....Q-Free MAXTIME
 Cabinet Mount.....Base
 Output File Positions.....18 With Aux. Output File
 Load Switches Used.....S1, S2, S3, S4, S5, S6, S8, S9, S10, S12, S13
 Phases Used.....1, 2, 3, 4, 5, 6, 8
 Overlap "1".....*
 Overlap "2".....*
 Overlap "3".....*
 Overlap "4".....*
 *See overlap programming detail on sheet 2

SIGNAL HEAD HOOK-UP CHART

LOAD SWITCH NO.	S1	S2	S2P	S3	S4	S4P	S5	S6	S6P	S7	S8	S8P	S9	S10	S11	S12	S13	S14
CMU CHANNEL NO.	1	2	13	3	4	14	5	6	15	7	8	16	9	10	17	11	12	18
PHASE	1	2	2 PED	3	4	4 PED	5	6	6 PED	7	8	8 PED	OL1	OL2	SPARE	OL3	OL4	SPARE
SIGNAL HEAD NO.	11	82	21,22	NU	31	22	41,42	NU	51	61,62	NU	81,82	NU	11	31	NU	51	43
RED	*	128		*	101			134			107							
YELLOW		129			102		*	135			108							
GREEN		130			103			136			109							
RED ARROW													A121	A124		A114	A101	
YELLOW ARROW		126			117								A122	A125		A115	A102	
FLASHING YELLOW ARROW													A123	A126		A116	A103	
GREEN ARROW	127	127		118	118			133										

NU = Not Used
 * Denotes install load resistor. See load resistor installation detail this sheet.
 * See pictorial of head wiring in detail this sheet.

INPUT FILE POSITION LAYOUT

(front view)

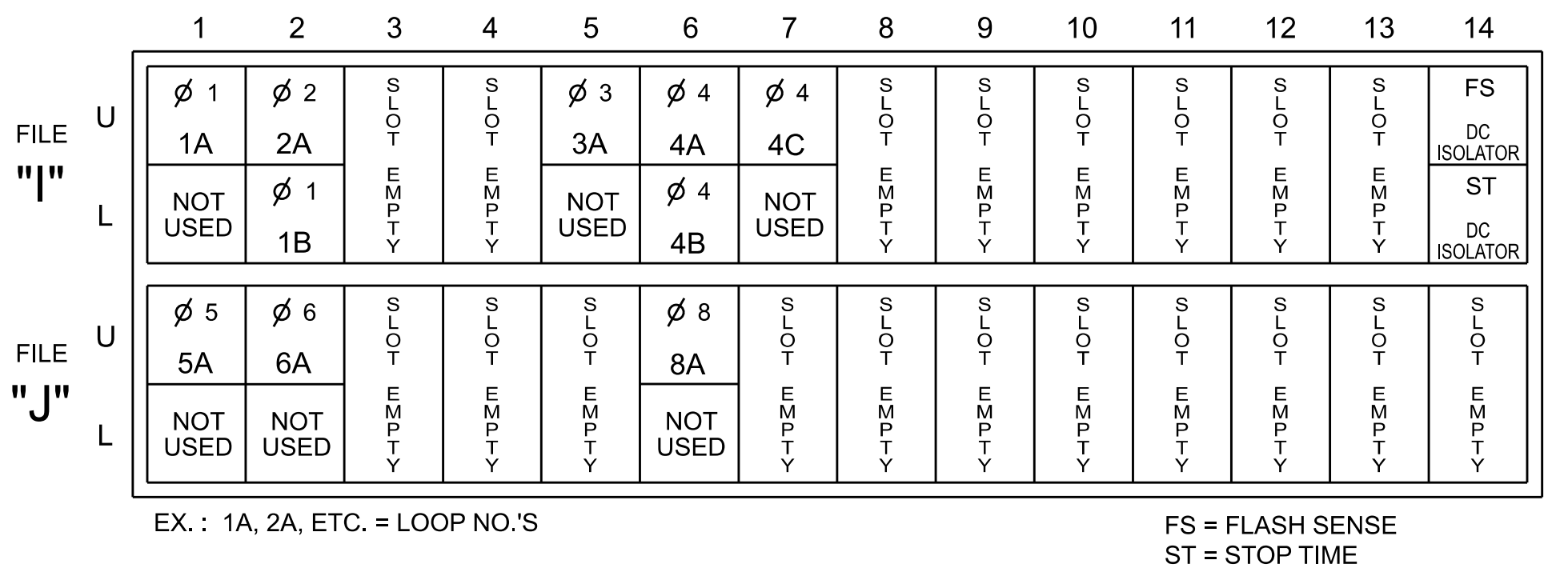

EX.: 1A, 2A, ETC. = LOOP NO.'S
 FS = FLASH SENSE
 ST = STOP TIME

INPUT FILE CONNECTION & PROGRAMMING CHART

LOOP NO.	LOOP TERMINAL	INPUT FILE POS.	PIN NO.	INPUT POINT	DETECTOR NO.	CALL PHASE	DELAY TIME	EXTEND TIME	EXTEND	ADDED INITIAL	CALL	DELAY DURING GREEN
1A	TB2-1,2	I1U	56	18	1 *	1	15.0		X		X	
1B	TB2-7,8	I2L	43	5	29 *	6	3.0		X		X	X
2A	TB2-5,6	I2U	39	1	2				X	X	X	
3A	TB4-5,6	I5U	58	20	7 *	3	15.0		X		X	
4A	TB4-9,10	I6U	41	3	8	4	3.0		X		X	
4B	TB4-11,12	I6L	45	7	9	4	10.0		X		X	
4C	TB6-1,2	I7U	65	31	10	4	15.0		X		X	
5A	TB3-1,2	J1U	55	17	15 *	5	15.0		X		X	
6A	TB3-5,6	J2U	40	2	16	6			X	X	X	
8A	TB5-9,10	J6U	42	4	22	8	10.0		X		X	

* For the detectors to work as shown on the signal plan see the Detector Programming Detail for Alternate Phasing on Sheet 2 of this plan.

INPUT FILE POSITION LEGEND: J2L

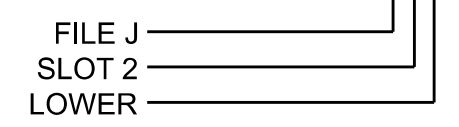

FYA SIGNAL WIRING DETAIL

(wire signal heads as shown)

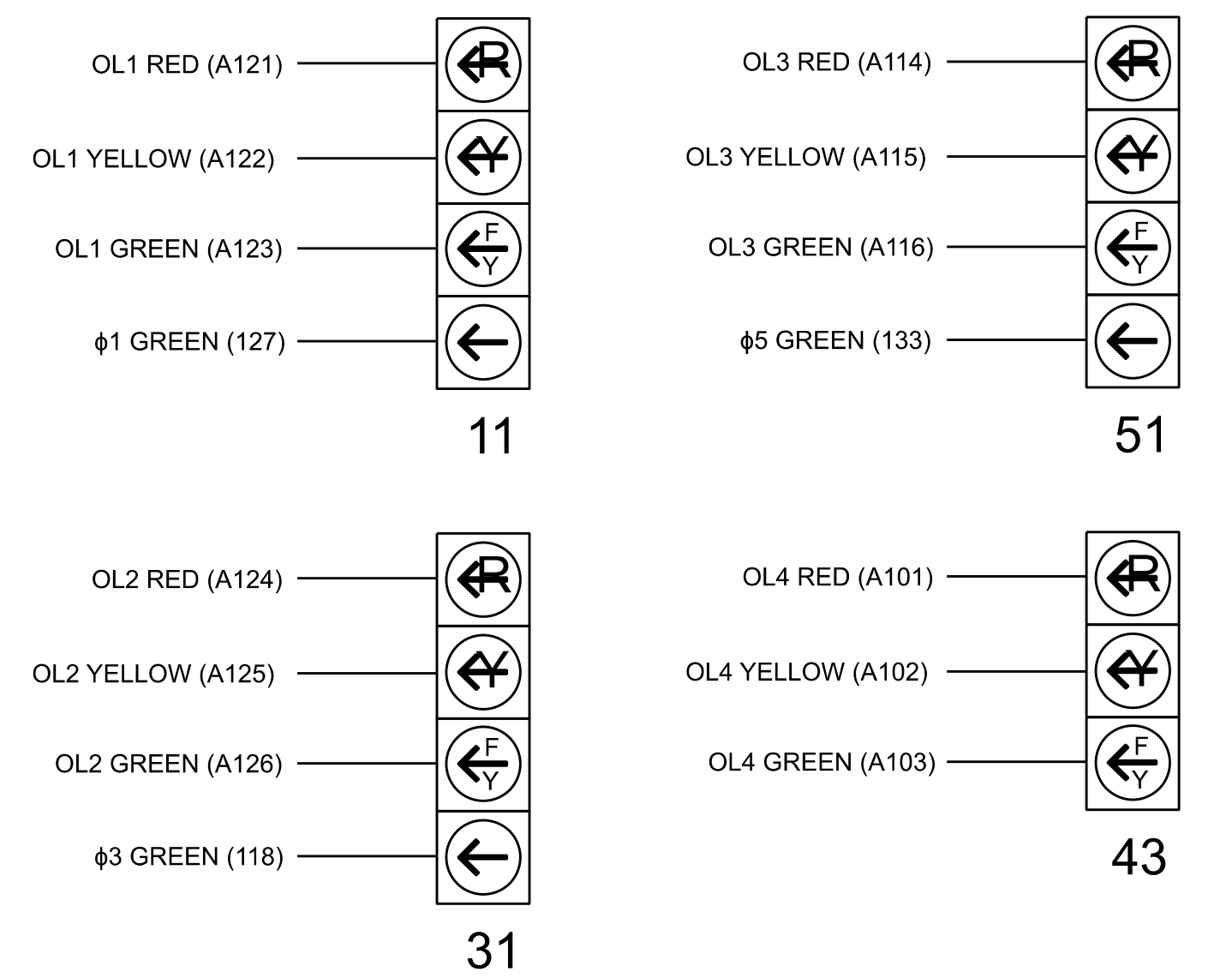

LOAD RESISTOR INSTALLATION DETAIL

(install resistors as shown)

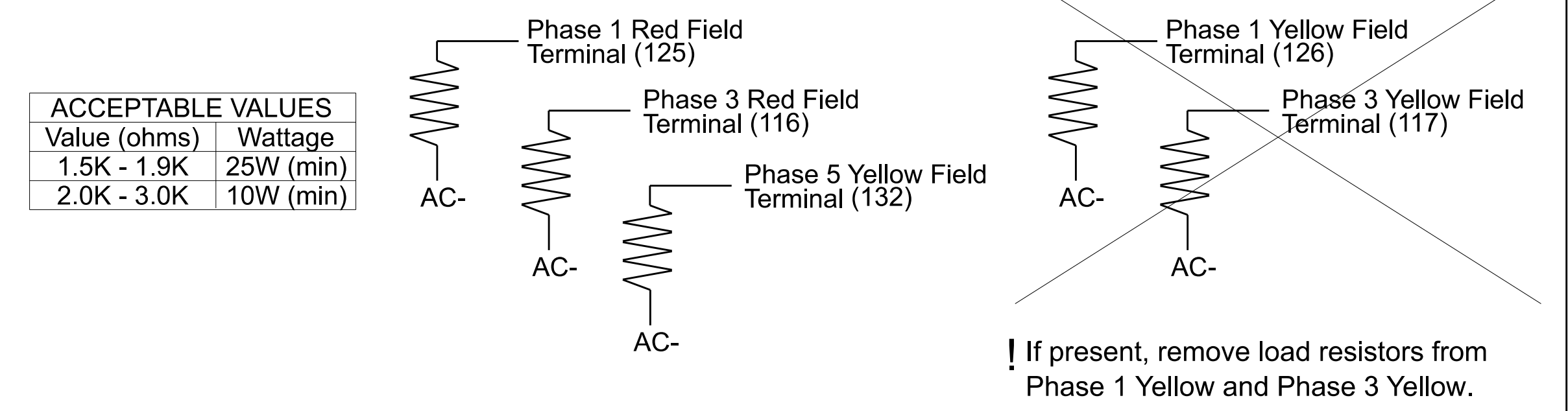

THIS ELECTRICAL DETAIL IS FOR THE SIGNAL DESIGN: 05-1331
 DESIGNED: March 2025
 SEALED: 05/01/2025
 REVISED: N/A

Electrical Detail - Sheet 1 of 2

Prepared in the Offices of:
 Transportation Mobility and Safety Division
 Wake County
 750 N. Greenfield Pkwy, Garner, NC 27529

NC 98 (Durham Road) at SR 1005 (Six Forks Road) and SR 1907 (New Light Road)

Division 5
 PLAN DATE: April 2025
 PREPARED BY: Sarah Kirkpatrick

Wake Forest
 REVIEWED BY:
 REVIEWED BY:

REVISIONS

INIT. DATE

Seal: Ryan W. Hough, Professional Engineer, No. 036833, State of North Carolina

Signed by: Ryan W. Hough, 05/01/2025

DATE

SIG. INVENTORY NO. 05-1331

DOCUMENT NOT CONSIDERED FINAL UNLESS ALL SIGNATURES COMPLETED

I:\MY-2025-13-31...
 p:\ncdot-pw\beam\ey.com\ncdot-pw-01\Documents\ACDOT-TSMO\SIGNAL-DESIGN-Sect1-ar014\signal_05-05-1331\Signal Management\051331-sm.e_20250501.dgn
 5/1/2025 1:32:33

MAXTIME ALTERNATE PHASING ACTIVATION DETAIL

To run alternate phasing, select a Pattern that is programmed to run Overlap Plan 2 and Detector Plan 2. A Pattern can be selected through the scheduler or manually by changing the Operational Mode.

PHASING	OVERLAP PLAN	VEH DET PLAN
ACTIVE PLAN REQUIRED TO RUN DEFAULT PHASING	1	1
ACTIVE PLAN REQUIRED TO RUN ALTERNATE PHASING	2	2

ALTERNATE PHASING CHANGE SUMMARY

THE FOLLOWING IS A SUMMARY OF WHAT TAKES PLACE WHEN OVERLAP PLAN 2 AND VEHICLE DETECTOR PLAN 2 ACTIVATE TO CALL THE "ALTERNATE PHASING":

OVERLAP PLAN 2: Modifies overlap included phases for heads 11, 31 and 51 to run protected turns only.

VEH DET PLAN 2: Disables phase 6 call on loop 1A and reduces delay time for phase 1 call on loop 1A to 3 seconds.

Disables phase 8 call on loop 3A and reduces delay time for phase 3 call on loop 3A to 3 seconds.

Disables phase 2 call on loop 5A and reduces delay time for phase 5 call on loop 5A to 3 seconds.

MAXTIME OVERLAP PROGRAMMING DETAIL FOR DEFAULT PHASING

Front Panel
Main Menu >Controller >Overlap >Overlap Parameters/Overlap Timings

Web Interface
Home >Controller >Overlap Configuration >Overlaps

Overlap Plan 1

Overlap	1	2	3	4
Type	FYA 4 - Section	FYA 4 - Section	FYA 4 - Section	FYA 4 - Section
Included Phases	2	4	6	8
Modifier Phases	1	3	5	-
Modifier Overlaps	-	-	-	-
Trail Green	0	0	0	0
Trail Yellow	0.0	0.0	0.0	0.0
Trail Red	0.0	0.0	0.0	0.0

MAXTIME ALTERNATE PHASING PATTERN PROGRAMMING DETAIL

Front Panel
Main Menu >Controller >Coordination >Patterns

Web Interface
Home >Controller >Coordination >Patterns

Pattern Parameters

Pattern	Veh Det Plan	Overlap Plan
*	2	2

*The Pattern number(s) are to be determined by the Division and/or City Traffic Engineer.

MAXTIME OVERLAP PROGRAMMING DETAIL FOR ALTERNATE PHASING

Front Panel
Main Menu >Controller >Overlap >Overlap Parameters/Overlap Timings

Web Interface
Home >Controller >Overlap Configuration >Overlaps

In the table view of the web interface, right click on "Overlap" in the top left corner of the table. Copy the entire contents of Overlap Plan 1. Paste Overlap Plan 1 into Overlap Plan 2. Modify Overlap Plan 2 as shown below and save changes.

Overlap Plan 2

Overlap	1	2	3	4
Type	FYA 4 - Section	FYA 4 - Section	FYA 4 - Section	FYA 4 - Section
Included Phases	-	-	-	8
Modifier Phases	1	3	5	-
Modifier Overlaps	-	-	-	-
Trail Green	0	0	0	0
Trail Yellow	0.0	0.0	0.0	0.0
Trail Red	0.0	0.0	0.0	0.0

← NOTICE INCLUDED PHASE

MAXTIME DETECTOR PROGRAMMING DETAIL FOR ALTERNATE PHASING LOOPS 1A, 3A & 5A

Front Panel
Main Menu >Controller >Detector >Veh Det Plans

Web Interface
Home >Controller >Detector Configuration >Vehicle Detectors

In the table view of web interface right click on "Detector" in the top left corner of the table. Copy the entire contents of Detector Plan 1. Paste Detector Plan 1 into Detector Plan 2. Modify Detector Plan 2 as shown below and save changes.

	Plan 2		
	Detector	Call Phase	Delay
1A	1	1	3.0
	29	0	3.0
3A	7	3	3.0
	30	0	3.0
5A	15	5	3.0
	31	0	3.0

OUTPUT CHANNEL CONFIGURATION

Front Panel
Main Menu >Controller >More>Channels>Channels Config

Web Interface
Home >Controller >Advanced IO>Channels>Channel Configuration

Channel Configuration

Channel	Control Type	Control Source	Flash Yellow	Flash Red	Flash Alt	MMU Channel
1	Phase Vehicle	1		X	X	1
2	Phase Vehicle	2		X		2
3	Phase Vehicle	3		X	X	3
4	Phase Vehicle	4		X		4
5	Phase Vehicle	5		X		5
6	Phase Vehicle	6		X	X	6
7	Phase Vehicle	7		X		7
8	Phase Vehicle	8		X	X	8
9	Overlap	1		X	X	9
10	Overlap	2		X	X	10
11	Overlap	3		X		11
12	Overlap	4		X		12
13	Phase Ped	2				13
14	Phase Ped	4				14
15	Phase Ped	6				15
16	Phase Ped	8				16
17	Overlap	5		X	X	17
18	Overlap	6		X		18

MAXTIME STARTUP AND SOFTWARE FLASH PROGRAMMING DETAIL

Front Panel
Main Menu >Controller >Unit

Web Interface
Home >Controller >Unit

Modify parameters as shown below and save changes.

Start Up Parameters	Unit Flash Parameters
StartUp Clearance Hold 6	All Red Flash Exit Time 6

FLASHER CIRCUIT MODIFICATION DETAIL

IN ORDER TO INSURE THAT SIGNALS FLASH CONCURRENTLY ON THE SAME APPROACH, MAKE THE FOLLOWING FLASHER CIRCUIT CHANGES:

- ON REAR OF PDA - REMOVE WIRE FROM TERM. T2-4 AND TERMINATE ON T2-2.
- ON REAR OF PDA - REMOVE WIRE FROM TERM. T2-5 AND TERMINATE ON T2-3.
- REMOVE FLASHER UNIT 2.

THE CHANGES LISTED ABOVE TIES ALL PHASES AND OVERLAPS TO FLASHER UNIT 1.

THIS ELECTRICAL DETAIL IS FOR THE SIGNAL DESIGN: 05-1331
DESIGNED: March 2025
SEALED: 05/01/2025
REVISED: N/A

Electrical Detail - Sheet 2 of 2

Prepared in the Offices of:  750 N. Greenfield Pkwy, Garner, NC 27529	NC 98 (Durham Road) at SR 1005 (Six Forks Road) and SR 1907 (New Light Road)		SEAL NORTH CAROLINA PROFESSIONAL ENGINEER RYAN W. HOUGH 036833
	Division 5 PLAN DATE: April 2025 PREPARED BY: Sarah Kirkpatrick	Wake County REVIEWED BY: REVIEWED BY:	

DOCUMENT NOT CONSIDERED FINAL UNLESS ALL SIGNATURES COMPLETED

SIG. INVENTORY NO. 05-1331

18 CHANNEL IP CONFLICT MONITOR PROGRAMMING DETAIL

(remove jumpers and set switches as shown)

REMOVE DIODE JUMPERS 1-5, 1-6, 1-9, 1-11, 1-15, 2-5, 2-6, 2-9, 2-11, 2-13, 2-15, 3-7, 3-8, 3-10, 3-12, 3-16, 4-7, 4-8, 4-10, 4-12, 4-14, 4-16, 5-9, 5-11, 5-13, 6-9, 6-11, 6-13, 6-15, 7-10, 7-12, 7-14, 8-10, 8-12, 8-14, 8-16, 9-11, 9-13, 9-15, 10-12, 10-14, 10-16, 11-13, 11-15, 12-14, 12-16, 13-15 and 14-16.

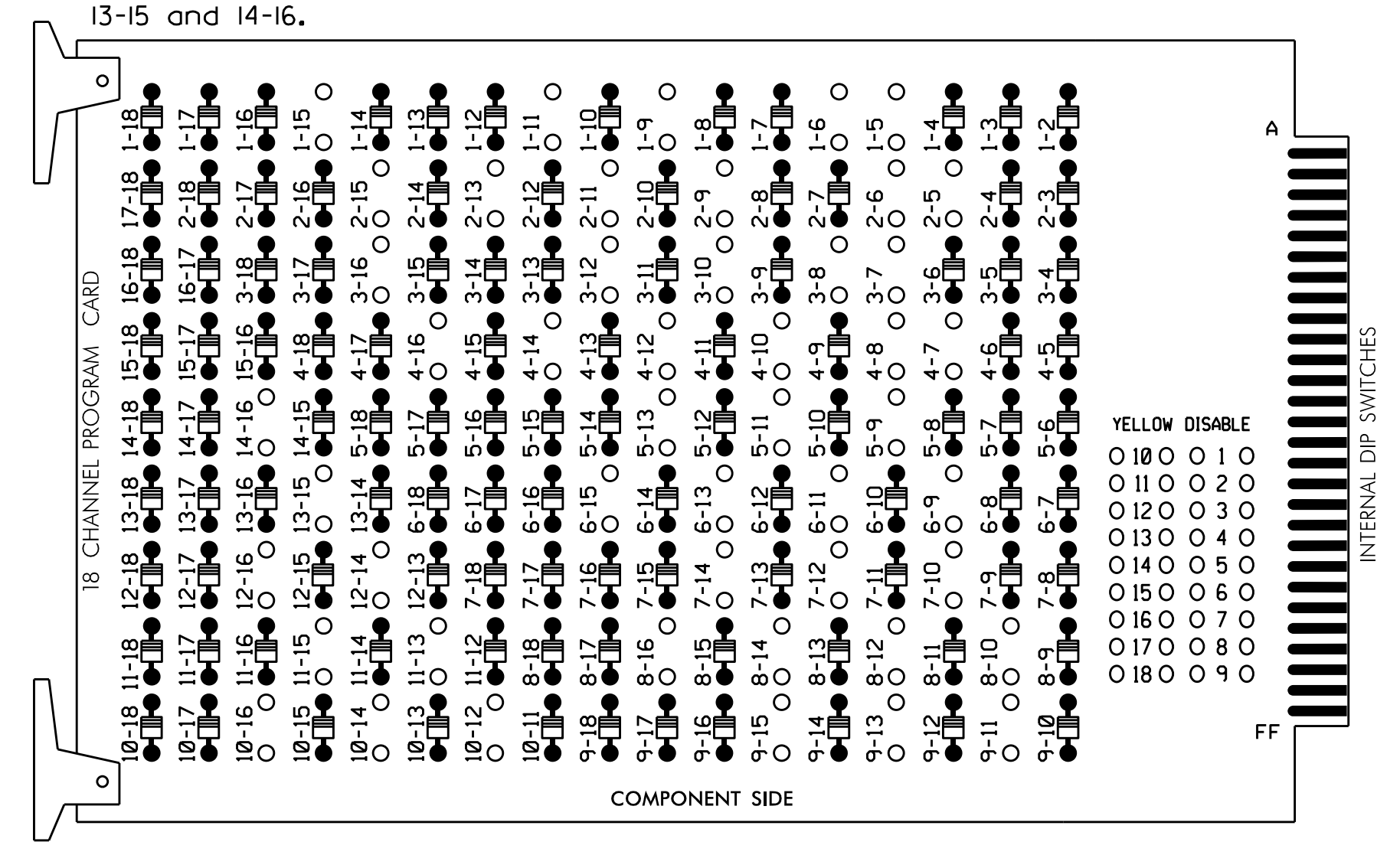

REMOVE JUMPERS AS SHOWN

- NOTES:
- Card is provided with all diode jumpers in place. Removal of any jumper allows its channels to run concurrently.
 - Ensure jumpers SEL2-SEL5 and SEL9 are present on the monitor board.
 - Ensure that Red Enable is active at all times during normal operation.
 - Integrate monitor with Ethernet network in cabinet.

■ = DENOTES POSITION OF SWITCH

NOTES

- To prevent "flash-conflict" problems, insert red flash program blocks for all vehicle load switches in the output file. The installer shall verify that signal heads flash in accordance with the Signal Plans.
- Program phases 4 and 8 for Dual Entry.
- Program controller to start up in phase 2 Green and 6 Green.
- The cabinet and controller are part of the Durham Signal System.

EQUIPMENT INFORMATION

CONTROLLER.....2070LX
 CABINET.....332 W/AUX
 SOFTWARE.....ECONOLITE ASC/3-2070
 CABINET MOUNT.....BASE
 OUTPUT FILE POSITIONS...18 WITH AUX. OUTPUT FILE
 LOAD SWITCHES USED.....S1,S2,S3,S4,S5,S6,S7,S8,S9,
 S10,S11,S12,AUX S1,AUX S2,
 AUX S4,AUX S5
 PHASES USED.....1,2,2PED,3,4,4PED,5,6,6PED,7,8,8PED
 OVERLAP A.....*
 OVERLAP B.....*
 OVERLAP C.....*
 OVERLAP D.....*
 * See overlap programming detail on sheet 3

SIGNAL HEAD HOOK-UP CHART

LOAD SWITCH NO.	S1	S2	S3	S4	S5	S6	S7	S8	S9	S10	S11	S12	AUX S1	AUX S2	AUX S3	AUX S4	AUX S5	AUX S6	
CMU CHANNEL NO.	1	2	13	3	4	14	5	6	15	7	8	16	9	10	17	11	12	18	
PHASE	1	2	2 PED	3	4	4 PED	5	6	6 PED	7	8	8 PED	OLA	OLB	SPARE	OLC	OLD	SPARE	
SIGNAL HEAD NO.	11*	21,22	P21, P22	22	31*	41,42	P41, P42	51*	61,62	P61, P62	71*	81,82	P81, P82	11*	31*	NU	51*	71*	NU
RED		128		*	101			134		*	107								
YELLOW	*	129			102		*	135			108								
GREEN		130			103			136			109								
RED ARROW																A121	A124	A114	A101
YELLOW ARROW				117							123					A122	A125	A115	A102
FLASHING YELLOW ARROW																A123	A126	A116	A103
GREEN ARROW	127			118	118			133			124	124							
Hand			113					104			119								110
Person								106			121								112

NU = Not Used
 * Denotes install load resistor. See load resistor installation detail this sheet.
 * See pictorial of head wiring in detail below.

FYA SIGNAL WIRING DETAIL

(wire signal heads as shown)

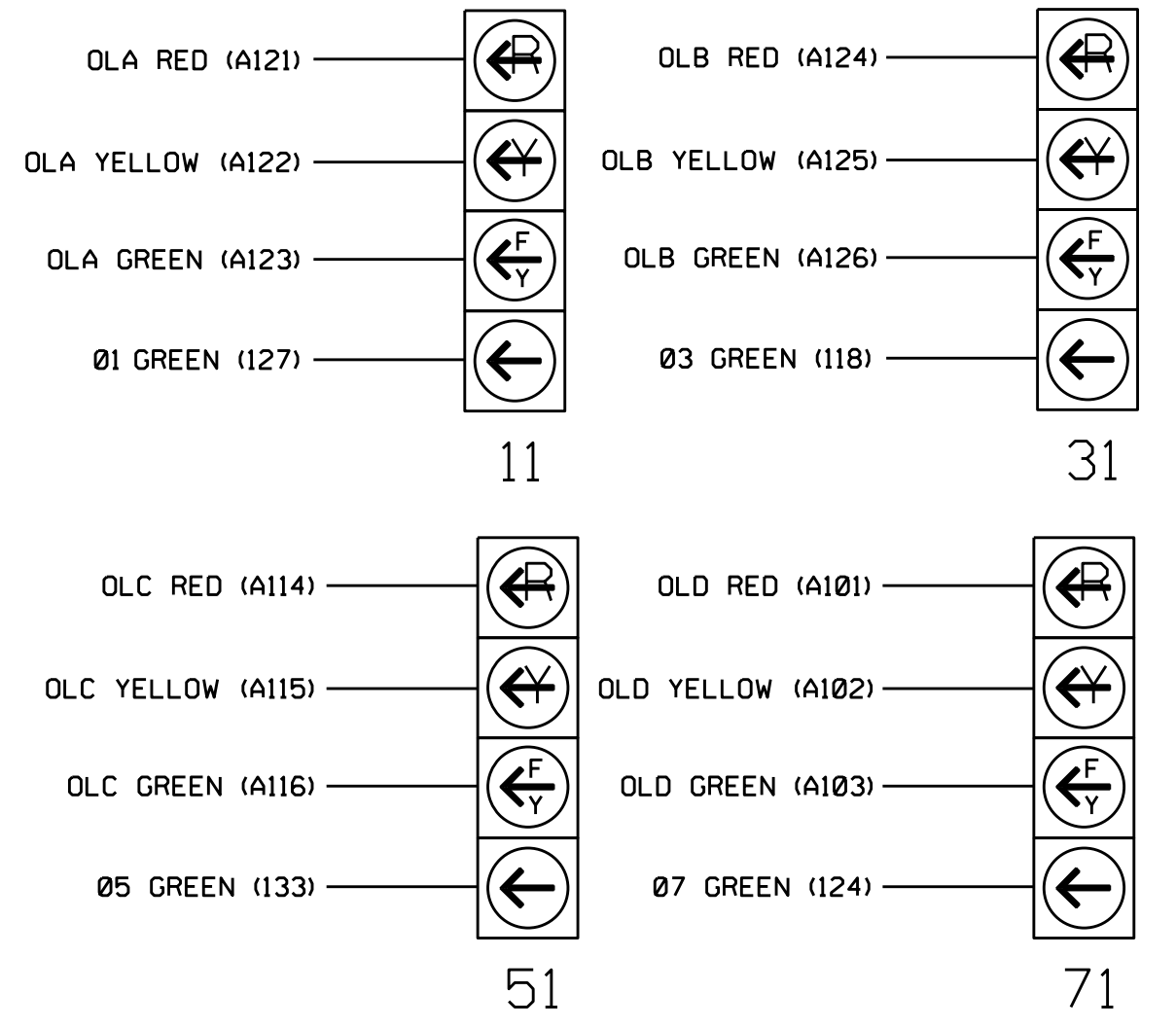

INPUT FILE POSITION LAYOUT

(front view)

FILE	1	2	3	4	5	6	7	8	9	10	11	12	13	14
U	∅ 1	∅ 2	∅ 3	∅ 4	∅ 5	∅ 6	∅ 7	∅ 8	∅ 9	∅ 10	∅ 11	∅ 12	∅ 13	∅ 14
L	1A	2A	3A	4A	5A	6A	7A	8A	9A	10A	11A	12A	13A	14A
U	NOT USED	∅ 2	NOT USED	∅ 4	NOT USED	NOT USED	NOT USED	NOT USED	NOT USED	NOT USED	NOT USED	NOT USED	NOT USED	NOT USED
L	2B	3B	4B	5B	6B	7B	8B	9B	10B	11B	12B	13B	14B	FS

EX.: 1A, 2A, ETC. = LOOP NO.'S
 FS = FLASH SENSE
 ST = STOP TIME
 * Wired Input - Do not populate slot with detector card

INPUT FILE CONNECTION & PROGRAMMING CHART

LOOP NO.	LOOP TERMINAL	INPUT FILE POS.	PIN NO.	DETECTOR NO.	NEMA PHASE	CALL	EXTEND TIME	DELAY TIME	ADDED INITIAL	DETECTOR TYPE
1A ¹	TB2-1,2	I1U	56	1	1	YES		15		S
2A	TB2-5,6	J2U	48	26	6	YES		3		G
2B	TB2-7,8	I2L	43	12	2	YES			X	N
3A ²	TB4-5,6	I5U	58	3	3	YES		10		S
4A	TB4-9,10	I6U	41	4	4	YES				S
4B	TB4-11,12	I6L	45	14	4	YES		10		S
5A ³	TB3-1,2	J1U	55	5	5	YES		15		S
6A	TB3-5,6	J2U	40	6	6	YES			X	N
6B	TB3-7,8	J2L	44	16	6	YES			X	N
7A ⁴	TB5-5,6	J5U	57	7	7	YES		10		S
8A	TB5-9,10	J6U	42	8	8	YES				S
8B	TB6-9,10	I9U	60	11	8	YES		15		S
PED PUSH BUTTONS										
P21,P22	TB8-4,6	I12U	67	PED 2	2 PED					
P41,P42	TB8-5,6	I12L	69	PED 4	4 PED					
P61,P62	TB8-7,9	I13U	68	PED 6	6 PED					
P81,P82	TB8-8,9	I13L	70	PED 8	8 PED					

NOTE:
 INSTALL DC ISOLATORS IN INPUT FILE SLOTS 112 AND 113.

- Add jumper from I1-W to J4-W. on rear of input file.
- Add jumper from I5-W to J8-W. on rear of input file.
- Add jumper from J1-W to I4-W. on rear of input file.
- Add jumper from J5-W to I8-W. on rear of input file.

* For the detectors to work as shown on the signal design plan, see the Vehicle Detector Setup Programming Detail for Alternate Phasing on sheet 2.

INPUT FILE POSITION LEGEND: J2L

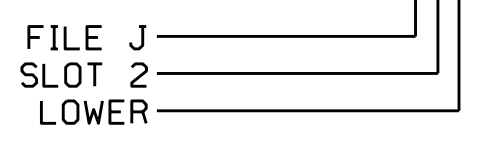

LOAD RESISTOR INSTALLATION DETAIL

(install resistors as shown below)

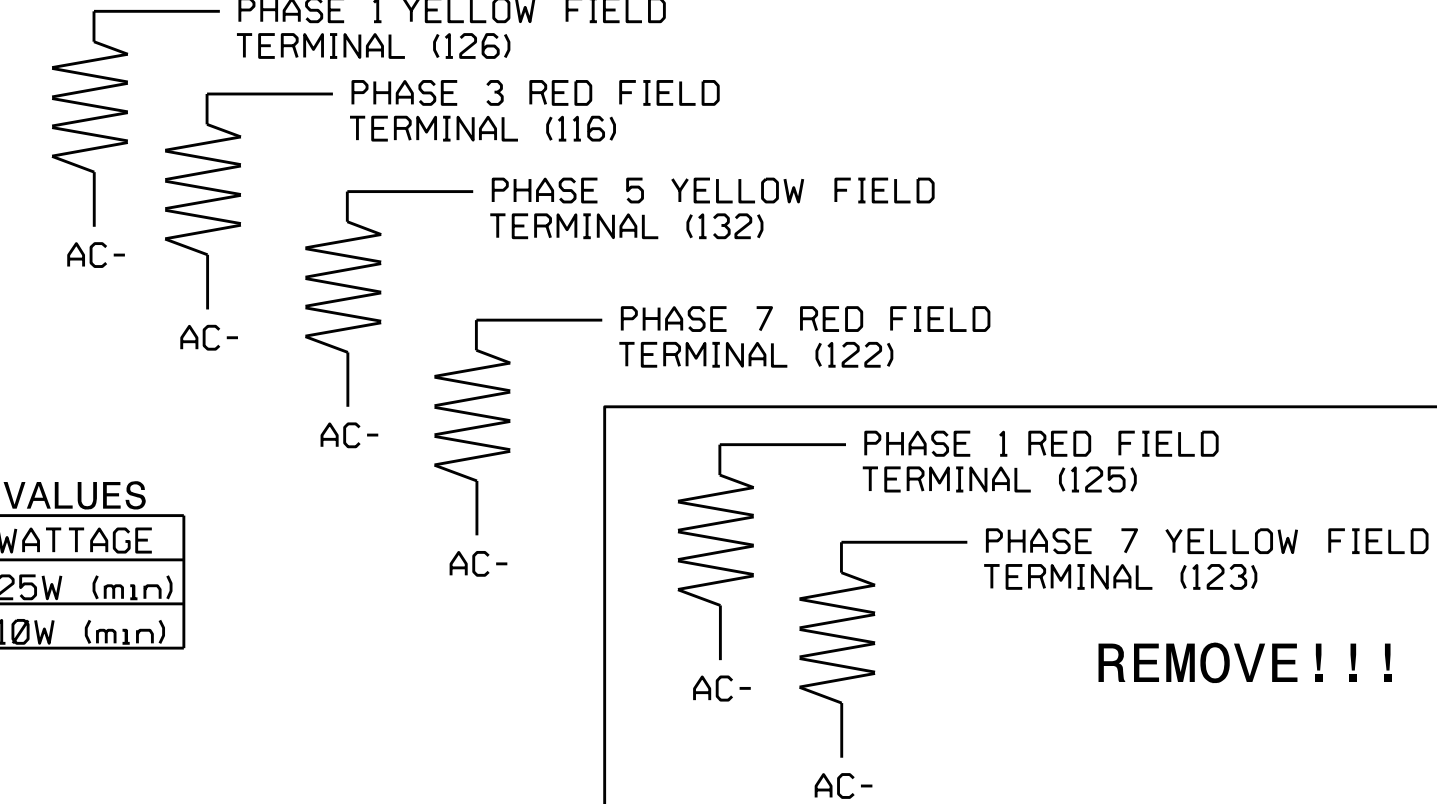

VALUE (ohms)	WATTAGE
1.5K - 1.9K	25W (min)
2.0K - 3.0K	10W (min)

REMOVE!!!

COUNTDOWN PEDESTRIAN SIGNAL OPERATION

Countdown Ped Signals are required to display timing only during Ped Clearance Interval. Consult Ped Signal Module user's manual for instructions on selecting this feature.

THIS ELECTRICAL DETAIL IS FOR THE SIGNAL DESIGN: 05-2008
 DESIGN: April 2025
 SEALED: 08/11/2025
 REVISED: N/A

Electrical Detail - Sheet 1 of 5

	NC 54 (S. Miami Boulevard) at SR 1978 (Hopson Road)/ SR 1973 (Page Road)		SEAL PROFESSIONAL ENGINEER RYAN W. HOUGH SEAL 036833
	Division 5 Durham County Durham	Division 5 Durham County Durham	
Prepared For:	PLAN DATE: July 2025 PREPARED BY: S.Kirkpatrick	REVIEWED BY:	SIGNED BY: Ryan W. Hough DATE: 08/11/2025
REVISIONS	INIT.	DATE	SIGNED BY: Ryan W. Hough DATE: 08/11/2025

18 CHANNEL IP CONFLICT MONITOR PROGRAMMING DETAIL

(remove jumpers and set switches as shown)

REMOVE DIODE JUMPERS 1-5, 1-6, 1-9, 1-11, 2-5, 2-6, 2-9, 2-11, 2-13, 3-7, 3-8, 3-10, 3-12, 4-7, 4-8, 4-10, 4-12, 4-14, 5-9, 5-11, 5-13, 6-9, 6-11, 6-13, 7-10, 7-12, 7-14, 8-10, 8-12, 8-14, 9-11, 9-13, 10-12, 10-14, 11-13 and 12-14.

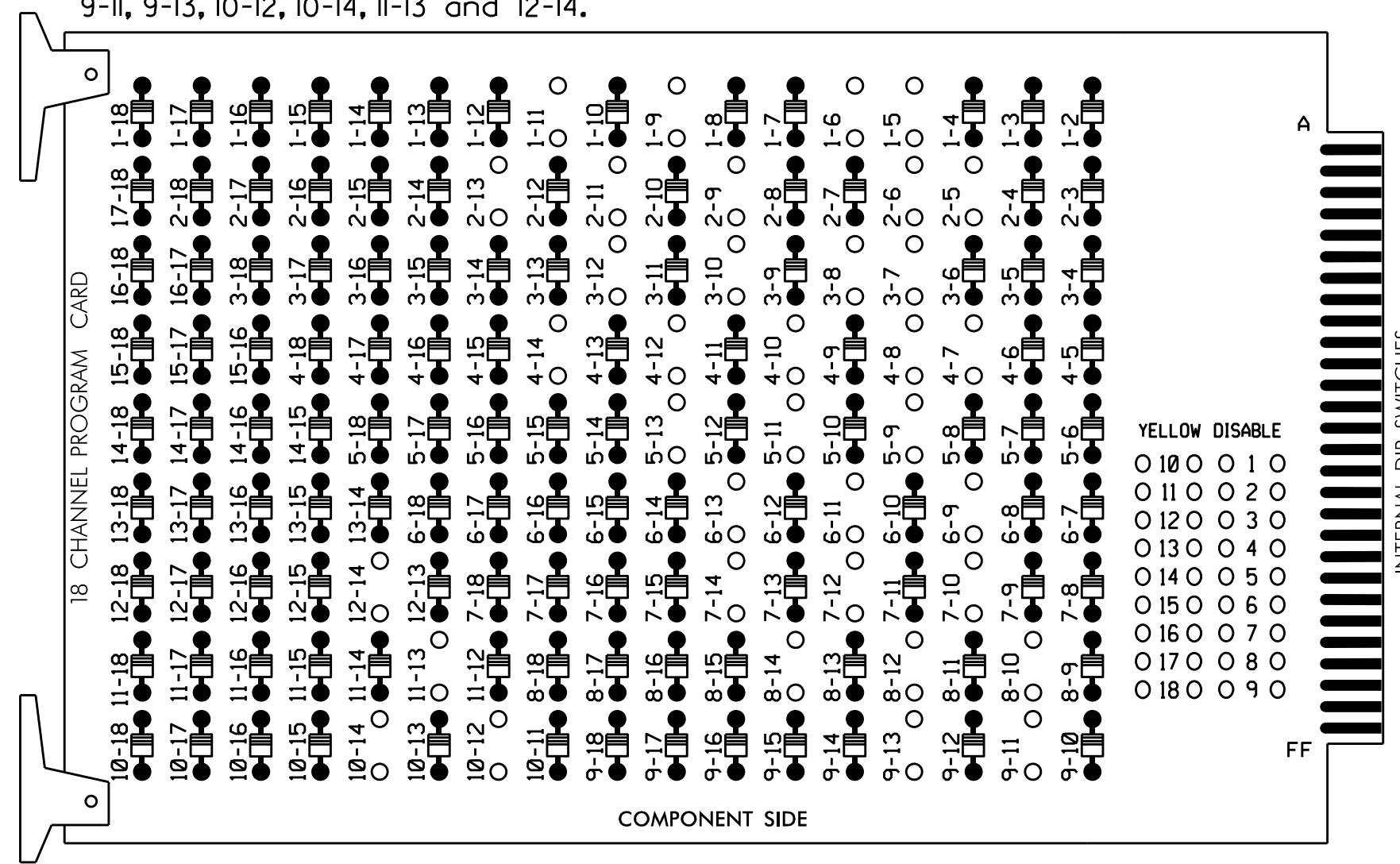

REMOVE JUMPERS AS SHOWN

NOTES:

- Card is provided with all diode jumpers in place. Removal of any jumper allows its channels to run concurrently.
- Ensure jumpers SEL2-SEL5 and SEL9 are present on the monitor board.
- Ensure that Red Enable is active at all times during normal operation.
- Integrate monitor with Ethernet network in cabinet.

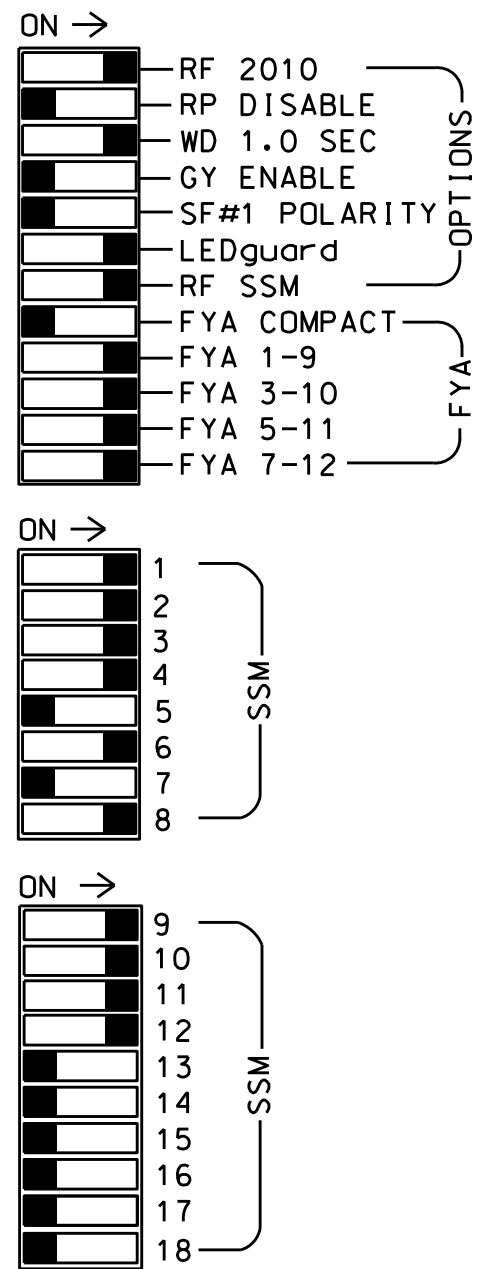
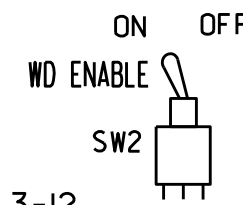

■ = DENOTES POSITION OF SWITCH

NOTES

- To prevent "flash-conflict" problems, insert red flash program blocks for all vehicle load switches in the output file. The installer shall verify that signal heads flash in accordance with the Signal Plans.
- Program phases 4 and 8 for Dual Entry.
- Program controller to start up in phase 2 Green and 6 Green.
- The cabinet and controller are part of the Durham Signal System.

EQUIPMENT INFORMATION

CONTROLLER.....2070LX
 CABINET.....332 W/AUX
 SOFTWARE.....ECONOLITE ASC/3-2070
 CABINET MOUNT.....BASE
 OUTPUT FILE POSITIONS...18 WITH AUX. OUTPUT FILE
 LOAD SWITCHES USED.....S1,S2,S3,S4,S5,S6,S7,S8,S10,
 S11,AUX S1,AUX S2,AUX S4,
 AUX S5
 PHASES USED.....1,2,2PED,3,4,4PED,5,6,7,8
 OVERLAP A.....*
 OVERLAP B.....*
 OVERLAP C.....*
 OVERLAP D.....*
 * See overlap programming detail on sheet 3

SPECIAL DETECTOR NOTE

Install a video detection system for vehicle detection for zones 1A, 6A and 6B. Perform installation according to manufacturer's directions and NCDOT engineer-approved mounting locations to accomplish the detection schemes shown on the Signal Design Plans.

For detection zone 1A the equipment placement and slots reserved for wired inputs are typical for a NCDOT installation. Inputs associated with these slots are compatible with time of day instructions located on sheet 2 of this electrical detail.

INPUT FILE POSITION LAYOUT

(front view)

	1	2	3	4	5	6	7	8	9	10	11	12	13	14
FILE "I"	∅ 1 1A	∅ 2 2A	∅ 3 3A	∅ 4 4A	∅ 5 5A	∅ 6 6A	∅ 7 7A	∅ 8 8A	∅ 9 9A	∅ 10 10A	∅ 11 11A	∅ 12 12A	∅ 13 13A	∅ 14 14A
FILE "J"	NOT USED	NOT USED	NOT USED	NOT USED	NOT USED	NOT USED	NOT USED	NOT USED	NOT USED	NOT USED	NOT USED	NOT USED	NOT USED	NOT USED

EX.: 1A, 2A, ETC. = LOOP NO.'S

FS = FLASH SENSE
 ST = STOP TIME

⊗ Wired Input - Do not populate slot with detector card

INPUT FILE CONNECTION & PROGRAMMING CHART

LOOP NO.	LOOP TERMINAL	INPUT FILE POS.	PIN NO.	DETECTOR NO.	NEMA PHASE	CALL	EXTEND TIME	DELAY TIME	ADDED INITIAL	DETECTOR TYPE
1A ¹	TB2-1,2	I1U	56	1	★	1	YES	15		S
	-	J4U	48	26	★	6	YES	3		G
2A	TB2-5,6	I2U	39	2		2	YES		X	N
	TB2-7,8	I2L	43	12		2	YES		X	N
3A ²	TB4-5,6	I5U	58	3	★	3	YES	10		S
	-	J8U	50	28	★	8	YES			S
4A	TB4-9,10	I6U	41	4		4	YES			S
	TB4-11,12	I6L	45	14		4	YES	10		S
5A ³	TB3-1,2	J1U	55	5	★	5	YES	15		S
	-	I4U	47	22	★	2	YES	3		G
7A ⁴	TB5-5,6	J5U	57	7	★	7	YES	10		S
	-	I8U	49	24	★	4	YES			S
8A	TB5-9,10	J6U	42	8		8	YES			S
	TB6-9,10	I9U	60	11		1	YES	15		S
PED PUSH BUTTONS										
P21,P22	TB8-4,6	I12U	67	PED 2		2 PED				
P41,P42	TB8-5,6	I12L	69	PED 4		4 PED				

NOTE:
 INSTALL DC ISOLATORS IN INPUT FILE SLOT I12.

- Add jumper from I1-W to J4-W, on rear of input file.
- Add jumper from I5-W to J8-W, on rear of input file.
- Add jumper from J1-W to I4-W, on rear of input file.
- Add jumper from J5-W to I8-W, on rear of input file.

★ For the detectors to work as shown on the signal design plan, see the Vehicle Detector Setup Programming Detail for Alternate Phasing on sheet 2.

INPUT FILE POSITION LEGEND: J2L

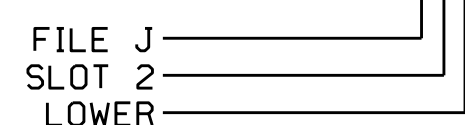

SIGNAL HEAD HOOK-UP CHART

LOAD SWITCH NO.	S1	S2	S3	S4	S5	S6	S7	S8	S9	S10	S11	S12	AUX S1	AUX S2	AUX S3	AUX S4	AUX S5	AUX S6	
CMU CHANNEL NO.	1	2	13	3	4	14	5	6	15	7	8	16	9	10	17	11	12	18	
PHASE	1	2	2 PED	3	4	4 PED	5	6	6 PED	7	8	8 PED	OLA	OLB	SPARE	OLC	OLD	SPARE	
SIGNAL HEAD NO.	11★	82	21,22	P21, P22	22	31★	41,42	P41, P42	51★	61,62	NU	71★	81,82	NU	11★	31★	NU	51★	71★
RED	*	128		*	101		134		107										
YELLOW		129			102		* 135		* 108										
GREEN		130			103		136		109										
RED ARROW													A121	A124		A114	A101		
YELLOW ARROW	126			117									A122	A125		A115	A102		
FLASHING YELLOW ARROW													A123	A126		A116	A103		
GREEN ARROW	127	127		118	118		133		124										
Hand				113			104												
Person				115			106												

NU = Not Used

- * Denotes install load resistor. See load resistor installation detail this sheet.
- ★ See pictorial of head wiring in detail below.

FYA SIGNAL WIRING DETAIL

(wire signal heads as shown)

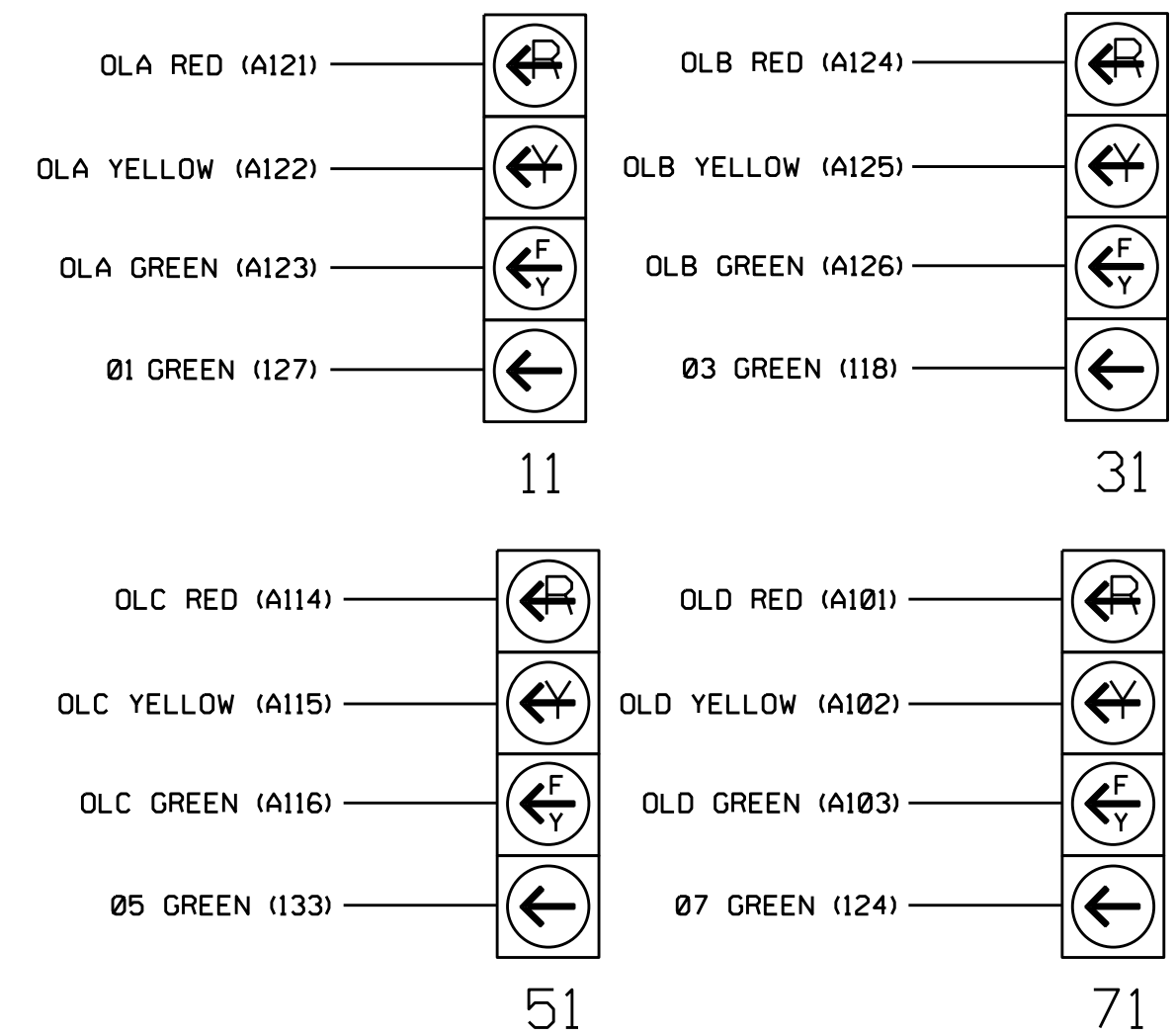

COUNTDOWN PEDESTRIAN SIGNAL OPERATION

Countdown Ped Signals are required to display timing only during Ped Clearance Interval. Consult Ped Signal Module user's manual for instructions on selecting this feature.

LOAD RESISTOR INSTALLATION DETAIL

(install resistors as shown below)

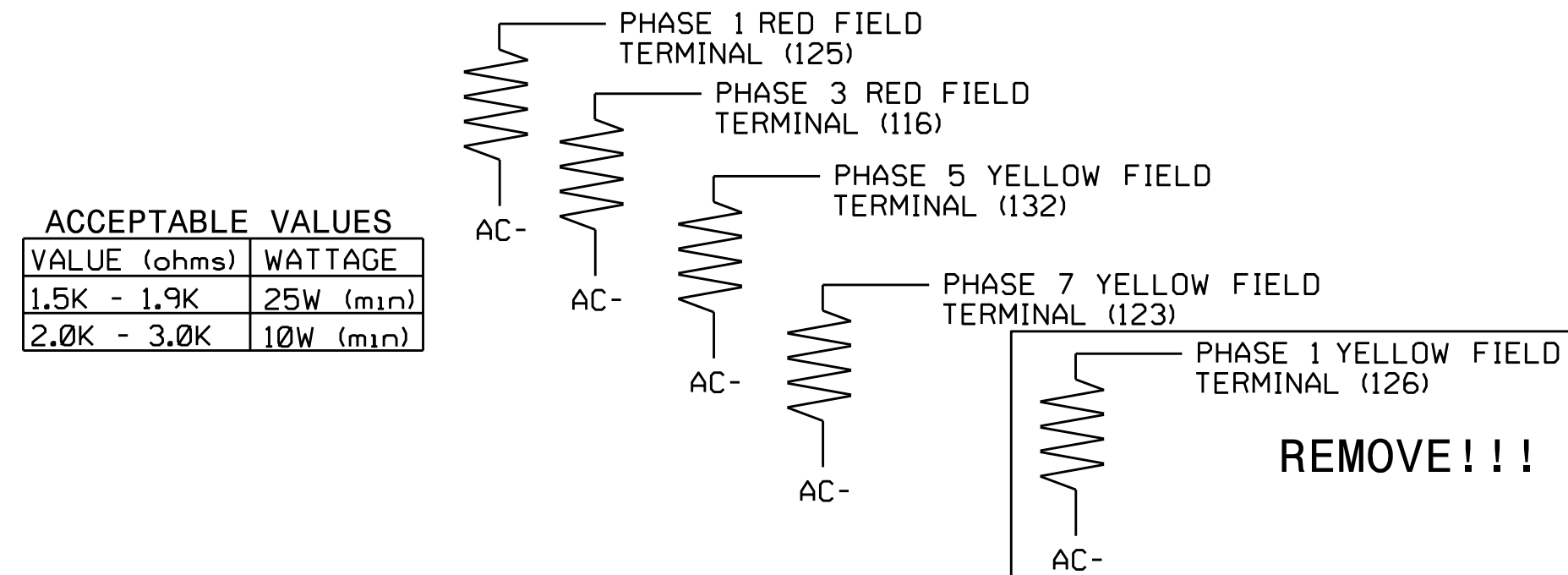

VALUE (ohms)	WATTAGE
1.5K - 1.9K	25W (min)
2.0K - 3.0K	10W (min)

REMOVE!!!

Electrical Detail - Sheet 1 of 5

Electrical and Programming Details For:

NC 54 (S. Miami Boulevard) at SR 1978 (Hopson Road) / SR 1973 (Page Road)

Division 5 Durham County Durham

PLAN DATE: July 2025 REVIEWED BY:

PREPARED BY: S.Kirkpatrick REVIEWED BY:

REVISIONS	INIT.	DATE

DOCUMENT NOT CONSIDERED FINAL UNLESS ALL SIGNATURES COMPLETED

SEAL

Signed by: Ryan W. Houff 08/11/2025

43032FAA28543 DATE

SIG. INVENTORY NO. 05-2008T1

18 CHANNEL IP CONFLICT MONITOR PROGRAMMING DETAIL

(remove jumpers and set switches as shown)

REMOVE DIODE JUMPERS 1-5, 1-6, 1-9, 1-11, 2-5, 2-6, 2-9, 2-11, 2-13, 3-7, 3-8, 3-10, 3-12, 4-7, 4-8, 4-10, 4-12, 4-14, 5-9, 5-11, 5-13, 6-9, 6-11, 6-13, 7-10, 7-12, 7-14, 8-10, 8-12, 8-14, 9-11, 9-13, 10-12, 10-14, 11-13 and 12-14.

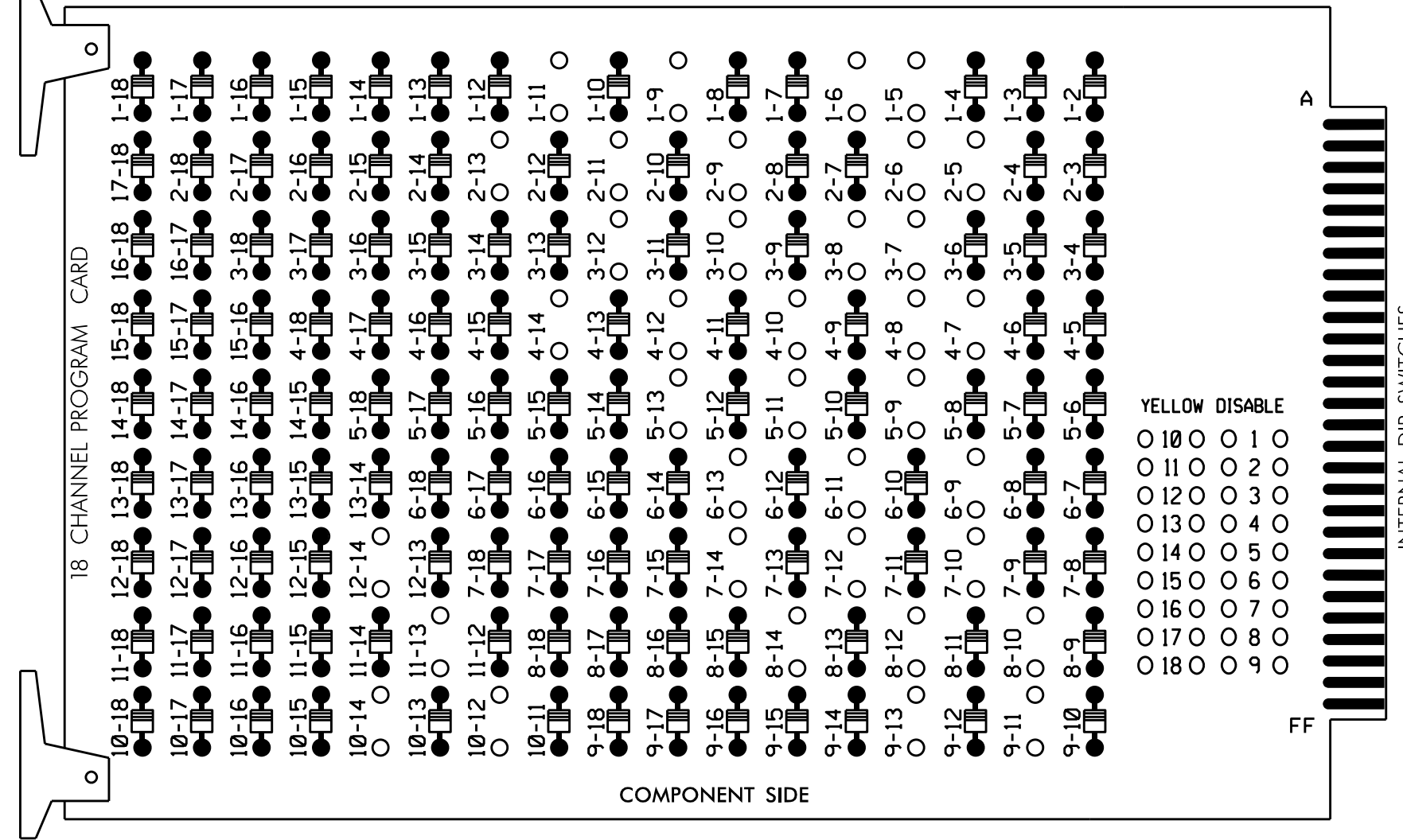

REMOVE JUMPERS AS SHOWN

NOTES:

- Card is provided with all diode jumpers in place. Removal of any jumper allows its channels to run concurrently.
- Ensure jumpers SEL2-SEL5 and SEL9 are present on the monitor board.
- Ensure that Red Enable is active at all times during normal operation.
- Integrate monitor with Ethernet network in cabinet.

■ = DENOTES POSITION OF SWITCH

NOTES

- To prevent "flash-conflict" problems, insert red flash program blocks for all vehicle load switches in the output file. The installer shall verify that signal heads flash in accordance with the Signal Plans.
- Program phases 4 and 8 for Dual Entry.
- Program controller to start up in phase 2 Green and 6 Green.
- The cabinet and controller are part of the Durham Signal System.

EQUIPMENT INFORMATION

CONTROLLER.....2070LX
 CABINET.....332 W/AUX
 SOFTWARE.....ECONOLITE ASC/3-2070
 CABINET MOUNT.....BASE
 OUTPUT FILE POSITIONS...18 WITH AUX. OUTPUT FILE
 LOAD SWITCHES USED.....S1,S2,S3,S4,S5,S6,S7,S8,S10,
 AUX S5
 PHASES USED.....1,2,2PED,3,4,4PED,5,6,7,8
 OVERLAP A.....*
 OVERLAP B.....*
 OVERLAP C.....*
 OVERLAP D.....*
 * See overlap programming detail on sheet 3

SPECIAL DETECTOR NOTE

Install a video detection system for vehicle detection for zones 1A, 6A and 6B. Perform installation according to manufacturer's directions and NCDOT engineer-approved mounting locations to accomplish the detection schemes shown on the Signal Design Plans.

For detection zone 1A the equipment placement and slots reserved for wired inputs are typical for a NCDOT installation. Inputs associated with these slots are compatible with time of day instructions located on sheet 2 of this electrical detail.

INPUT FILE POSITION LAYOUT

(front view)

FILE	1	2	3	4	5	6	7	8	9	10	11	12	13	14
U	∅ 1 1A	∅ 2 2A	∅ 3 3A	∅ 4 4A	∅ 5 5A	∅ 6 6A	∅ 7 7A	∅ 8 8A	∅ 9 9A	∅ 10 10A	∅ 11 11A	∅ 12 12A	∅ 13 13A	∅ 14 14A
L	NOT USED	∅ 2 2B	NOT USED	∅ 4 4B	NOT USED	NOT USED	NOT USED	NOT USED	NOT USED	NOT USED	NOT USED	NOT USED	NOT USED	NOT USED
U	∅ 5 5A	∅ 6 6A	∅ 7 7A	∅ 8 8A	∅ 9 9A	∅ 10 10A	∅ 11 11A	∅ 12 12A	∅ 13 13A	∅ 14 14A	∅ 15 15A	∅ 16 16A	∅ 17 17A	∅ 18 18A
L	NOT USED	NOT USED	NOT USED	NOT USED	NOT USED	NOT USED	NOT USED	NOT USED	NOT USED	NOT USED	NOT USED	NOT USED	NOT USED	NOT USED

EX.: 1A, 2A, ETC. = LOOP NO.'S

FS = FLASH SENSE
 ST = STOP TIME

⊗ Wired Input - Do not populate slot with detector card

INPUT FILE CONNECTION & PROGRAMMING CHART

LOOP NO.	LOOP TERMINAL	INPUT FILE POS.	PIN NO.	DETECTOR NO.	NEMA PHASE	CALL	EXTEND TIME	DELAY TIME	ADDED INITIAL	DETECTOR TYPE
1A ¹	TB2-1,2	I1U	56	1 ★	1	YES		15		S
	-	J4U	48	26 ★	6	YES		3		G
2A	TB2-5,6	I2U	39	2	2	YES			X	N
	TB2-7,8	I2L	43	12	2	YES			X	N
3A ²	TB4-5,6	I5U	58	3 ★	3	YES		10		S
	-	J8U	50	28 ★	8	YES				S
4A	TB4-9,10	I6U	41	4	4	YES				S
	TB4-11,12	I6L	45	14	4	YES		10		S
5A ³	TB3-1,2	J1U	55	5 ★	5	YES		15		S
	-	I4U	47	22 ★	2	YES		3		G
7A ⁴	TB5-5,6	J5U	57	7 ★	7	YES		10		S
	-	I8U	49	24 ★	4	YES				S
8A	TB5-9,10	J6U	42	8	8	YES				S
	TB6-9,10	I9U	60	11	1	YES		15		S
PED PUSH BUTTONS										
P21,P22	TB8-4,6	I12U	67	PED 2	2 PED					
P41,P42	TB8-5,6	I12L	69	PED 4	4 PED					

NOTE:
 INSTALL DC ISOLATORS IN INPUT FILE SLOT I12.

- Add jumper from I1-W to J4-W, on rear of input file.
- Add jumper from I5-W to J8-W, on rear of input file.
- Add jumper from J1-W to I4-W, on rear of input file.
- Add jumper from J5-W to I8-W, on rear of input file.

★ For the detectors to work as shown on the signal design plan, see the Vehicle Detector Setup Programming Detail for Alternate Phasing on sheet 2.

INPUT FILE POSITION LEGEND: J2L

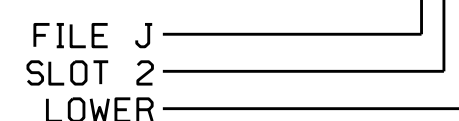

SIGNAL HEAD HOOK-UP CHART

LOAD SWITCH NO.	S1	S2	S3	S4	S5	S6	S7	S8	S9	S10	S11	S12	AUX S1	AUX S2	AUX S3	AUX S4	AUX S5	AUX S6	
CMU CHANNEL NO.	1	2	13	3	4	14	5	6	15	7	8	16	9	10	17	11	12	18	
PHASE	1	2	2 PED	3	4	4 PED	5	6	6 PED	7	8	8 PED	OLA	OLB	SPARE	OLC	OLD	SPARE	
SIGNAL HEAD NO.	11 ★	82	21,22	P21, P22	22	31 ★	41,42	P41, P42	51 ★	61,62	NU	71 ★	81,82	NU	11 ★	31 ★	NU	51 ★	71 ★
RED	*	128		*	101		134		107										
YELLOW		129			102		* 135		* 108										
GREEN		130			103		136		109										
RED ARROW															A121	A124		A114	A101
YELLOW ARROW	126				117										A122	A125		A115	A102
FLASHING YELLOW ARROW															A123	A126		A116	A103
GREEN ARROW	127	127			118	118		133		124									
Hand					113			104											
Walking					115			106											

NU = Not Used

- * Denotes install load resistor. See load resistor installation detail this sheet.
- ★ See pictorial of head wiring in detail below.

FYA SIGNAL WIRING DETAIL

(wire signal heads as shown)

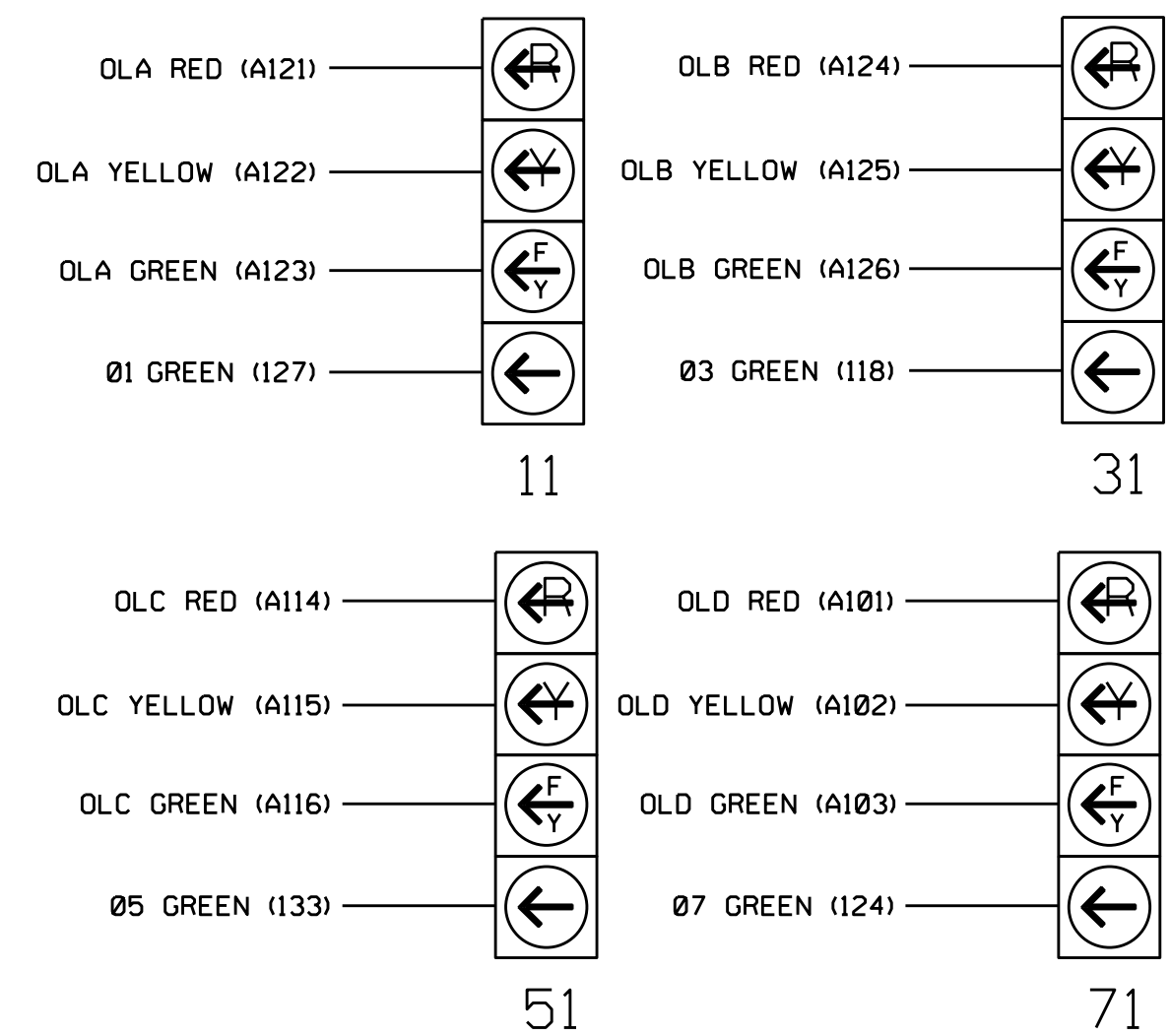

COUNTDOWN PEDESTRIAN SIGNAL OPERATION

Countdown Ped Signals are required to display timing only during Ped Clearance Interval. Consult Ped Signal Module user's manual for instructions on selecting this feature.

LOAD RESISTOR INSTALLATION DETAIL

(install resistors as shown below)

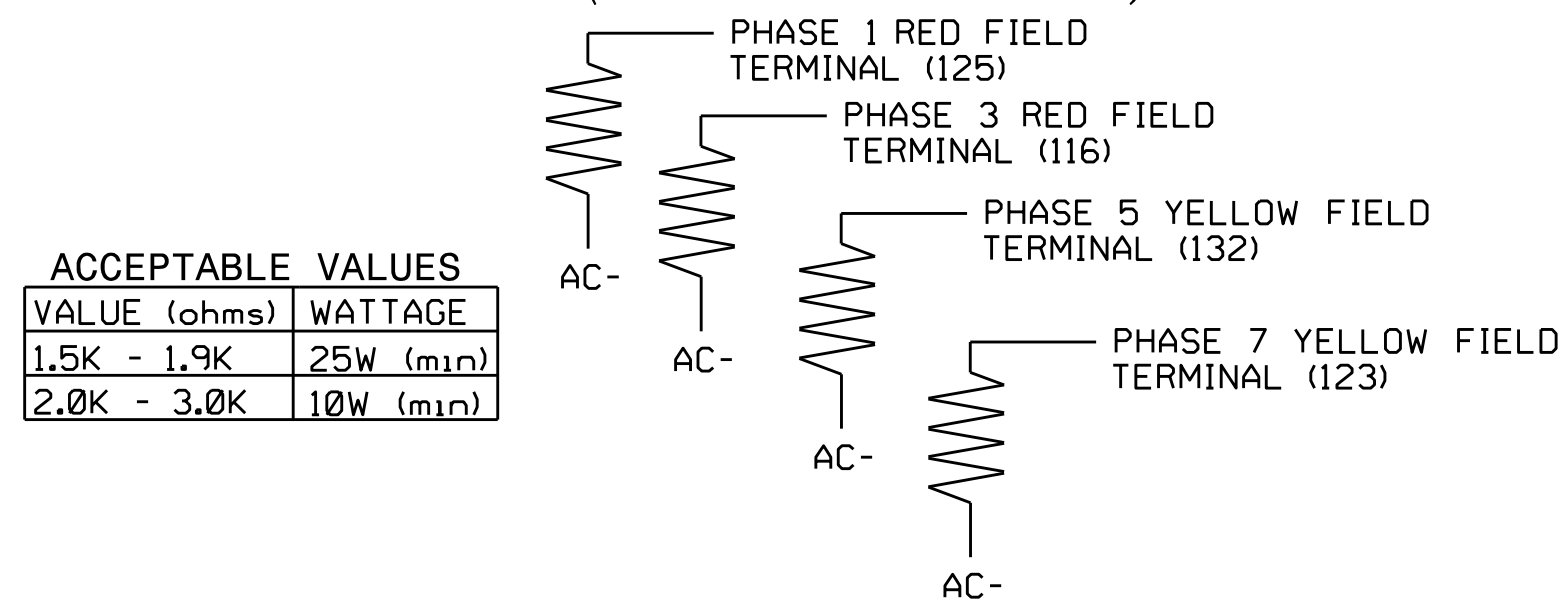

Electrical Detail - Sheet 1 of 5

Electrical and Programming Details For:

750 N. Greenfield Pkwy, Garner, NC 27529

NC 54 (S. Miami Boulevard) at
 SR 1978 (Hopson Road) /
 SR 1973 (Page Road)

Division 5 Durham County Durham

PLAN DATE: July 2025 REVIEWED BY:

PREPARED BY: S.Kirkpatrick REVIEWED BY:

REVISIONS: INIT. DATE

DOCUMENT NOT CONSIDERED FINAL UNLESS ALL SIGNATURES COMPLETED

SEAL

Signed By: Ryan W. Houff 08/11/2025

430020FA282643 DATE

SIG. INVENTORY NO. 05-2008T2

18 CHANNEL IP CONFLICT MONITOR PROGRAMMING DETAIL

(remove jumpers and set switches as shown)

REMOVE DIODE JUMPERS 1-5, 1-6, 1-9, 1-11, 2-5, 2-6, 2-9, 2-11, 2-13, 3-7, 3-8, 3-10, 3-12, 4-7, 4-8, 4-10, 4-12, 4-14, 5-9, 5-11, 5-13, 6-9, 6-11, 6-13, 7-10, 7-12, 7-14, 8-10, 8-12, 8-14, 9-11, 9-13, 10-12, 10-14, 11-13 and 12-14.

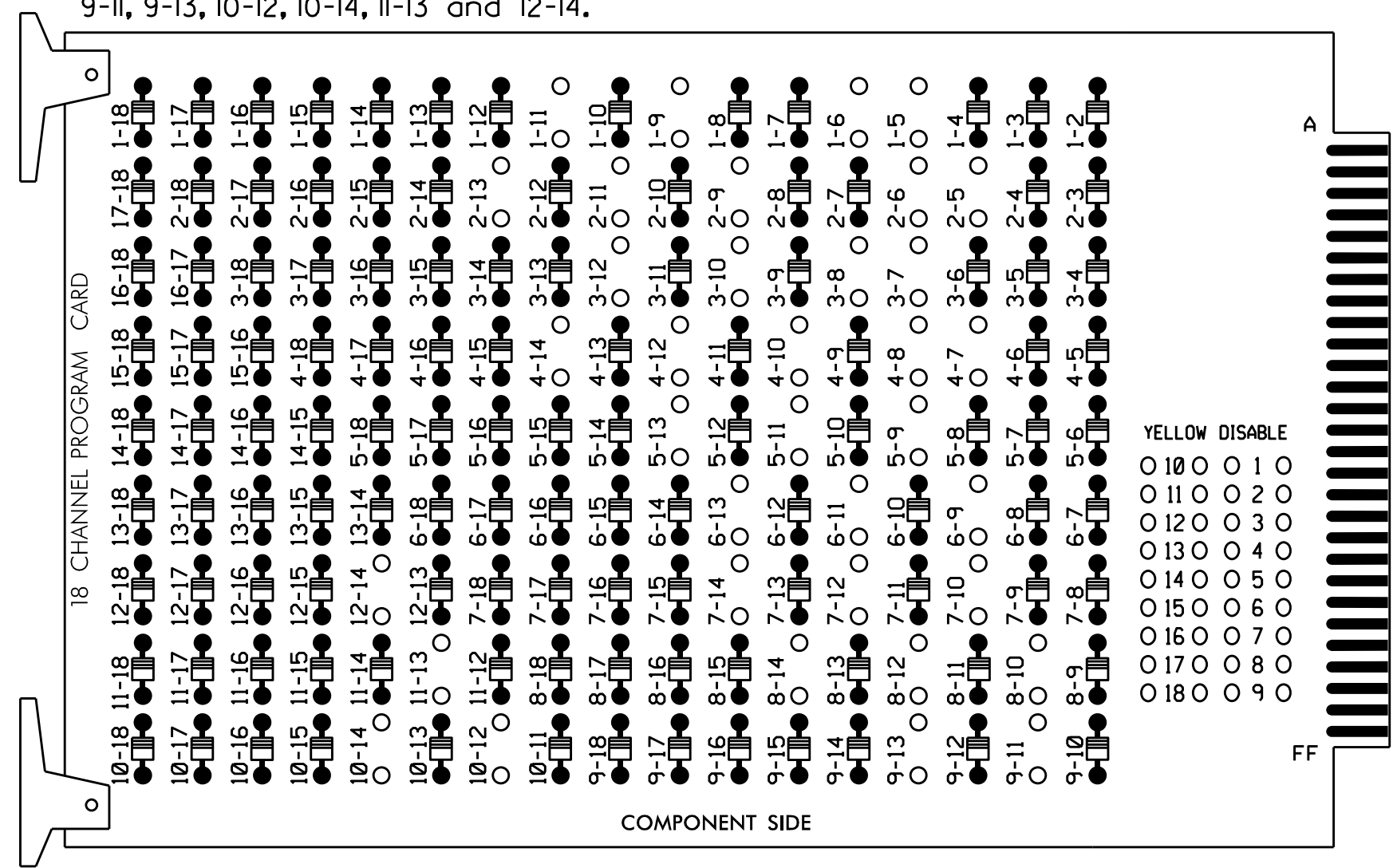

REMOVE JUMPERS AS SHOWN

NOTES:

- Card is provided with all diode jumpers in place. Removal of any jumper allows its channels to run concurrently.
- Ensure jumpers SEL2-SEL5 and SEL9 are present on the monitor board.
- Ensure that Red Enable is active at all times during normal operation.
- Integrate monitor with Ethernet network in cabinet.

■ = DENOTES POSITION OF SWITCH

NOTES

- To prevent "flash-conflict" problems, insert red flash program blocks for all vehicle load switches in the output file. The installer shall verify that signal heads flash in accordance with the Signal Plans.
- Program phases 4 and 8 for Dual Entry.
- Program controller to start up in phase 2 Green and 6 Green.
- The cabinet and controller are part of the Durham Signal System.

EQUIPMENT INFORMATION

CONTROLLER.....2070LX
 CABINET.....332 W/AUX
 SOFTWARE.....ECONOLITE ASC/3-2070
 CABINET MOUNT.....BASE
 OUTPUT FILE POSITIONS...18 WITH AUX. OUTPUT FILE
 LOAD SWITCHES USED.....S1,S2,S3,S4,S5,S6,S7,S8,S10,
 S11,AUX S1,AUX S2,AUX S4,
 AUX S5
 PHASES USED.....1,2,2PED,3,4,4PED,5,6,7,8
 OVERLAP A.....*
 OVERLAP B.....*
 OVERLAP C.....*
 OVERLAP D.....*
 * See overlap programming detail on sheet 3

SPECIAL DETECTOR NOTE

Install a video detection system for vehicle detection for zones 1A, 6A and 6B. Perform installation according to manufacturer's directions and NCDOT engineer-approved mounting locations to accomplish the detection schemes shown on the Signal Design Plans.

For detection zone 1A the equipment placement and slots reserved for wired inputs are typical for a NCDOT installation. Inputs associated with these slots are compatible with time of day instructions located on sheet 2 of this electrical detail.

INPUT FILE POSITION LAYOUT

(front view)

FILE	1	2	3	4	5	6	7	8	9	10	11	12	13	14
U	∅ 1 1A	∅ 2 2A	∅ 3 3A	∅ 4 4A	∅ 5 5A	∅ 6 6A	∅ 7 7A	∅ 8 8A	∅ 9 9A	∅ 10 10A	∅ 11 11A	∅ 12 12A	∅ 13 13A	∅ 14 14A
L	NOT USED	∅ 2 2B	NOT USED	∅ 4 4B	NOT USED	∅ 6 6B	NOT USED	∅ 8 8B	NOT USED	∅ 10 10B	NOT USED	∅ 12 12B	∅ 13 13B	∅ 14 14B
U	∅ 5 5A	∅ 6 6A	∅ 7 7A	∅ 8 8A	∅ 9 9A	∅ 10 10A	∅ 11 11A	∅ 12 12A	∅ 13 13A	∅ 14 14A	∅ 15 15A	∅ 16 16A	∅ 17 17A	∅ 18 18A
L	NOT USED	∅ 6 6B	NOT USED	∅ 8 8B	NOT USED	∅ 10 10B	NOT USED	∅ 12 12B	∅ 13 13B	∅ 14 14B	∅ 15 15B	∅ 16 16B	∅ 17 17B	∅ 18 18B

EX.: 1A, 2A, ETC. = LOOP NO.'S

FS = FLASH SENSE
 ST = STOP TIME

⊗ Wired Input - Do not populate slot with detector card

INPUT FILE CONNECTION & PROGRAMMING CHART

LOOP NO.	LOOP TERMINAL	INPUT FILE POS.	PIN NO.	DETECTOR NO.	NEMA PHASE	CALL	EXTEND TIME	DELAY TIME	ADDED INITIAL	DETECTOR TYPE
1A ¹	TB2-1,2	I1U	56	1 ★	1	YES		15		S
	-	J4U	48	26 ★	6	YES		3		G
2A	TB2-5,6	I2U	39	2	2	YES			X	N
	TB2-7,8	I2L	43	12	2	YES			X	N
3A ²	TB4-5,6	I5U	58	3 ★	3	YES		10		S
	-	J8U	50	28 ★	8	YES				S
4A	TB4-9,10	I6U	41	4	4	YES				S
	TB4-11,12	I6L	45	14	4	YES		10		S
5A ³	TB3-1,2	J1U	55	5 ★	5	YES		15		S
	-	I4U	47	22 ★	2	YES		3		G
7A ⁴	TB5-5,6	J5U	57	7 ★	7	YES		10		S
	-	I8U	49	24 ★	4	YES				S
8A	TB5-9,10	J6U	42	8	8	YES				S
	TB6-9,10	I9U	60	11	1	YES		15		S
PED PUSH BUTTONS										
P21,P22	TB8-4,6	I12U	67	PED 2	2 PED					
P41,P42	TB8-5,6	I12L	69	PED 4	4 PED					

NOTE:
 INSTALL DC ISOLATORS IN INPUT FILE SLOT I12.

- Add jumper from I1-W to J4-W, on rear of input file.
- Add jumper from I5-W to J8-W, on rear of input file.
- Add jumper from J1-W to I4-W, on rear of input file.
- Add jumper from J5-W to I8-W, on rear of input file.

★ For the detectors to work as shown on the signal design plan, see the Vehicle Detector Setup Programming Detail for Alternate Phasing on sheet 2.

INPUT FILE POSITION LEGEND: J2L

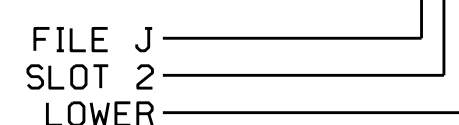

SIGNAL HEAD HOOK-UP CHART

LOAD SWITCH NO.	S1	S2	S3	S4	S5	S6	S7	S8	S9	S10	S11	S12	AUX S1	AUX S2	AUX S3	AUX S4	AUX S5	AUX S6	
CMU CHANNEL NO.	1	2	13	3	4	14	5	6	15	7	8	16	9	10	17	11	12	18	
PHASE	1	2	2 PED	3	4	4 PED	5	6	6 PED	7	8	8 PED	OLA	OLB	SPARE	OLC	OLD	SPARE	
SIGNAL HEAD NO.	11 ★	82	21,22	P21, P22	22	31 ★	41,42	P41, P42	51 ★	61,62	NU	71 ★	81,82	NU	11 ★	31 ★	NU	51 ★	71 ★
RED	*	128		*	101		134		107										
YELLOW		129			102		* 135		* 108										
GREEN		130			103		136		109										
RED ARROW															A121	A124		A114	A101
YELLOW ARROW	126				117										A122	A125		A115	A102
FLASHING YELLOW ARROW															A123	A126		A116	A103
GREEN ARROW	127	127			118	118		133		124									
Hand						113		104											
Walking						115		106											

NU = Not Used

- * Denotes install load resistor. See load resistor installation detail this sheet.
- ★ See pictorial of head wiring in detail below.

FYA SIGNAL WIRING DETAIL

(wire signal heads as shown)

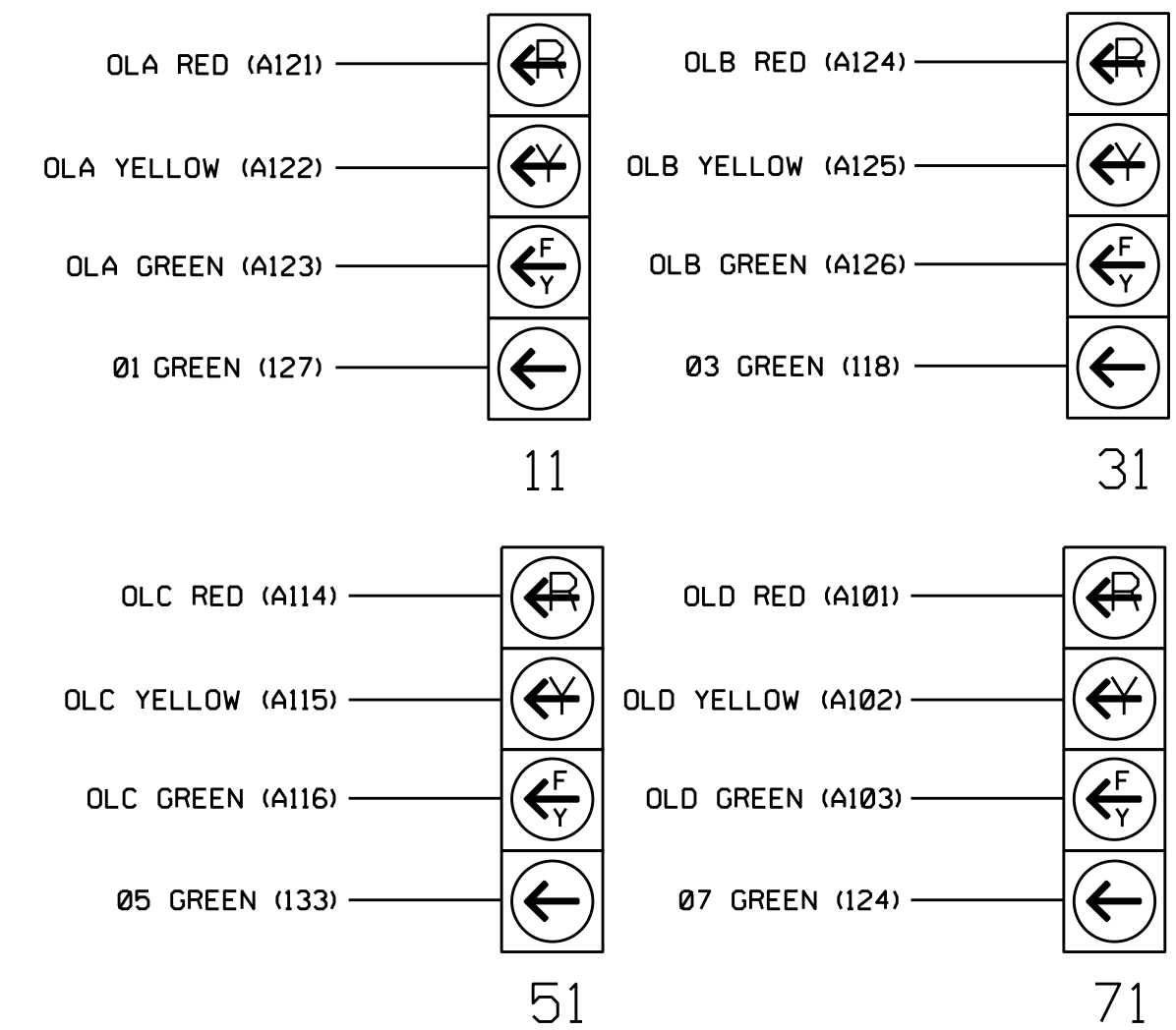

COUNTDOWN PEDESTRIAN SIGNAL OPERATION

Countdown Ped Signals are required to display timing only during Ped Clearance Interval. Consult Ped Signal Module user's manual for instructions on selecting this feature.

LOAD RESISTOR INSTALLATION DETAIL

(install resistors as shown below)

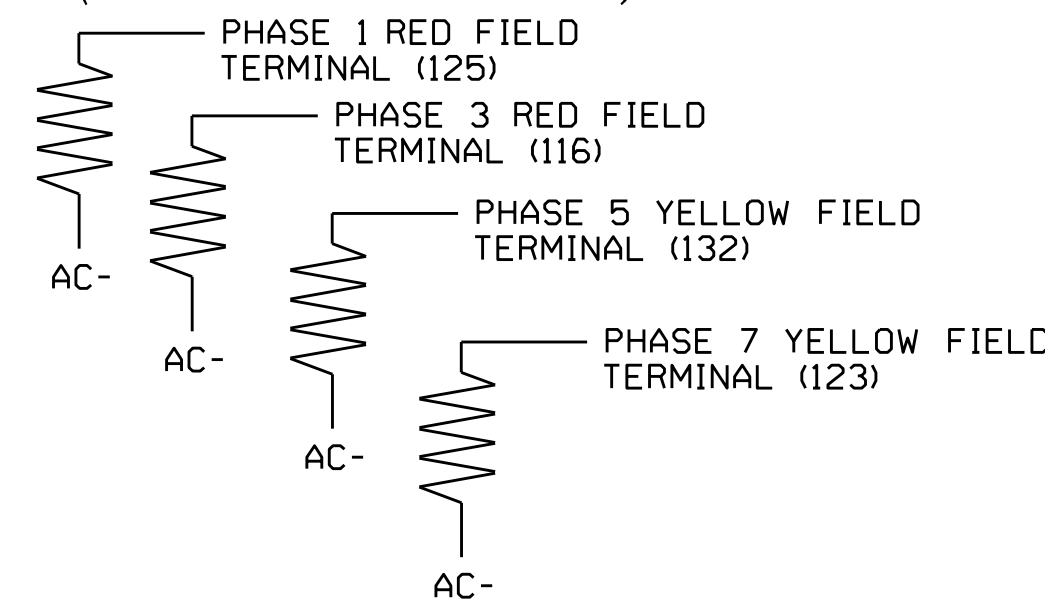

VALUE (ohms)	WATTAGE
1.5K - 1.9K	25W (min)
2.0K - 3.0K	10W (min)

Electrical Detail - Sheet 1 of 5

Electrical and Programming Details For:
 Prepared For:

 750 N. Greenfield Pkwy, Garner, NC 27529

NC 54 (S. Miami Boulevard) at SR 1978 (Hopson Road) / SR 1973 (Page Road)
 Division 5 Durham County Durham
 PLAN DATE: July 2025 REVIEWED BY:
 PREPARED BY: S.Kirkpatrick REVIEWED BY:
 REVISIONS INIT. DATE

DOCUMENT NOT CONSIDERED FINAL UNLESS ALL SIGNATURES COMPLETED
 SEAL
 NORTH CAROLINA PROFESSIONAL ENGINEER
 SEAL 036833
 RYAN W. HOUGH
 Signed by: Ryan W. Hough 08/11/2025
 430320FAA2854C3 DATE
 SIG. INVENTORY NO. 05-2008T3

ECONOLITE ASC/3-2070 VEHICLE DETECTOR SETUP PROGRAMMING DETAIL FOR ALTERNATE PHASING LOOPS 1A, 5A, 3A, 7A

(program controller as shown)

IMPORTANT!

Program detectors per the input file connection and programming chart shown on sheet 1 before proceeding.

1. From Main Menu select **8. UTILITIES**
2. From UTILITIES Submenu select **1. COPY/CLEAR**
3. Copy from DETECTOR PLAN "1" to DETECTOR PLAN "2".

```

COPY / CLEAR UTILITY
FROM          TO
PHASE TIMING... > PHASE TIMING...
TIMING PLAN... > TIMING PLAN...
PH DET OPT PLAN... > PH DET OPT PLAN...
DETECTOR PLAN... 1 > DETECTOR PLAN... 2
TOGGLE TO SELECT A "FROM" AND A "TO"
THEN PRESS ENTER
    
```

4. From Main Menu select **6. DETECTORS**
5. From DETECTOR Submenu select **2. VEHICLE DETECTOR SETUP**
6. Place cursor in VEH DET PLAN [] position and enter "2".

- Place cursor in VEH DETECTOR [] position and enter "1".
- Set delay time to "3".

```

VEH DETECTOR [ 1]  VEH DET PLAN [ 2]
TYPE: S-STANDARD
TS2 DETECTOR..... ECPI LOG..... NO
DET PH - 1 2 3 4 5 6 7 8 9 0 1 2 3 4 5 6
1 1 .....
EXTEND TIME... 0.0 DELAY TIME... 3.0
USE ADDED INITIAL . CROSS SWITCH PH.. 0
LOCK IN..... NONE NTCIP VOL . OR OCC .
PMT QUEUE DELAY. NO
    
```

- Place cursor in VEH DETECTOR [] position and enter "26".
- Set assigned phase to "0".

```

VEH DETECTOR [26]  VEH DET PLAN [ 2]
TYPE: G-GREEN EXTENSION/DELAY
TS2 DETECTOR..... ECPI LOG..... NO
DET PH - 1 2 3 4 5 6 7 8 9 0 1 2 3 4 5 6
26 0 .....
EXTEND TIME... 0.0 DELAY TIME... 3.0
USE ADDED INITIAL . CROSS SWITCH PH.. 0
LOCK IN..... NONE NTCIP VOL . OR OCC .
PMT QUEUE DELAY. NO
    
```

- Place cursor in VEH DETECTOR [] position and enter "5".
- Set delay time to "3".

```

VEH DETECTOR [ 5]  VEH DET PLAN [ 2]
TYPE: S-STANDARD
TS2 DETECTOR..... ECPI LOG..... NO
DET PH - 1 2 3 4 5 6 7 8 9 0 1 2 3 4 5 6
5 5 .....
EXTEND TIME... 0.0 DELAY TIME... 3.0
USE ADDED INITIAL . CROSS SWITCH PH.. 0
LOCK IN..... NONE NTCIP VOL . OR OCC .
PMT QUEUE DELAY. NO
    
```

- Place cursor in VEH DETECTOR [] position and enter "22".
- Set assigned phase to "0".

```

VEH DETECTOR [22]  VEH DET PLAN [ 2]
TYPE: G-GREEN EXTENSION/DELAY
TS2 DETECTOR..... ECPI LOG..... NO
DET PH - 1 2 3 4 5 6 7 8 9 0 1 2 3 4 5 6
22 0 .....
EXTEND TIME... 0.0 DELAY TIME... 3.0
USE ADDED INITIAL . CROSS SWITCH PH.. 0
LOCK IN..... NONE NTCIP VOL . OR OCC .
PMT QUEUE DELAY. NO
    
```

- Place cursor in VEH DETECTOR [] position and enter "3".
- Set delay time to "0".

```

VEH DETECTOR [ 3]  VEH DET PLAN [ 2]
TYPE: S-STANDARD
TS2 DETECTOR..... ECPI LOG..... NO
DET PH - 1 2 3 4 5 6 7 8 9 0 1 2 3 4 5 6
3 3 .....
EXTEND TIME... 0.0 DELAY TIME... 0.0
USE ADDED INITIAL . CROSS SWITCH PH.. 0
LOCK IN..... NONE NTCIP VOL . OR OCC .
PMT QUEUE DELAY. NO
    
```

- Place cursor in VEH DETECTOR [] position and enter "28".
- Set assigned phase to "0".

```

VEH DETECTOR [28]  VEH DET PLAN [ 2]
TYPE: S-STANDARD
TS2 DETECTOR..... ECPI LOG..... NO
DET PH - 1 2 3 4 5 6 7 8 9 0 1 2 3 4 5 6
28 0 .....
EXTEND TIME... 0.0 DELAY TIME... 0.0
USE ADDED INITIAL . CROSS SWITCH PH.. 0
LOCK IN..... NONE NTCIP VOL . OR OCC .
PMT QUEUE DELAY. NO
    
```

- Place cursor in VEH DETECTOR [] position and enter "7".
- Set delay time to "0".

```

VEH DETECTOR [ 7]  VEH DET PLAN [ 2]
TYPE: S-STANDARD
TS2 DETECTOR..... ECPI LOG..... NO
DET PH - 1 2 3 4 5 6 7 8 9 0 1 2 3 4 5 6
7 7 .....
EXTEND TIME... 0.0 DELAY TIME... 0.0
USE ADDED INITIAL . CROSS SWITCH PH.. 0
LOCK IN..... NONE NTCIP VOL . OR OCC .
PMT QUEUE DELAY. NO
    
```

- Place cursor in VEH DETECTOR [] position and enter "24".
- Set assigned phase to "0".

```

VEH DETECTOR [24]  VEH DET PLAN [ 2]
TYPE: S-STANDARD
TS2 DETECTOR..... ECPI LOG..... NO
DET PH - 1 2 3 4 5 6 7 8 9 0 1 2 3 4 5 6
24 0 .....
EXTEND TIME... 0.0 DELAY TIME... 0.0
USE ADDED INITIAL . CROSS SWITCH PH.. 0
LOCK IN..... NONE NTCIP VOL . OR OCC .
PMT QUEUE DELAY. NO
    
```

END PROGRAMMING

I:\AUG-2025_11:45 D:\ncdot-pw-bentley.com\ncdot-pw-01\Documents\NCDOT_TSMO\Signal Design\Signal Design\05-005-2008\Signal Management\052008-sm.ele_20250811.dgn

Electrical Detail - Sheet 2 of 5

DOCUMENT NOT CONSIDERED FINAL UNLESS ALL SIGNATURES COMPLETED

THIS ELECTRICAL DETAIL IS FOR THE SIGNAL DESIGN: 05-2008
DESIGN: April 2025
SEALED: 08/11/2025
REVISED: N/A

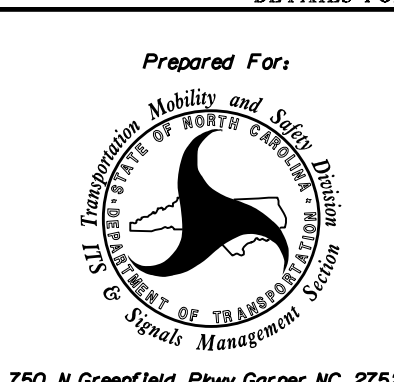
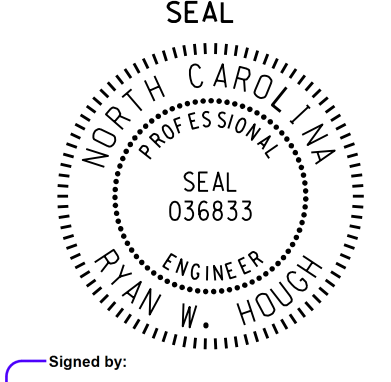
 <p>750 N. Greenfield Pkwy, Garner, NC 27529</p>	<p>NC 54 (S. Miami Boulevard) at SR 1978 (Hopson Road) / SR 1973 (Page Road)</p> <p>Division 5 Durham County Durham</p> <p>PLAN DATE: July 2025 REVIEWED BY:</p> <p>PREPARED BY: S. Kirkpatrick REVIEWED BY:</p> <table border="1" style="width: 100%; border-collapse: collapse;"> <thead> <tr> <th>REVISIONS</th> <th>INIT.</th> <th>DATE</th> </tr> </thead> <tbody> <tr> <td> </td> <td> </td> <td> </td> </tr> </tbody> </table>	REVISIONS	INIT.	DATE				<p>SEAL</p>  <p>Signed by: Ryan W. Hough 08/11/2025 DATE</p> <p>SIG. INVENTORY NO. 05-2008</p>
REVISIONS	INIT.	DATE						

ECONOLITE ASC/3-2070 VEHICLE DETECTOR SETUP PROGRAMMING DETAIL FOR ALTERNATE PHASING LOOPS 1A, 5A, 3A, 7A

(program controller as shown)

IMPORTANT!

Program detectors per the input file connection and programming chart shown on sheet 1 before proceeding.

1. From Main Menu select **8. UTILITIES**
2. From UTILITIES Submenu select **1. COPY/CLEAR**
3. Copy from DETECTOR PLAN "1" to DETECTOR PLAN "2".

```

COPY / CLEAR UTILITY
FROM          TO
PHASE TIMING... > PHASE TIMING...
TIMING PLAN... > TIMING PLAN...
PH DET OPT PLAN... > PH DET OPT PLAN...
DETECTOR PLAN... 1 > DETECTOR PLAN... 2
TOGGLE TO SELECT A "FROM" AND A "TO"
THEN PRESS ENTER
    
```

4. From Main Menu select **6. DETECTORS**
5. From DETECTOR Submenu select **2. VEHICLE DETECTOR SETUP**
6. Place cursor in VEH DET PLAN [] position and enter "2".

- Place cursor in VEH DETECTOR [] position and enter "1".
- Set delay time to "3".

```

VEH DETECTOR [ 1]  VEH DET PLAN [ 2]
TYPE: S-STANDARD
TS2 DETECTOR..... ECPI LOG..... NO
DET PH - 1 2 3 4 5 6 7 8 9 0 1 2 3 4 5 6
1 1
EXTEND TIME... 0.0 DELAY TIME... 3.0
USE ADDED INITIAL . CROSS SWITCH PH.. 0
LOCK IN..... NONE NTCIP VOL . OR OCC .
PMT QUEUE DELAY. NO
    
```

- Place cursor in VEH DETECTOR [] position and enter "26".
- Set assigned phase to "0".

```

VEH DETECTOR [26]  VEH DET PLAN [ 2]
TYPE: G-GREEN EXTENSION/DELAY
TS2 DETECTOR..... ECPI LOG..... NO
DET PH - 1 2 3 4 5 6 7 8 9 0 1 2 3 4 5 6
26 0
EXTEND TIME... 0.0 DELAY TIME... 3.0
USE ADDED INITIAL . CROSS SWITCH PH.. 0
LOCK IN..... NONE NTCIP VOL . OR OCC .
PMT QUEUE DELAY. NO
    
```

- Place cursor in VEH DETECTOR [] position and enter "5".
- Set delay time to "3".

```

VEH DETECTOR [ 5]  VEH DET PLAN [ 2]
TYPE: S-STANDARD
TS2 DETECTOR..... ECPI LOG..... NO
DET PH - 1 2 3 4 5 6 7 8 9 0 1 2 3 4 5 6
5 5
EXTEND TIME... 0.0 DELAY TIME... 3.0
USE ADDED INITIAL . CROSS SWITCH PH.. 0
LOCK IN..... NONE NTCIP VOL . OR OCC .
PMT QUEUE DELAY. NO
    
```

- Place cursor in VEH DETECTOR [] position and enter "22".
- Set assigned phase to "0".

```

VEH DETECTOR [22]  VEH DET PLAN [ 2]
TYPE: G-GREEN EXTENSION/DELAY
TS2 DETECTOR..... ECPI LOG..... NO
DET PH - 1 2 3 4 5 6 7 8 9 0 1 2 3 4 5 6
22 0
EXTEND TIME... 0.0 DELAY TIME... 3.0
USE ADDED INITIAL . CROSS SWITCH PH.. 0
LOCK IN..... NONE NTCIP VOL . OR OCC .
PMT QUEUE DELAY. NO
    
```

- Place cursor in VEH DETECTOR [] position and enter "3".
- Set delay time to "0".

```

VEH DETECTOR [ 3]  VEH DET PLAN [ 2]
TYPE: S-STANDARD
TS2 DETECTOR..... ECPI LOG..... NO
DET PH - 1 2 3 4 5 6 7 8 9 0 1 2 3 4 5 6
3 3
EXTEND TIME... 0.0 DELAY TIME... 0.0
USE ADDED INITIAL . CROSS SWITCH PH.. 0
LOCK IN..... NONE NTCIP VOL . OR OCC .
PMT QUEUE DELAY. NO
    
```

- Place cursor in VEH DETECTOR [] position and enter "28".
- Set assigned phase to "0".

```

VEH DETECTOR [28]  VEH DET PLAN [ 2]
TYPE: S-STANDARD
TS2 DETECTOR..... ECPI LOG..... NO
DET PH - 1 2 3 4 5 6 7 8 9 0 1 2 3 4 5 6
28 0
EXTEND TIME... 0.0 DELAY TIME... 0.0
USE ADDED INITIAL . CROSS SWITCH PH.. 0
LOCK IN..... NONE NTCIP VOL . OR OCC .
PMT QUEUE DELAY. NO
    
```

- Place cursor in VEH DETECTOR [] position and enter "7".
- Set delay time to "0".

```

VEH DETECTOR [ 7]  VEH DET PLAN [ 2]
TYPE: S-STANDARD
TS2 DETECTOR..... ECPI LOG..... NO
DET PH - 1 2 3 4 5 6 7 8 9 0 1 2 3 4 5 6
7 7
EXTEND TIME... 0.0 DELAY TIME... 0.0
USE ADDED INITIAL . CROSS SWITCH PH.. 0
LOCK IN..... NONE NTCIP VOL . OR OCC .
PMT QUEUE DELAY. NO
    
```

- Place cursor in VEH DETECTOR [] position and enter "24".
- Set assigned phase to "0".

```

VEH DETECTOR [24]  VEH DET PLAN [ 2]
TYPE: S-STANDARD
TS2 DETECTOR..... ECPI LOG..... NO
DET PH - 1 2 3 4 5 6 7 8 9 0 1 2 3 4 5 6
24 0
EXTEND TIME... 0.0 DELAY TIME... 0.0
USE ADDED INITIAL . CROSS SWITCH PH.. 0
LOCK IN..... NONE NTCIP VOL . OR OCC .
PMT QUEUE DELAY. NO
    
```

END PROGRAMMING

I:\AUG-2025_11:22
 D:\ncdot-pw-bentley.com\ncdot-pw-01\Documents\NCDOT_TSMO\SIGNAL Design\01\Signal Management\052008T1.sm.le.20250811.dgn
 sgm:lr:pc:tr:ck

THIS ELECTRICAL DETAIL IS FOR
 THE SIGNAL DESIGN: 05-2008T1
 DESIGN: June 2025
 SEALED: 08/11/2025
 REVISED: N/A

Electrical Detail - Sheet 2 of 5

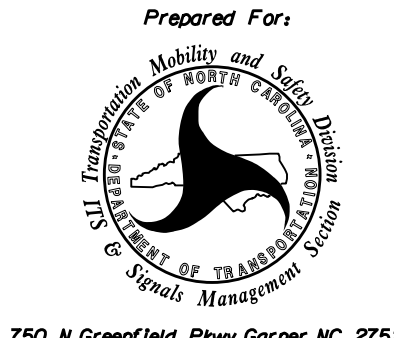
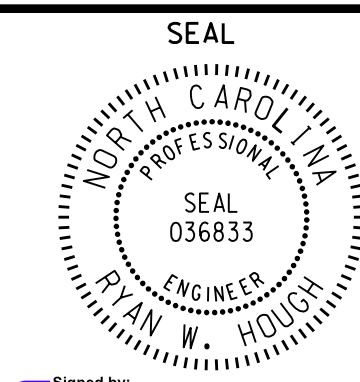
ELECTRICAL AND PROGRAMMING DETAILS FOR:	NC 54 (S. Miami Boulevard) at SR 1978 (Hopson Road)/ SR 1973 (Page Road)	DOCUMENT NOT CONSIDERED FINAL UNLESS ALL SIGNATURES COMPLETED
Prepared For:  750 N. Greenfield Pkwy, Garner, NC 27529	Division 5 Durham County Durham PLAN DATE: July 2025 REVIEWED BY: PREPARED BY: S. Kirkpatrick REVIEWED BY:	SEAL  Ryan W. Hough ENGINEER SEAL 036833
REVISIONS		SIGNED BY: Ryan W. Hough 08/11/2025 DATE:
INVENTORY NO. 05-2008T1		

ECONOLITE ASC/3-2070 VEHICLE DETECTOR SETUP PROGRAMMING DETAIL FOR ALTERNATE PHASING LOOPS 1A, 5A, 3A, 7A

(program controller as shown)

IMPORTANT!

Program detectors per the input file connection and programming chart shown on sheet 1 before proceeding.

1. From Main Menu select 8. UTILITIES
2. From UTILITIES Submenu select 1. COPY/CLEAR
3. Copy from DETECTOR PLAN "1" to DETECTOR PLAN "2".

COPY / CLEAR UTILITY
FROM TO
PHASE TIMING.... > PHASE TIMING....
TIMING PLAN.... > TIMING PLAN....
PH DET OPT PLAN.. > PH DET OPT PLAN..
DETECTOR PLAN.. 1 > DETECTOR PLAN.. 2
TOGGLE TO SELECT A "FROM" AND A "TO"
THEN PRESS ENTER

4. From Main Menu select 6. DETECTORS
5. From DETECTOR Submenu select 2. VEHICLE DETECTOR SETUP
6. Place cursor in VEH DET PLAN [] position and enter "2".

- Place cursor in VEH DETECTOR [] position and enter "1".
- Set delay time to "3".

```

VEH DETECTOR [ 1]  VEH DET PLAN [ 2]
TYPE: S-STANDARD
TS2 DETECTOR..... ECPI LOG..... NO
DET PH - 1 2 3 4 5 6 7 8 9 0 1 2 3 4 5 6
1 1 .....
EXTEND TIME... 0.0 DELAY TIME... 3.0
USE ADDED INITIAL . CROSS SWITCH PH.. 0
LOCK IN..... NONE NTCIP VOL . OR OCC .
PMT QUEUE DELAY. NO
    
```

- Place cursor in VEH DETECTOR [] position and enter "26".
- Set assigned phase to "0".

```

VEH DETECTOR [26]  VEH DET PLAN [ 2]
TYPE: G-GREEN EXTENSION/DELAY
TS2 DETECTOR..... ECPI LOG..... NO
DET PH - 1 2 3 4 5 6 7 8 9 0 1 2 3 4 5 6
26 0 .....
EXTEND TIME... 0.0 DELAY TIME... 3.0
USE ADDED INITIAL . CROSS SWITCH PH.. 0
LOCK IN..... NONE NTCIP VOL . OR OCC .
PMT QUEUE DELAY. NO
    
```

- Place cursor in VEH DETECTOR [] position and enter "5".
- Set delay time to "3".

```

VEH DETECTOR [ 5]  VEH DET PLAN [ 2]
TYPE: S-STANDARD
TS2 DETECTOR..... ECPI LOG..... NO
DET PH - 1 2 3 4 5 6 7 8 9 0 1 2 3 4 5 6
5 5 .....
EXTEND TIME... 0.0 DELAY TIME... 3.0
USE ADDED INITIAL . CROSS SWITCH PH.. 0
LOCK IN..... NONE NTCIP VOL . OR OCC .
PMT QUEUE DELAY. NO
    
```

- Place cursor in VEH DETECTOR [] position and enter "22".
- Set assigned phase to "0".

```

VEH DETECTOR [22]  VEH DET PLAN [ 2]
TYPE: G-GREEN EXTENSION/DELAY
TS2 DETECTOR..... ECPI LOG..... NO
DET PH - 1 2 3 4 5 6 7 8 9 0 1 2 3 4 5 6
22 0 .....
EXTEND TIME... 0.0 DELAY TIME... 3.0
USE ADDED INITIAL . CROSS SWITCH PH.. 0
LOCK IN..... NONE NTCIP VOL . OR OCC .
PMT QUEUE DELAY. NO
    
```

- Place cursor in VEH DETECTOR [] position and enter "3".
- Set delay time to "0".

```

VEH DETECTOR [ 3]  VEH DET PLAN [ 2]
TYPE: S-STANDARD
TS2 DETECTOR..... ECPI LOG..... NO
DET PH - 1 2 3 4 5 6 7 8 9 0 1 2 3 4 5 6
3 3 .....
EXTEND TIME... 0.0 DELAY TIME... 0.0
USE ADDED INITIAL . CROSS SWITCH PH.. 0
LOCK IN..... NONE NTCIP VOL . OR OCC .
PMT QUEUE DELAY. NO
    
```

- Place cursor in VEH DETECTOR [] position and enter "28".
- Set assigned phase to "0".

```

VEH DETECTOR [28]  VEH DET PLAN [ 2]
TYPE: S-STANDARD
TS2 DETECTOR..... ECPI LOG..... NO
DET PH - 1 2 3 4 5 6 7 8 9 0 1 2 3 4 5 6
28 0 .....
EXTEND TIME... 0.0 DELAY TIME... 0.0
USE ADDED INITIAL . CROSS SWITCH PH.. 0
LOCK IN..... NONE NTCIP VOL . OR OCC .
PMT QUEUE DELAY. NO
    
```

- Place cursor in VEH DETECTOR [] position and enter "7".
- Set delay time to "0".

```

VEH DETECTOR [ 7]  VEH DET PLAN [ 2]
TYPE: S-STANDARD
TS2 DETECTOR..... ECPI LOG..... NO
DET PH - 1 2 3 4 5 6 7 8 9 0 1 2 3 4 5 6
7 7 .....
EXTEND TIME... 0.0 DELAY TIME... 0.0
USE ADDED INITIAL . CROSS SWITCH PH.. 0
LOCK IN..... NONE NTCIP VOL . OR OCC .
PMT QUEUE DELAY. NO
    
```

- Place cursor in VEH DETECTOR [] position and enter "24".
- Set assigned phase to "0".

```

VEH DETECTOR [24]  VEH DET PLAN [ 2]
TYPE: S-STANDARD
TS2 DETECTOR..... ECPI LOG..... NO
DET PH - 1 2 3 4 5 6 7 8 9 0 1 2 3 4 5 6
24 0 .....
EXTEND TIME... 0.0 DELAY TIME... 0.0
USE ADDED INITIAL . CROSS SWITCH PH.. 0
LOCK IN..... NONE NTCIP VOL . OR OCC .
PMT QUEUE DELAY. NO
    
```

END PROGRAMMING

ENSURE PHASE IS SET TO "0"

ENSURE PHASE IS SET TO "0"

ENSURE PHASE IS SET TO "0"

I:\AUG-2025 11:29 D:\ncdot-pw\ben\key_comp\ncdot-pw-01\Documents\ACDOT_TSMO\SIGNAL Design\01\14\Signal_Mgmt\05-05-2008\Signal_Management\052008T2_sm.ele_20250811.dgn
 sig.rpt:rick

THIS ELECTRICAL DETAIL IS FOR
THE SIGNAL DESIGN: 05-2008T2
DESIGN: June 2025
SEALED: 08/11/2025
REVISED: N/A

Electrical Detail - Sheet 2 of 5

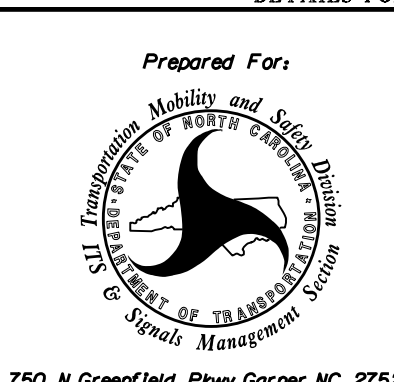
Prepared For:

750 N. Greenfield Pkwy, Garner, NC 27529

DOCUMENT NOT CONSIDERED FINAL UNLESS ALL SIGNATURES COMPLETED

NC 54 (S. Miami Boulevard)
at
SR 1978 (Hopson Road)/
SR 1973 (Page Road)

Division 5 Durham County Durham

PLAN DATE: July 2025 REVIEWED BY:
PREPARED BY: S. Kirkpatrick REVIEWED BY:

REVISIONS	INIT.	DATE

Signed by:
 08/11/2025
430300FA268563 DATE
SIG. INVENTORY NO. 05-2008T2

ECONOLITE ASC/3-2070 VEHICLE DETECTOR SETUP PROGRAMMING DETAIL FOR ALTERNATE PHASING LOOPS 1A, 5A, 3A, 7A

(program controller as shown)

IMPORTANT!

Program detectors per the input file connection and programming chart shown on sheet 1 before proceeding.

1. From Main Menu select **8. UTILITIES**
2. From UTILITIES Submenu select **1. COPY/CLEAR**
3. Copy from DETECTOR PLAN "1" to DETECTOR PLAN "2".

```

COPY / CLEAR UTILITY
FROM          TO
PHASE TIMING... > PHASE TIMING...
TIMING PLAN... > TIMING PLAN...
PH DET OPT PLAN... > PH DET OPT PLAN...
DETECTOR PLAN.. 1 > DETECTOR PLAN.. 2
TOGGLE TO SELECT A "FROM" AND A "TO"
THEN PRESS ENTER
    
```

4. From Main Menu select **6. DETECTORS**
5. From DETECTOR Submenu select **2. VEHICLE DETECTOR SETUP**
6. Place cursor in VEH DET PLAN [] position and enter "2".

- Place cursor in VEH DETECTOR [] position and enter "1".
- Set delay time to "3".

```

VEH DETECTOR [ 1]  VEH DET PLAN [ 2]
TYPE: S-STANDARD
TS2 DETECTOR..... ECPI LOG..... NO
DET PH - 1 2 3 4 5 6 7 8 9 0 1 2 3 4 5 6
1 1 .....
EXTEND TIME... 0.0 DELAY TIME... 3.0
USE ADDED INITIAL . CROSS SWITCH PH.. 0
LOCK IN..... NONE NTCIP VOL . OR OCC .
PMT QUEUE DELAY. NO
    
```

- Place cursor in VEH DETECTOR [] position and enter "26".
- Set assigned phase to "0".

```

VEH DETECTOR [26]  VEH DET PLAN [ 2]
TYPE: G-GREEN EXTENSION/DELAY
TS2 DETECTOR..... ECPI LOG..... NO
DET PH - 1 2 3 4 5 6 7 8 9 0 1 2 3 4 5 6
26 0 .....
EXTEND TIME... 0.0 DELAY TIME... 3.0
USE ADDED INITIAL . CROSS SWITCH PH.. 0
LOCK IN..... NONE NTCIP VOL . OR OCC .
PMT QUEUE DELAY. NO
    
```

- Place cursor in VEH DETECTOR [] position and enter "5".
- Set delay time to "3".

```

VEH DETECTOR [ 5]  VEH DET PLAN [ 2]
TYPE: S-STANDARD
TS2 DETECTOR..... ECPI LOG..... NO
DET PH - 1 2 3 4 5 6 7 8 9 0 1 2 3 4 5 6
5 5 .....
EXTEND TIME... 0.0 DELAY TIME... 3.0
USE ADDED INITIAL . CROSS SWITCH PH.. 0
LOCK IN..... NONE NTCIP VOL . OR OCC .
PMT QUEUE DELAY. NO
    
```

- Place cursor in VEH DETECTOR [] position and enter "22".
- Set assigned phase to "0".

```

VEH DETECTOR [22]  VEH DET PLAN [ 2]
TYPE: G-GREEN EXTENSION/DELAY
TS2 DETECTOR..... ECPI LOG..... NO
DET PH - 1 2 3 4 5 6 7 8 9 0 1 2 3 4 5 6
22 0 .....
EXTEND TIME... 0.0 DELAY TIME... 3.0
USE ADDED INITIAL . CROSS SWITCH PH.. 0
LOCK IN..... NONE NTCIP VOL . OR OCC .
PMT QUEUE DELAY. NO
    
```

- Place cursor in VEH DETECTOR [] position and enter "3".
- Set delay time to "0".

```

VEH DETECTOR [ 3]  VEH DET PLAN [ 2]
TYPE: S-STANDARD
TS2 DETECTOR..... ECPI LOG..... NO
DET PH - 1 2 3 4 5 6 7 8 9 0 1 2 3 4 5 6
3 3 .....
EXTEND TIME... 0.0 DELAY TIME... 0.0
USE ADDED INITIAL . CROSS SWITCH PH.. 0
LOCK IN..... NONE NTCIP VOL . OR OCC .
PMT QUEUE DELAY. NO
    
```

- Place cursor in VEH DETECTOR [] position and enter "28".
- Set assigned phase to "0".

```

VEH DETECTOR [28]  VEH DET PLAN [ 2]
TYPE: S-STANDARD
TS2 DETECTOR..... ECPI LOG..... NO
DET PH - 1 2 3 4 5 6 7 8 9 0 1 2 3 4 5 6
28 0 .....
EXTEND TIME... 0.0 DELAY TIME... 0.0
USE ADDED INITIAL . CROSS SWITCH PH.. 0
LOCK IN..... NONE NTCIP VOL . OR OCC .
PMT QUEUE DELAY. NO
    
```

- Place cursor in VEH DETECTOR [] position and enter "7".
- Set delay time to "0".

```

VEH DETECTOR [ 7]  VEH DET PLAN [ 2]
TYPE: S-STANDARD
TS2 DETECTOR..... ECPI LOG..... NO
DET PH - 1 2 3 4 5 6 7 8 9 0 1 2 3 4 5 6
7 7 .....
EXTEND TIME... 0.0 DELAY TIME... 0.0
USE ADDED INITIAL . CROSS SWITCH PH.. 0
LOCK IN..... NONE NTCIP VOL . OR OCC .
PMT QUEUE DELAY. NO
    
```

- Place cursor in VEH DETECTOR [] position and enter "24".
- Set assigned phase to "0".

```

VEH DETECTOR [24]  VEH DET PLAN [ 2]
TYPE: S-STANDARD
TS2 DETECTOR..... ECPI LOG..... NO
DET PH - 1 2 3 4 5 6 7 8 9 0 1 2 3 4 5 6
24 0 .....
EXTEND TIME... 0.0 DELAY TIME... 0.0
USE ADDED INITIAL . CROSS SWITCH PH.. 0
LOCK IN..... NONE NTCIP VOL . OR OCC .
PMT QUEUE DELAY. NO
    
```

END PROGRAMMING

I:\AUG-2025_11:37
 p:\r\ncdot-pw\ben\ley.com\ncdot-pw-01\Documents\NCDOT_TSMO\SIGNAL Design\Sect1\an01\vision_05-05-2008\SIGNALS Management\052008T3.sm.le.20250811.dgn
 sig.r.rpt:ck

THIS ELECTRICAL DETAIL IS FOR
 THE SIGNAL DESIGN: 05-2008T3
 DESIGN: June 2025
 SEALED: 08/11/2025
 REVISED: N/A

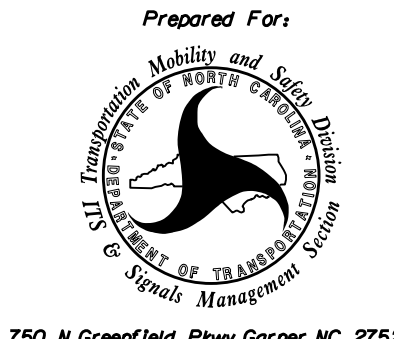
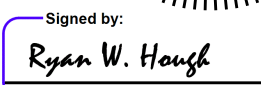
Electrical Detail - Sheet 2 of 5		DOCUMENT NOT CONSIDERED FINAL UNLESS ALL SIGNATURES COMPLETED	
ELECTRICAL AND PROGRAMMING DETAILS FOR:	NC 54 (S. Miami Boulevard) at SR 1978 (Hopson Road)/ SR 1973 (Page Road)		
Prepared For: 	Division 5 Durham County Durham		
PLAN DATE: July 2025	REVIEWED BY:		
PREPARED BY: S.Kirkpatrick		REVIEWED BY:	
REVISIONS	INIT.	DATE	
Signed by: 		08/11/2025	
SEAL NORTH CAROLINA PROFESSIONAL ENGINEER RYAN W. HAUGH		SEAL 036833	
750 N. Greenfield Pkwy, Garner, NC 27529		430320FAA2654C3 DATE	
SIG. INVENTORY NO. 05-2008T3			

ECONOLITE ASC/3-2070 OVERLAP PROGRAMMING DETAIL

(program controller as shown)

- From Main Menu select **2. CONTROLLER**
- From CONTROLLER Submenu select **2. VEHICLE OVERLAPS**

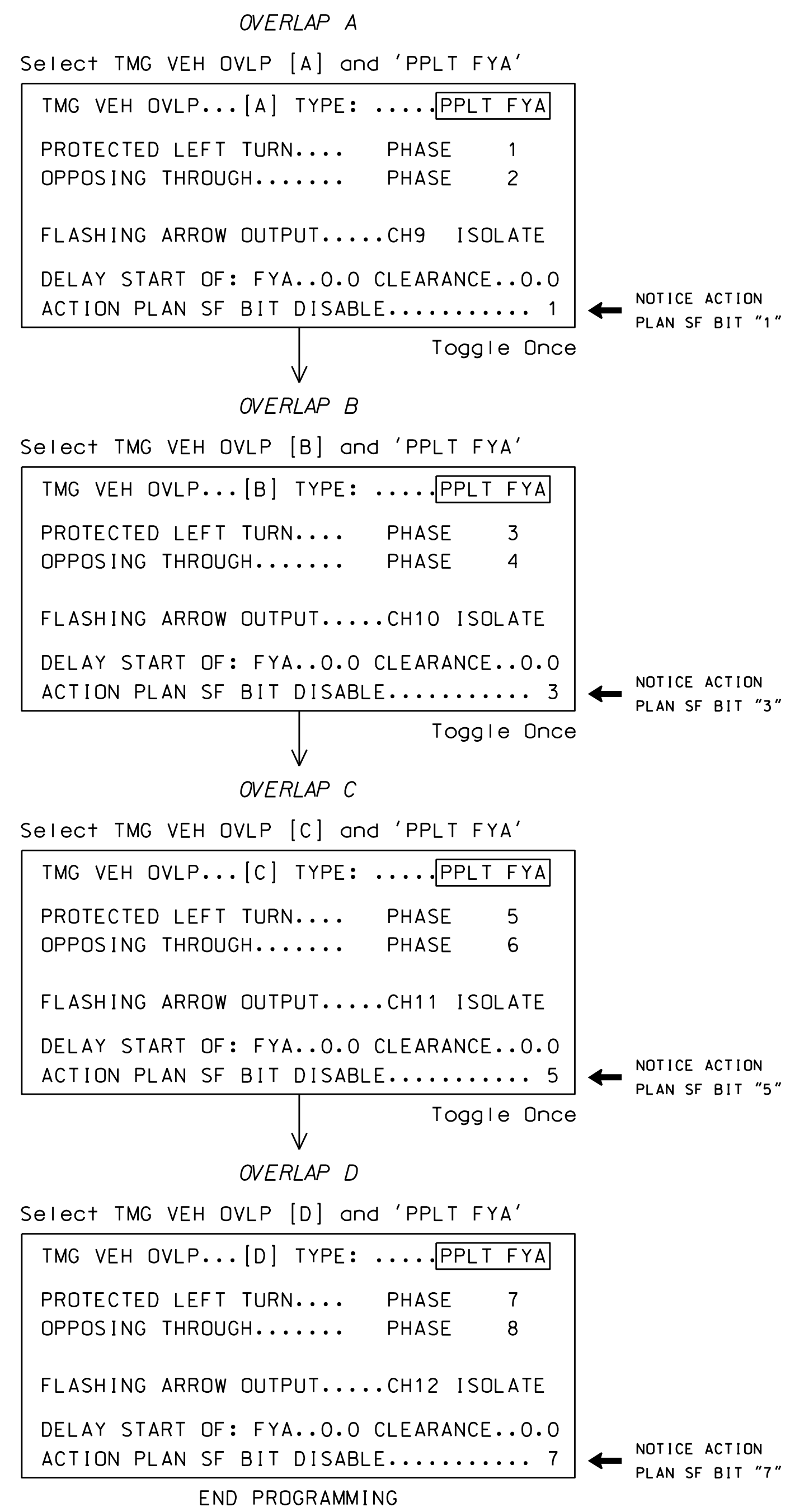

ECONOLITE ASC/3-2070 LOGIC PROCESSOR PROGRAMMING

(program controller as shown)

- From Main Menu select **1. CONFIGURATION**
- From CONFIGURATION Submenu select **8. LOGIC PROCESSOR**
- From the LOGIC PROCESSOR Submenu select **2. LOGIC STATEMENTS**

ENTER A "1" IN THE LP# FIELD. PRESS 'ENTER'. AND PROGRAM AS SHOWN.

```

LP#: 1 COPY FROM: 1 ACTIVE: M (T/F)
IF PED ON PH WALK 2 IS ON
AND VEH GREEN ON PH 2 IS OFF

THEN SIG SET OLP RED 1 ON
SIG SET OLP YELLOW 1 OFF
SIG SET OVLP GREEN 1 OFF

ELSE
    
```

HOLD SIGNAL HEAD 51 FYA RED DURING THE PHASE 6 DELAYED GREEN TIME (LEADING PED INTERVAL)

ENTER A "2" IN THE LP# FIELD. PRESS 'ENTER'. AND PROGRAM AS SHOWN.

```

LP#: 2 COPY FROM: 2 ACTIVE: M (T/F)
IF PED ON PH WALK 6 IS ON
AND VEH GREEN ON PH 6 IS OFF

THEN SIG SET OLP RED 3 ON
SIG SET OLP YELLOW 3 OFF
SIG SET OVLP GREEN 3 OFF

ELSE
    
```

HOLD SIGNAL HEAD 51 FYA RED DURING THE PHASE 6 DELAYED GREEN TIME (LEADING PED INTERVAL)

- From Main Menu select **1. CONFIGURATION**
- From CONFIGURATION Submenu select **8. LOGIC PROCESSOR**
- From the LOGIC PROCESSOR Submenu select **1. LOGIC STATEMENT CONTROL**

ENABLE LOGIC PROCESSOR STATEMENTS 1-2 BY POSITIONING THE CURSOR OVER THE FIELD SHOWN BELOW AND USING THE TOGGLE KEY TO ENABLE IT.

LOGIC STATEMENT CONTROL	1	2	3	4	5	6	7	8	9	0	1	2	3	4	5	6
LP 1-15	E	E
LP 16-30
LP 31-45
LP 46-60
LP 61-75
LP 76-90

END PROGRAMMING

THIS ELECTRICAL DETAIL IS FOR THE SIGNAL DESIGN: 05-2008
 DESIGN: April 2025
 SEALED: 08/11/2025
 REVISED: N/A

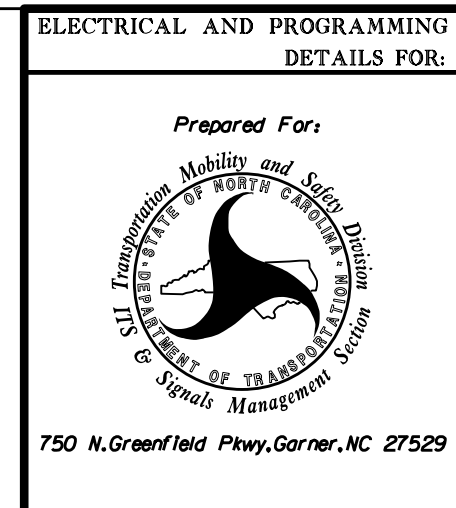

NC 54 (S. Miami Boulevard)
 at
 SR 1978 (Hopson Road)/
 SR 1973 (Page Road)

Division 5 Durham County Durham

PLAN DATE: July 2025 REVIEWED BY:

PREPARED BY: S.Kirkpatrick REVIEWED BY:

REVISIONS	INIT.	DATE

DOCUMENT NOT CONSIDERED FINAL UNLESS ALL SIGNATURES COMPLETED

SEAL
 NORTH CAROLINA PROFESSIONAL ENGINEER
 RYAN W. HOUGH
 SEAL 036833

Signed by: Ryan W. Hough 08/11/2025
 DATE

SIG. INVENTORY NO. 05-2008

I:\AUG-2025_11:45
 p:\r\ncdot-pw\ben\ey.com\ncdot-pw\01\Documents\NCDOT_TSMO\SIGNAL Design\Sect1\an01\vision_05\05-2008\SIGNALS Management\052008_sm.ele_20250811.dgn
 sgc.r.rp.rtc

ECONOLITE ASC/3-2070 OVERLAP PROGRAMMING DETAIL

(program controller as shown)

1. From Main Menu select 2. CONTROLLER
2. From CONTROLLER Submenu select 2. VEHICLE OVERLAPS

OVERLAP A

Select TMG VEH OVLP [A] and 'PPLT FYA'

TMG VEH OVLP...[A] TYPE:	PPLT FYA
PROTECTED LEFT TURN....	PHASE 1
OPPOSING THROUGH.....	PHASE 2
FLASHING ARROW OUTPUT.....CH9 ISOLATE	
DELAY START OF: FYA..0.0 CLEARANCE..0.0	
ACTION PLAN SF BIT DISABLE..... 1	

← NOTICE ACTION PLAN SF BIT "1"
Toggle Once

OVERLAP B

Select TMG VEH OVLP [B] and 'PPLT FYA'

TMG VEH OVLP...[B] TYPE:	PPLT FYA
PROTECTED LEFT TURN....	PHASE 3
OPPOSING THROUGH.....	PHASE 4
FLASHING ARROW OUTPUT.....CH10 ISOLATE	
DELAY START OF: FYA..0.0 CLEARANCE..0.0	
ACTION PLAN SF BIT DISABLE..... 3	

← NOTICE ACTION PLAN SF BIT "3"
Toggle Once

OVERLAP C

Select TMG VEH OVLP [C] and 'PPLT FYA'

TMG VEH OVLP...[C] TYPE:	PPLT FYA
PROTECTED LEFT TURN....	PHASE 5
OPPOSING THROUGH.....	PHASE 6
FLASHING ARROW OUTPUT.....CH11 ISOLATE	
DELAY START OF: FYA..0.0 CLEARANCE..0.0	
ACTION PLAN SF BIT DISABLE..... 5	

← NOTICE ACTION PLAN SF BIT "5"
Toggle Once

OVERLAP D

Select TMG VEH OVLP [D] and 'PPLT FYA'

TMG VEH OVLP...[D] TYPE:	PPLT FYA
PROTECTED LEFT TURN....	PHASE 7
OPPOSING THROUGH.....	PHASE 8
FLASHING ARROW OUTPUT.....CH12 ISOLATE	
DELAY START OF: FYA..0.0 CLEARANCE..0.0	
ACTION PLAN SF BIT DISABLE..... 7	

← NOTICE ACTION PLAN SF BIT "7"
END PROGRAMMING

ECONOLITE ASC/3-2070 LOGIC PROCESSOR PROGRAMMING

(program controller as shown)

1. From Main Menu select 1. CONFIGURATION
2. From CONFIGURATION Submenu select 8. LOGIC PROCESSOR
3. From the LOGIC PROCESSOR Submenu select 2. LOGIC STATEMENTS

ENTER A "1" IN THE LP# FIELD. PRESS 'ENTER'. AND PROGRAM AS SHOWN.

LP#:	1	COPY FROM:	1	ACTIVE:	M	(T/F)
IF	PED ON PH WALK		2	IS	ON	
AND	VEH GREEN ON PH		2	IS	OFF	
THEN	SIG SET OLP RED		1		ON	
	SIG SET OLP YELLOW		1		OFF	
	SIG SET OVLV GREEN		1		OFF	
ELSE						

HOLD SIGNAL HEAD 51 FYA
RED DURING THE PHASE 6
DELAYED GREEN TIME
(LEADING PED INTERVAL)

1. From Main Menu select 1. CONFIGURATION
2. From CONFIGURATION Submenu select 8. LOGIC PROCESSOR
3. From the LOGIC PROCESSOR Submenu select 1. LOGIC STATEMENT CONTROL

ENABLE LOGIC PROCESSOR STATEMENT 1 BY POSITIONING THE CURSOR OVER THE FIELD SHOWN BELOW AND USING THE TOGGLE KEY TO ENABLE IT.

LOGIC STATEMENT CONTROL																
	1	2	3	4	5	6	7	8	9	0	1	2	3	4	5	6
LP 1-15	E
LP 16-30
LP 31-45
LP 46-60
LP 61-75
LP 76-90

END PROGRAMMING

THIS ELECTRICAL DETAIL IS FOR
THE SIGNAL DESIGN: 05-2008T1
DESIGN: June 2025
SEALED: 08/11/2025
REVISED: N/A

Electrical Detail - Sheet 3 of 5

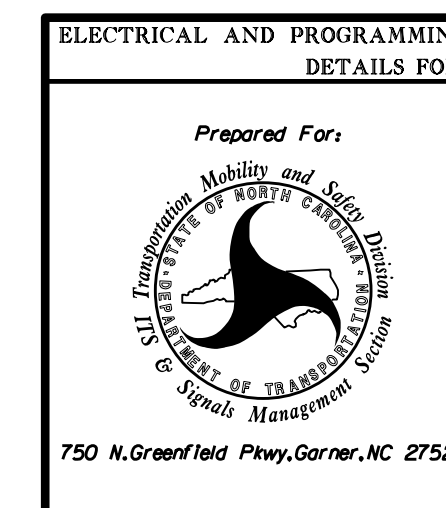

Prepared For:		NC 54 (S. Miami Boulevard) at SR 1978 (Hopson Road)/ SR 1973 (Page Road)	
Division 5		Durham County	
PLAN DATE:	July 2025	REVIEWED BY:	
PREPARED BY:	S. Kirkpatrick	REVIEWED BY:	
REVISIONS		INIT.	DATE

DOCUMENT NOT CONSIDERED FINAL UNLESS ALL SIGNATURES COMPLETED

	Signed by: Ryan W. Hough 08/11/2025 DATE
SIG. INVENTORY NO. 05-2008T1	

ECONOLITE ASC/3-2070 OVERLAP PROGRAMMING DETAIL

(program controller as shown)

1. From Main Menu select 2. CONTROLLER
2. From CONTROLLER Submenu select 2. VEHICLE OVERLAPS

OVERLAP A

Select TMG VEH OVLP [A] and 'PPLT FYA'

```

TMG VEH OVLP...[A] TYPE: ....[PPLT FYA]
PROTECTED LEFT TURN.... PHASE 1
OPPOSING THROUGH..... PHASE 2

FLASHING ARROW OUTPUT....CH9 ISOLATE
DELAY START OF: FYA..0.0 CLEARANCE..0.0
ACTION PLAN SF BIT DISABLE..... 1
    
```

← NOTICE ACTION
PLAN SF BIT "1"
Toggle Once

OVERLAP B

Select TMG VEH OVLP [B] and 'PPLT FYA'

```

TMG VEH OVLP...[B] TYPE: ....[PPLT FYA]
PROTECTED LEFT TURN.... PHASE 3
OPPOSING THROUGH..... PHASE 4

FLASHING ARROW OUTPUT....CH10 ISOLATE
DELAY START OF: FYA..0.0 CLEARANCE..0.0
ACTION PLAN SF BIT DISABLE..... 3
    
```

← NOTICE ACTION
PLAN SF BIT "3"
Toggle Once

OVERLAP C

Select TMG VEH OVLP [C] and 'PPLT FYA'

```

TMG VEH OVLP...[C] TYPE: ....[PPLT FYA]
PROTECTED LEFT TURN.... PHASE 5
OPPOSING THROUGH..... PHASE 6

FLASHING ARROW OUTPUT....CH11 ISOLATE
DELAY START OF: FYA..0.0 CLEARANCE..0.0
ACTION PLAN SF BIT DISABLE..... 5
    
```

← NOTICE ACTION
PLAN SF BIT "5"
Toggle Once

OVERLAP D

Select TMG VEH OVLP [D] and 'PPLT FYA'

```

TMG VEH OVLP...[D] TYPE: ....[PPLT FYA]
PROTECTED LEFT TURN.... PHASE 7
OPPOSING THROUGH..... PHASE 8

FLASHING ARROW OUTPUT....CH12 ISOLATE
DELAY START OF: FYA..0.0 CLEARANCE..0.0
ACTION PLAN SF BIT DISABLE..... 7
    
```

← NOTICE ACTION
PLAN SF BIT "7"
Toggle Once

END PROGRAMMING

ECONOLITE ASC/3-2070 LOGIC PROCESSOR PROGRAMMING

(program controller as shown)

1. From Main Menu select 1. CONFIGURATION
2. From CONFIGURATION Submenu select 8. LOGIC PROCESSOR
3. From the LOGIC PROCESSOR Submenu select 2. LOGIC STATEMENTS

ENTER A "1" IN THE LP# FIELD. PRESS 'ENTER'. AND PROGRAM AS SHOWN.

```

LP#: 1 COPY FROM: 1 ACTIVE: M (T/F)
IF PED ON PH WALK 2 IS ON
AND VEH GREEN ON PH 2 IS OFF

THEN SIG SET OLP RED 1 ON
SIG SET OLP YELLOW 1 OFF
SIG SET OVLV GREEN 1 OFF

ELSE
    
```

HOLD SIGNAL HEAD 51 FYA
RED DURING THE PHASE 6
DELAYED GREEN TIME
(LEADING PED INTERVAL)

1. From Main Menu select 1. CONFIGURATION
2. From CONFIGURATION Submenu select 8. LOGIC PROCESSOR
3. From the LOGIC PROCESSOR Submenu select 1. LOGIC STATEMENT CONTROL

ENABLE LOGIC PROCESSOR STATEMENT 1 BY POSITIONING THE CURSOR OVER THE FIELD SHOWN BELOW AND USING THE TOGGLE KEY TO ENABLE IT.

```

LOGIC STATEMENT CONTROL
      1 2 3 4 5 6 7 8 9 0 1 2 3 4 5 6
LP 1-15 E . . . . .
LP 16-30 . . . . .
LP 31-45 . . . . .
LP 46-60 . . . . .
LP 61-75 . . . . .
LP 76-90 . . . . .
    
```

END PROGRAMMING

THIS ELECTRICAL DETAIL IS FOR
THE SIGNAL DESIGN: 05-2008T2
DESIGN: June 2025
SEALED: 08/11/2025
REVISED: N/A

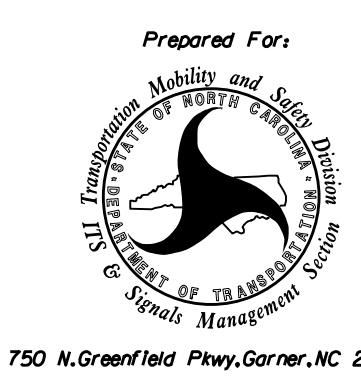
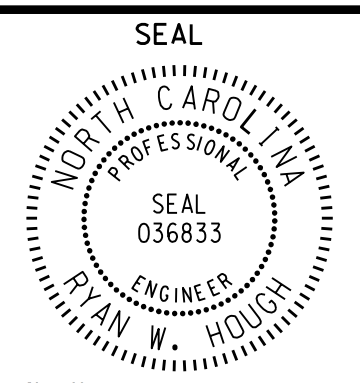
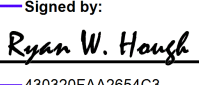
Electrical Detail - Sheet 3 of 5		DOCUMENT NOT CONSIDERED FINAL UNLESS ALL SIGNATURES COMPLETED	
	NC 54 (S. Miami Boulevard) at SR 1978 (Hopson Road)/ SR 1973 (Page Road)		SEAL 
	Division 5 Durham County Durham		Signed by:  08/11/2025 DATE
	PREPARED BY: S. Kirkpatrick REVIEWED BY:		
	REVISIONS	INIT. DATE	
750 N. Greenfield Pkwy, Garner, NC 27529		SIG. INVENTORY NO. 05-2008T2	

I:\1-AUG-2025 11:30 p:\r\ncdot-pw\benr\ey.com\ncdot-pw-01\Documents\NCDOT_TSMO\SIGNAL Design Sect1\ar\01\vision_05\05-2008\51signals_Management\052008T2_sm.le_20250811.dgn sgc.r.raptor.cck

ECONOLITE ASC/3-2070 OVERLAP PROGRAMMING DETAIL

(program controller as shown)

1. From Main Menu select 2. CONTROLLER
2. From CONTROLLER Submenu select 2. VEHICLE OVERLAPS

OVERLAP A

Select TMG VEH OVLP [A] and 'PPLT FYA'

TMG VEH OVLP...[A] TYPE:	PPLT FYA
PROTECTED LEFT TURN....	PHASE 1
OPPOSING THROUGH.....	PHASE 2
FLASHING ARROW OUTPUT.....CH9 ISOLATE	
DELAY START OF: FYA..0.0 CLEARANCE..0.0	
ACTION PLAN SF BIT DISABLE..... 1	

← NOTICE ACTION PLAN SF BIT "1"
Toggle Once

OVERLAP B

Select TMG VEH OVLP [B] and 'PPLT FYA'

TMG VEH OVLP...[B] TYPE:	PPLT FYA
PROTECTED LEFT TURN....	PHASE 3
OPPOSING THROUGH.....	PHASE 4
FLASHING ARROW OUTPUT.....CH10 ISOLATE	
DELAY START OF: FYA..0.0 CLEARANCE..0.0	
ACTION PLAN SF BIT DISABLE..... 3	

← NOTICE ACTION PLAN SF BIT "3"
Toggle Once

OVERLAP C

Select TMG VEH OVLP [C] and 'PPLT FYA'

TMG VEH OVLP...[C] TYPE:	PPLT FYA
PROTECTED LEFT TURN....	PHASE 5
OPPOSING THROUGH.....	PHASE 6
FLASHING ARROW OUTPUT.....CH11 ISOLATE	
DELAY START OF: FYA..0.0 CLEARANCE..0.0	
ACTION PLAN SF BIT DISABLE..... 5	

← NOTICE ACTION PLAN SF BIT "5"
Toggle Once

OVERLAP D

Select TMG VEH OVLP [D] and 'PPLT FYA'

TMG VEH OVLP...[D] TYPE:	PPLT FYA
PROTECTED LEFT TURN....	PHASE 7
OPPOSING THROUGH.....	PHASE 8
FLASHING ARROW OUTPUT.....CH12 ISOLATE	
DELAY START OF: FYA..0.0 CLEARANCE..0.0	
ACTION PLAN SF BIT DISABLE..... 7	

← NOTICE ACTION PLAN SF BIT "7"
END PROGRAMMING

ECONOLITE ASC/3-2070 LOGIC PROCESSOR PROGRAMMING

(program controller as shown)

1. From Main Menu select 1. CONFIGURATION
2. From CONFIGURATION Submenu select 8. LOGIC PROCESSOR
3. From the LOGIC PROCESSOR Submenu select 2. LOGIC STATEMENTS

ENTER A "1" IN THE LP# FIELD. PRESS 'ENTER'. AND PROGRAM AS SHOWN.

LP#:	1	COPY FROM:	1	ACTIVE:	M	(T/F)
IF	PED ON PH WALK		2	IS	ON	
AND	VEH GREEN ON PH		2	IS	OFF	
THEN	SIG SET OLP RED		1		ON	
	SIG SET OLP YELLOW		1		OFF	
	SIG SET OVLV GREEN		1		OFF	
ELSE						

HOLD SIGNAL HEAD 51 FYA RED DURING THE PHASE 6 DELAYED GREEN TIME (LEADING PED INTERVAL)

1. From Main Menu select 1. CONFIGURATION
2. From CONFIGURATION Submenu select 8. LOGIC PROCESSOR
3. From the LOGIC PROCESSOR Submenu select 1. LOGIC STATEMENT CONTROL

ENABLE LOGIC PROCESSOR STATEMENT 1 BY POSITIONING THE CURSOR OVER THE FIELD SHOWN BELOW AND USING THE TOGGLE KEY TO ENABLE IT.

LOGIC STATEMENT CONTROL																
	1	2	3	4	5	6	7	8	9	0	1	2	3	4	5	6
LP 1-15	E
LP 16-30
LP 31-45
LP 46-60
LP 61-75
LP 76-90

END PROGRAMMING

THIS ELECTRICAL DETAIL IS FOR THE SIGNAL DESIGN: 05-2008T3
DESIGN: June 2025
SEALED: 08/11/2025
REVISED: N/A

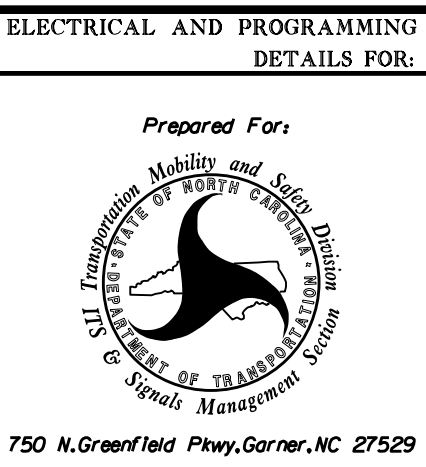
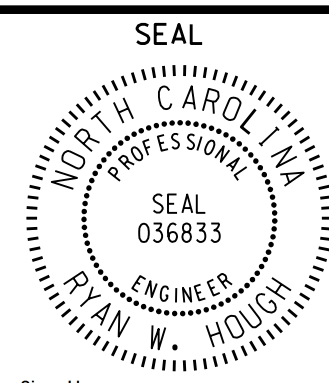
Electrical Detail - Sheet 3 of 5		DOCUMENT NOT CONSIDERED FINAL UNLESS ALL SIGNATURES COMPLETED		
	Prepared For: NC 54 (S. Miami Boulevard) at SR 1978 (Hopson Road)/ SR 1973 (Page Road)	SEAL		
	Division 5 Durham County Durham			
	PLAN DATE: July 2025 REVIEWED BY:	PREPARED BY: S. Kirkpatrick REVIEWED BY:		
	REVISIONS		INIT.	DATE
		Signed by: <u>Ryan W. Hough</u> 08/11/2025 DATE		
		SIG. INVENTORY NO. 05-2008T3		

I:\1-AUG-2025 11:37
D:\ncdot-pw-bentley.com\ncdot-pw-01\Documents\NCDOT_TSMO\SIGNAL Design\Signal\05-2008\51signals Management\052008T3-sm.le_20250811.dgn
sgk:rp@ncdot.gov

ASC/3 FLASH SENSE INPUT CONTROL FOR RED-RED FLASH

*The NCDOT default database is programmed to address Yellow-Red flash. Logic Statement 100 must be modified as shown when running Red-Red flash.

1. From Main Menu select 1. CONFIGURATION
2. From CONFIGURATION Submenu select 8. LOGIC PROCESSOR
3. From LOGIC PROCESSOR Submenu select 2. LOGIC STATEMENTS

Change the "LP" to 100 and move the cursor down. Delete the two "CTR-SET" statements by moving the cursor over them and hitting the "C" key. then hit "ENTER". select "LP SET CIB ON", hit "ENT", and then set the number to 427.

```

LP#:100 COPY FROM:100 ACTIVE: M FALSE
IF LP CIB CODE ON 331 F

THEN LP DELAY FOR 1.0 SECONDS
LP SET CIB ON 427

ELSE
  
```

THIS STATEMENT IS USED TO CONTROL THE FLASH SENSE INPUT WHEN RUNNING RED-RED FLASH OPERATION.

Hit "ESC", then 1 for "LOGIC STATEMENT CONTROL", next verify that LP#100 is ENABLED.

END PROGRAMMING

ECONOLITE ASC/3-2070 STARTUP AND SOFTWARE FLASH PROGRAMMING DETAIL

(program controller as shown)

1. From Main Menu select 2. CONTROLLER
2. From CONTROLLER Submenu select 5. START/FLASH

```

START/FLASH DATA
-----START UP-----
1 2 3 4 5 6 7 8 9 0 1 2 3 4 5 6
PHASE      G      G
           A B C D E F G H I J K L M N O P
OVERLAP X X X X X X X X X X X X X X X X
FLASH>MON. NO FL TIME.. 0 ALL RED... 6
PWR START SEQ.. 1 MUTCD> NO Y- G: NO
  
```

Scroll down on this screen and set "Exit FI" to Green "G"

NOTE: Do not use programmed (controller) flash when MUTCD is set to "NO".

FLASHER CIRCUIT MODIFICATION DETAIL

IN ORDER TO ENSURE THAT SIGNALS FLASH CONCURRENTLY ON THE SAME APPROACH, MAKE THE FOLLOWING FLASHER CIRCUIT CHANGES:



1. ON REAR OF PDA - REMOVE WIRE FROM TERM. T2-4 AND TERMINATE ON T2-2.
2. ON REAR OF PDA - REMOVE WIRE FROM TERM. T2-5 AND TERMINATE ON T2-3.
3. REMOVE FLASHER UNIT 2.

THE CHANGES LISTED ABOVE TIES ALL PHASES AND OVERLAPS TO FLASHER UNIT 1.

ACCESSIBLE PEDESTRIAN SIGNAL (APS) INSTALLATION NOTES

1. Install push buttons and APS equipment per manufacturer's instructions.
2. Provide a dedicated cable to each push button per manufacturer's instructions.
3. If APS equipment is mounted in cabinet, use filtered power (i.e., Controller Receptacle) to power APS equipment. Do not use Equipment Receptacle, which is a GFCI outlet.
4. Never attempt to operate a standard contact closure push button with the APS system unless cabinet is re-wired for standard button operation or unless explicitly allowed by the manufacturer.
5. Place manufacturer's instructions in cabinet with cabinet prints, signal plans, and electrical details.
6. An APS push button station that is designed to work without the need for interfacing with a pedestrian signal head shall be installed for applications where a push button is installed in a median without a pedestrian signal head.
7. A push button with a single tactile arrow that points in both directions of travel shall be installed if the median separates two parallel crosswalks.

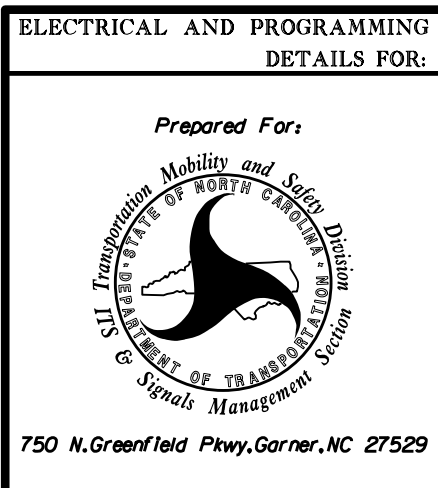
THIS ELECTRICAL DETAIL IS FOR THE SIGNAL DESIGN: 05-2008
DESIGN: April 2025
SEALED: 08/11/2025
REVISED: N/A

Electrical Detail - Sheet 4 of 5		DOCUMENT NOT CONSIDERED FINAL UNLESS ALL SIGNATURES COMPLETED
	<p>NC 54 (S. Miami Boulevard) at SR 1978 (Hopson Road) / SR 1973 (Page Road)</p> <p>Division 5 Durham County Durham</p> <p>Prepared For: S. Kirkpatrick</p> <p>PLAN DATE: July 2025 REVIEWED BY:</p> <p>REVISIONS: _____ INIT. DATE</p>	 <p>Signed by: Ryan W. Haugh 08/11/2025 DATE</p> <p>SIG. INVENTORY NO. 05-2008</p>

I:\AUG-2025_11\46 p:\ncdot-pw-bentley.com\ncdot-pw-bentley.com\05-2008\Signal Management\052008_sm_ele_20250811.dgn

ASC/3 FLASH SENSE INPUT CONTROL FOR RED-RED FLASH

*The NCDOT default database is programmed to address Yellow-Red flash.
Logic Statement 100 must be modified as shown when running Red-Red flash.

1. From Main Menu select 1. CONFIGURATION
2. From CONFIGURATION Submenu select 8. LOGIC PROCESSOR
3. From LOGIC PROCESSOR Submenu select 2. LOGIC STATEMENTS

Change the "LP" to 100 and move the cursor down. Delete the two "CTR-SET" statements by moving the cursor over them and hitting the "C" key. then hit "ENTER", select "LP SET CIB ON", hit "ENT", and then set the number to 427.

```

LP#:100 COPY FROM:100 ACTIVE: M FALSE
IF LP CIB CODE ON 331 F

THEN LP DELAY FOR 1.0 SECONDS
LP SET CIB ON 427

ELSE
```

THIS STATEMENT IS USED TO CONTROL THE FLASH SENSE INPUT WHEN RUNNING RED-RED FLASH OPERATION.

Hit "ESC", then 1 for "LOGIC STATEMENT CONTROL", next verify that LP#100 is ENABLED.

END PROGRAMMING

ECONOLITE ASC/3-2070 STARTUP AND SOFTWARE FLASH PROGRAMMING DETAIL

(program controller as shown)

1. From Main Menu select 2. CONTROLLER
2. From CONTROLLER Submenu select 5. START/FLASH

```

START/FLASH DATA
-----START UP-----
          1 2 3 4 5 6 7 8 9 0 1 2 3 4 5 6
PHASE      G      G
          A B C D E F G H I J K L M N O P
OVERLAP X X X X X X X X X X X X X X X X
FLASH>MON. NO FL TIME.. 0 ALL RED... 6
PWR START SEQ.. 1 MUTCD> NO Y- G: NO
```

Scroll down on this screen and set "Exit FI" to Green "G"

NOTE: Do not use programmed (controller) flash when MUTCD is set to "NO".

FLASHER CIRCUIT MODIFICATION DETAIL

IN ORDER TO ENSURE THAT SIGNALS FLASH CONCURRENTLY ON THE SAME APPROACH, MAKE THE FOLLOWING FLASHER CIRCUIT CHANGES:

1. ON REAR OF PDA - REMOVE WIRE FROM TERM. T2-4 AND TERMINATE ON T2-2.
2. ON REAR OF PDA - REMOVE WIRE FROM TERM. T2-5 AND TERMINATE ON T2-3.
3. REMOVE FLASHER UNIT 2.

THE CHANGES LISTED ABOVE TIES ALL PHASES AND OVERLAPS TO FLASHER UNIT 1.

THIS ELECTRICAL DETAIL IS FOR THE SIGNAL DESIGN: 05-2008T1
DESIGN: June 2025
SEALED: 08/11/2025
REVISED: N/A

I:\AUG-2025 11:23
 p:\ncdot-pw\benr\ey.com\ncdot-pw-01\Documents\NCDOT TSMO\Signal Design\Signal Management\052008T1.sm.le.20250811.dgn
 sgm.r.r.pattick

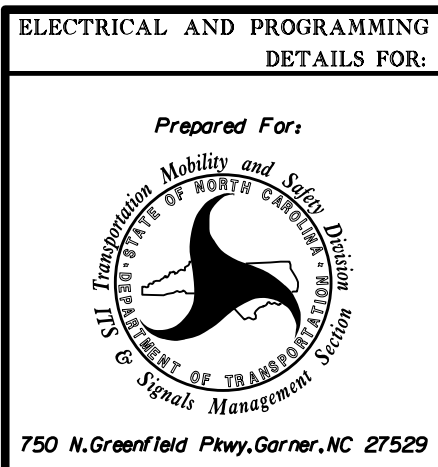
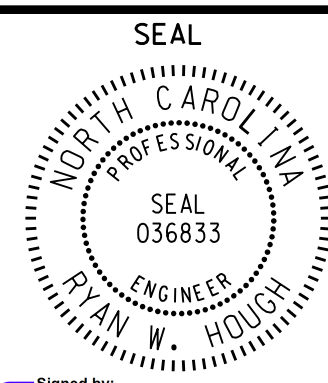
Electrical Detail - Sheet 4 of 5		DOCUMENT NOT CONSIDERED FINAL UNLESS ALL SIGNATURES COMPLETED												
ELECTRICAL AND PROGRAMMING DETAILS FOR: 	NC 54 (S. Miami Boulevard) at SR 1978 (Hopson Road) / SR 1973 (Page Road) Division 5 Durham County Durham PLAN DATE: July 2025 REVIEWED BY: PREPARED BY: S. Kirkpatrick REVIEWED BY: <table border="1" style="width: 100%; border-collapse: collapse; font-size: x-small;"> <thead> <tr> <th>REVISIONS</th> <th>INIT.</th> <th>DATE</th> </tr> </thead> <tbody> <tr><td> </td><td> </td><td> </td></tr> <tr><td> </td><td> </td><td> </td></tr> <tr><td> </td><td> </td><td> </td></tr> </tbody> </table>	REVISIONS	INIT.	DATE										SEAL  SEAL 036833 ENGINEER RYAN W. HOUGH Signed by: <u>Ryan W. Hough</u> 08/11/2025 DATE 43030FA6085473 SIG. INVENTORY NO. 05-2008T1
REVISIONS	INIT.	DATE												

ASC/3 FLASH SENSE INPUT CONTROL FOR RED-RED FLASH

*The NCDOT default database is programmed to address Yellow-Red flash.
Logic Statement 100 must be modified as shown when running Red-Red flash.

1. From Main Menu select 1. CONFIGURATION
2. From CONFIGURATION Submenu select 8. LOGIC PROCESSOR
3. From LOGIC PROCESSOR Submenu select 2. LOGIC STATEMENTS

Change the "LP" to 100 and move the cursor down. Delete the two "CTR-SET" statements by moving the cursor over them and hitting the "C" key. then hit "ENTER", select "LP SET CIB ON", hit "ENT", and then set the number to 427.

```

LP#:100 COPY FROM:100 ACTIVE: M FALSE
IF LP CIB CODE ON 331 F

THEN LP DELAY FOR 1.0 SECONDS
LP SET CIB ON 427

ELSE
  
```

THIS STATEMENT IS USED TO CONTROL THE FLASH SENSE INPUT WHEN RUNNING RED-RED FLASH OPERATION.

Hit "ESC", then 1 for "LOGIC STATEMENT CONTROL", next verify that LP#100 is ENABLED.

END PROGRAMMING

ECONOLITE ASC/3-2070 STARTUP AND SOFTWARE FLASH PROGRAMMING DETAIL

(program controller as shown)

1. From Main Menu select 2. CONTROLLER
2. From CONTROLLER Submenu select 5. START/FLASH

```

START/FLASH DATA
-----START UP-----
          1 2 3 4 5 6 7 8 9 0 1 2 3 4 5 6
PHASE      G      G
          A B C D E F G H I J K L M N O P
OVERLAP X X X X X X X X X X X X X X X X
FLASH>MON. NO FL TIME.. 0 ALL RED... 6
PWR START SEQ.. 1 MUTCD> NO Y- G: NO
  
```

Scroll down on this screen and set "Exit FI" to Green "G"

NOTE: Do not use programmed (controller) flash when MUTCD is set to "NO".

FLASHER CIRCUIT MODIFICATION DETAIL

IN ORDER TO ENSURE THAT SIGNALS FLASH CONCURRENTLY ON THE SAME APPROACH, MAKE THE FOLLOWING FLASHER CIRCUIT CHANGES:

1. ON REAR OF PDA - REMOVE WIRE FROM TERM. T2-4 AND TERMINATE ON T2-2.
2. ON REAR OF PDA - REMOVE WIRE FROM TERM. T2-5 AND TERMINATE ON T2-3.
3. REMOVE FLASHER UNIT 2.

THE CHANGES LISTED ABOVE TIES ALL PHASES AND OVERLAPS TO FLASHER UNIT 1.

THIS ELECTRICAL DETAIL IS FOR THE SIGNAL DESIGN: 05-2008T2
DESIGN: June 2025
SEALED: 08/11/2025
REVISED: N/A

I:\AUG-2025\11130\pwr\ncdot-pw-bentley.com\ncdot-pw-01\Documents\NCDOT_TSMO\Signal Design\Signal Design\05-2008T2.sm.eie-20250811.dgn
 25/08/2025 11:30
 pwr\ncdot-pw-bentley.com\ncdot-pw-01\Documents\NCDOT_TSMO\Signal Design\Signal Design\05-2008T2.sm.eie-20250811.dgn
 25/08/2025 11:30

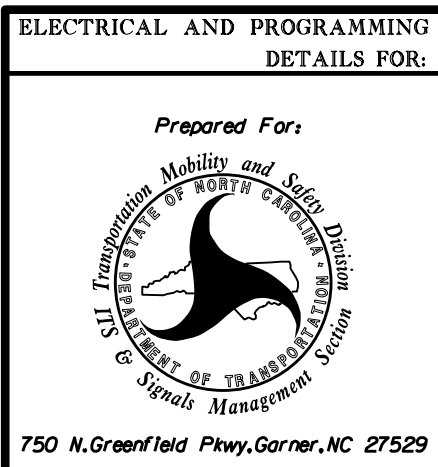
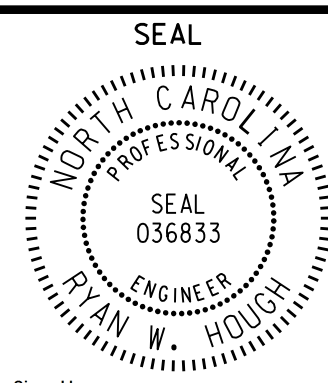
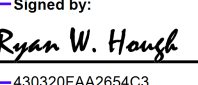
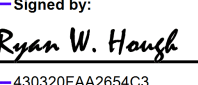
Electrical Detail - Sheet 4 of 5		DOCUMENT NOT CONSIDERED FINAL UNLESS ALL SIGNATURES COMPLETED						
ELECTRICAL AND PROGRAMMING DETAILS FOR: 	NC 54 (S. Miami Boulevard) at SR 1978 (Hopson Road)/ SR 1973 (Page Road) Division 5 Durham County Durham PLAN DATE: July 2025 REVIEWED BY: PREPARED BY: S. Kirkpatrick REVIEWED BY: <table border="1" style="width: 100%; border-collapse: collapse; font-size: x-small;"> <tr> <th>REVISIONS</th> <th>INIT.</th> <th>DATE</th> </tr> <tr> <td> </td> <td> </td> <td> </td> </tr> </table>	REVISIONS	INIT.	DATE				SEAL  SEAL 036833 RYAN W. HOUGH ENGINEER
REVISIONS	INIT.	DATE						
Prepared For:  08/11/2025 DATE		SIGNED BY:  08/11/2025 DATE SIG. INVENTORY NO. 05-2008T2						

ASC/3 FLASH SENSE INPUT CONTROL FOR RED-RED FLASH

*The NCDOT default database is programmed to address Yellow-Red flash.
Logic Statement 100 must be modified as shown when running Red-Red flash.

1. From Main Menu select 1. CONFIGURATION
2. From CONFIGURATION Submenu select 8. LOGIC PROCESSOR
3. From LOGIC PROCESSOR Submenu select 2. LOGIC STATEMENTS

Change the "LP" to 100 and move the cursor down. Delete the two "CTR-SET" statements by moving the cursor over them and hitting the "C" key. then hit "ENTER", select "LP SET CIB ON", hit "ENT", and then set the number to 427.

```

LP#:100 COPY FROM:100 ACTIVE: M FALSE
IF LP CIB CODE ON 331 F

THEN LP DELAY FOR 1.0 SECONDS
LP SET CIB ON 427

ELSE
  
```

THIS STATEMENT IS USED TO CONTROL THE FLASH SENSE INPUT WHEN RUNNING RED-RED FLASH OPERATION.

Hit "ESC", then 1 for "LOGIC STATEMENT CONTROL", next verify that LP#100 is ENABLED.

END PROGRAMMING

ECONOLITE ASC/3-2070 STARTUP AND SOFTWARE FLASH PROGRAMMING DETAIL

(program controller as shown)

1. From Main Menu select 2. CONTROLLER
2. From CONTROLLER Submenu select 5. START/FLASH

```

START/FLASH DATA
-----START UP-----
          1 2 3 4 5 6 7 8 9 0 1 2 3 4 5 6
PHASE      G      G
          A B C D E F G H I J K L M N O P
OVERLAP X X X X X X X X X X X X X X X X
FLASH>MON. NO FL TIME.. 0 ALL RED... 6
PWR START SEQ.. 1 MUTCD> NO Y- G: NO
  
```

Scroll down on this screen and set "Exit FI" to Green "G"

NOTE: Do not use programmed (controller) flash when MUTCD is set to "NO".

FLASHER CIRCUIT MODIFICATION DETAIL

IN ORDER TO ENSURE THAT SIGNALS FLASH CONCURRENTLY ON THE SAME APPROACH, MAKE THE FOLLOWING FLASHER CIRCUIT CHANGES:

1. ON REAR OF PDA - REMOVE WIRE FROM TERM. T2-4 AND TERMINATE ON T2-2.
2. ON REAR OF PDA - REMOVE WIRE FROM TERM. T2-5 AND TERMINATE ON T2-3.
3. REMOVE FLASHER UNIT 2.

THE CHANGES LISTED ABOVE TIES ALL PHASES AND OVERLAPS TO FLASHER UNIT 1.

THIS ELECTRICAL DETAIL IS FOR THE SIGNAL DESIGN: 05-2008T3
DESIGN: June 2025
SEALED: 08/11/2025
REVISED: N/A

I:\AUG-2025\11138\pdx\ncdot-pw-bentley.com\ncdot-pw-01\Documents\NCDOT_TSMO\Signal Design\Signal Management\052008T3.sm.le.20250811.dgn
 2961.r.pattick

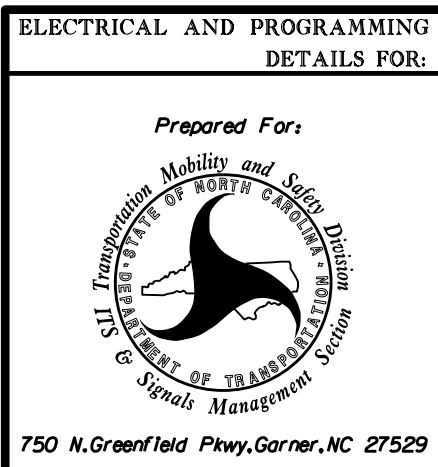
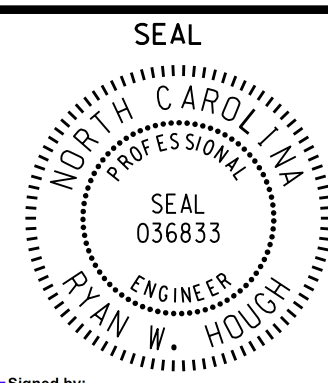
Electrical Detail - Sheet 4 of 5		DOCUMENT NOT CONSIDERED FINAL UNLESS ALL SIGNATURES COMPLETED												
ELECTRICAL AND PROGRAMMING DETAILS FOR: 	NC 54 (S. Miami Boulevard) at SR 1978 (Hopson Road) / SR 1973 (Page Road) Division 5 Durham County Durham PLAN DATE: July 2025 REVIEWED BY: PREPARED BY: S. Kirkpatrick REVIEWED BY: <table border="1" style="width: 100%; font-size: x-small;"> <thead> <tr> <th>REVISIONS</th> <th>INIT.</th> <th>DATE</th> </tr> </thead> <tbody> <tr><td> </td><td> </td><td> </td></tr> <tr><td> </td><td> </td><td> </td></tr> <tr><td> </td><td> </td><td> </td></tr> </tbody> </table>	REVISIONS	INIT.	DATE										SEAL  SEAL 036833 ENGINEER RYAN W. HOUGH
REVISIONS	INIT.	DATE												
Signed by: <u>Ryan W. Hough</u> 08/11/2025 <small>130320FA2085G3 DATE</small>		SIG. INVENTORY NO. 05-2008T3												

ECONOLITE ASC/3-2070 ACTION PLAN PROGRAMMING DETAIL

1. From Main Menu select 5. TIME BASE
2. From TIME BASE Submenu select 2. ACTION PLAN

ACTION PLAN... [1]										
PATTERN.....	AUTO	SYS OVERRIDE....	NO							
TIMING PLAN.....	0	SEQUENCE.....	0							
VEH DETECTOR PLAN..	2	DET LOG.....	NONE							
FLASH.....	--	RED REST.....	NO							
VEH DET DIAG PLN...	0	PED DET DIAG PLN..	0							
DIMMING ENABLE..	NO	PRIORITY RETURN.	NO							
PED PR RETURN..	NO	QUEUE DELAY.....	NO							
PMT COND DELAY	NO									
PHASE	1	2	3	4	5	6	7	8	9	0
PED RCL
WALK 2
VEX 2
VEH RCL
MAX RCL
MAX 2
PHASE	1	2	3	4	5	6	7	8	9	0
MAX 3
CS INH
OMIT
SPC FCT	X	.	X	.	X	.	X	.	(1-8)	
AUX FCT	.	.	.	(1-3)						
	1	2	3	4	5	6	7	8	9	0
LP 1-15
LP 16-30
LP 31-45
LP 46-60
LP 61-75
LP 76-90
LP 91-100

NOTE: Action Plan [1] is shown as a reference only. The actual Action Plan number(s) will be determined by the Town Traffic Engineer.

ALTERNATE PHASING ACTIVATION DETAIL

TO RUN ALT. PHASING DURING FREE RUN - PROGRAM CHANGES (SHOWN BELOW) IN A TIME BASED ACTION PLAN. SCHEDULE A DAY PLAN THAT INCLUDES THE ACTION PLAN PROGRAMMED TO SELECT VEH DET PLAN 2 AND ENABLE SF BITS 1, 3, 5, and 7.

TO RUN ALT. PHASING DURING COORDINATION - SELECT THE TIME BASED ACTION PLAN THAT IS PROGRAMMED TO SELECT VEH DET PLAN 2 AND ENABLE SF BITS 1, 3, 5, and 7.

PHASING	VEH DET PLAN	SF BITS ENABLED
ACTIONS REQUIRED TO RUN <u>DEFAULT PHASING</u>	1	NONE
ACTIONS REQUIRED TO RUN <u>ALTERNATE PHASING</u>	2	1, 3, 5, 7

IMPORTANT: IF ALT. PHASING IS USED DURING FREE RUN AND COORDINATION, DO NOT OPERATE TIME OF DAY EVENTS CONCURRENTLY WITH COORDINATION PLAN EVENTS IN THE EVENT SCHEDULER. (EX. FREE RUN EVENT SHOULD END BEFORE COORDINATION PLAN EVENT STARTS AND VICE-VERSA).

ALTERNATE PHASING CHANGE SUMMARY

THE FOLLOWING IS A SUMMARY OF WHAT TAKES PLACE WHEN SF BITS 1, 3, 5, AND 7 AND VEH DET PLAN 2 ACTIVATE TO CALL THE "ALTERNATE PHASING":

SF BITS 1,3,5,7: Modifies overlap parent phases for heads 11, 31, 51, and 71 to run protected turns only.

VEH DET PLAN 2:

- Disables phase 6 call on loop 1A and reduces delay time for phase 1 call on loop 1A to 3 seconds.
- Disables phase 8 call on loop 3A and reduces delay time for phase 3 call on loop 3A to 0 seconds.
- Disables phase 2 call on loop 5A and reduces delay time for phase 5 call on loop 5A to 3 seconds.
- Disables phase 4 call on loop 7A and reduces delay time for phase 7 call on loop 7A to 0 seconds.

THIS ELECTRICAL DETAIL IS FOR THE SIGNAL DESIGN: 05-2008
 DESIGN: April 2025
 SEALED: 08/11/2025
 REVISED: N/A

Electrical Detail - Sheet 5 of 5

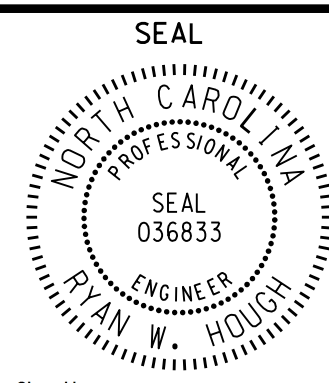
 <p>750 N. Greenfield Pkwy, Garner, NC 27529</p>	<p>NC 54 (S. Miami Boulevard) at SR 1978 (Hopson Road) / SR 1973 (Page Road)</p> <p>Division 5 Durham County Durham</p> <p>PLAN DATE: July 2025 REVIEWED BY:</p> <p>PREPARED BY: S. Kirkpatrick REVIEWED BY:</p>	<p>DOCUMENT NOT CONSIDERED FINAL UNLESS ALL SIGNATURES COMPLETED</p> <p>SEAL</p>  <p>Signed by: <u>Ryan W. Hough</u> 08/11/2025</p> <p>DATE</p> <p>SIG. INVENTORY NO. 05-2008</p>						
<table border="1" style="width: 100%; border-collapse: collapse;"> <thead> <tr> <th>REVISIONS</th> <th>INIT.</th> <th>DATE</th> </tr> </thead> <tbody> <tr> <td> </td> <td> </td> <td> </td> </tr> </tbody> </table>			REVISIONS	INIT.	DATE			
REVISIONS	INIT.	DATE						

I:\AUG-2025_11\46... Design Section\01\Documents\NC DOT TSMO\Signal Design\Signal Design\05-2008\Signal Management\052008_sm.ele_20250811.dgn

ECONOLITE ASC/3-2070 ACTION PLAN PROGRAMMING DETAIL

- 1. From Main Menu select **5. TIME BASE**
- 2. From TIME BASE Submenu select **2. ACTION PLAN**

ACTION PLAN... [1]																	
PATTERN.....	AUTO	SYS OVERRIDE....	NO														
TIMING PLAN.....	0	SEQUENCE.....	0														
VEH DETECTOR PLAN..	2	DET LOG.....	NONE														
FLASH.....	--	RED REST.....	NO														
VEH DET DIAG PLN...	0	PED DET DIAG PLN..	0														
DIMMING ENABLE..	NO	PRIORITY RETURN.	NO														
PED PR RETURN..	NO	QUEUE DELAY.....	NO														
PMT COND DELAY	NO																
PHASE	1	2	3	4	5	6	7	8	9	0	1	2	3	4	5	6	
PED RCL
WALK 2
VEX 2
VEH RCL
MAX RCL
MAX 2
PHASE	1	2	3	4	5	6	7	8	9	0	1	2	3	4	5	6	
MAX 3
CS INH
OMIT
SPC FCT	X	.	X	.	X	.	X	.	X	.	(1-8)						
AUX FCT	(1-3)												
	1	2	3	4	5	6	7	8	9	0	1	2	3	4	5		
LP 1-15
LP 16-30
LP 31-45
LP 46-60
LP 61-75
LP 76-90
LP 91-100

NOTE: Action Plan [1] is shown as a reference only. The actual Action Plan number(s) will be determined by the Town Traffic Engineer.

ALTERNATE PHASING ACTIVATION DETAIL

TO RUN ALT. PHASING DURING FREE RUN - PROGRAM CHANGES (SHOWN BELOW) IN A TIME BASED ACTION PLAN. SCHEDULE A DAY PLAN THAT INCLUDES THE ACTION PLAN PROGRAMMED TO SELECT VEH DET PLAN 2 AND ENABLE SF BITS 1, 3, 5, and 7.

TO RUN ALT. PHASING DURING COORDINATION - SELECT THE TIME BASED ACTION PLAN THAT IS PROGRAMMED TO SELECT VEH DET PLAN 2 AND ENABLE SF BITS 1, 3, 5, and 7.

PHASING	VEH DET PLAN	SF BITS ENABLED
ACTIONS REQUIRED TO RUN <u>DEFAULT PHASING</u>	1	NONE
ACTIONS REQUIRED TO RUN <u>ALTERNATE PHASING</u>	2	1, 3, 5, 7

IMPORTANT: IF ALT. PHASING IS USED DURING FREE RUN AND COORDINATION, DO NOT OPERATE TIME OF DAY EVENTS CONCURRENTLY WITH COORDINATION PLAN EVENTS IN THE EVENT SCHEDULER. (EX. FREE RUN EVENT SHOULD END BEFORE COORDINATION PLAN EVENT STARTS AND VICE-VERSA).

ALTERNATE PHASING CHANGE SUMMARY

THE FOLLOWING IS A SUMMARY OF WHAT TAKES PLACE WHEN SF BITS 1, 3, 5, AND 7 AND VEH DET PLAN 2 ACTIVATE TO CALL THE "ALTERNATE PHASING":

SF BITS 1,3,5,7: Modifies overlap parent phases for heads 11, 31, 51, and 71 to run protected turns only.

VEH DET PLAN 2:

- Disables phase 6 call on loop 1A and reduces delay time for phase 1 call on loop 1A to 3 seconds.
- Disables phase 8 call on loop 3A and reduces delay time for phase 3 call on loop 3A to 0 seconds.
- Disables phase 2 call on loop 5A and reduces delay time for phase 5 call on loop 5A to 3 seconds.
- Disables phase 4 call on loop 7A and reduces delay time for phase 7 call on loop 7A to 0 seconds.

THIS ELECTRICAL DETAIL IS FOR THE SIGNAL DESIGN: 05-2008T1
 DESIGN: June 2025
 SEALED: 08/11/2025
 REVISED: N/A

I:\AUG-2025_11:53 p.m.\\ncdot-pw-bentley.com\ncdot-pw-01\Documents\NCDOT_TSMO\SIGNAL_Design_Sect1ar\01\vision_05\05-2008\Signal_Management\052008T1.sm.le_20250811.dgn

Electrical Detail - Sheet 5 of 5

	Prepared For: NC 54 (S. Miami Boulevard) at SR 1978 (Hopson Road) / SR 1973 (Page Road)	DOCUMENT NOT CONSIDERED FINAL UNLESS ALL SIGNATURES COMPLETED
	Division 5 Durham County Durham	SEAL NORTH CAROLINA PROFESSIONAL ENGINEER SEAL 036833 RYAN W. HOFF
	PLAN DATE: July 2025 PREPARED BY: S.Kirkpatrick	REVIEWED BY: REVIEWED BY:
	REVISIONS INIT. DATE	SIGNED BY: <u>Ryan W. Hoff</u> 08/11/2025 DATE

SIG. INVENTORY NO. 05-2008T1

ECONOLITE ASC/3-2070 ACTION PLAN PROGRAMMING DETAIL

ALTERNATE PHASING ACTIVATION DETAIL

TO RUN ALT. PHASING DURING FREE RUN - PROGRAM CHANGES (SHOWN BELOW) IN A TIME BASED ACTION PLAN. SCHEDULE A DAY PLAN THAT INCLUDES THE ACTION PLAN PROGRAMMED TO SELECT VEH DET PLAN 2 AND ENABLE SF BITS 1, 3, 5, and 7.

TO RUN ALT. PHASING DURING COORDINATION - SELECT THE TIME BASED ACTION PLAN THAT IS PROGRAMMED TO SELECT VEH DET PLAN 2 AND ENABLE SF BITS 1, 3, 5, and 7.

PHASING	VEH DET PLAN	SF BITS ENABLED
ACTIONS REQUIRED TO RUN <u>DEFAULT PHASING</u>	1	NONE
ACTIONS REQUIRED TO RUN <u>ALTERNATE PHASING</u>	2	1, 3, 5, 7

IMPORTANT: IF ALT. PHASING IS USED DURING FREE RUN AND COORDINATION, DO NOT OPERATE TIME OF DAY EVENTS CONCURRENTLY WITH COORDINATION PLAN EVENTS IN THE EVENT SCHEDULER. (EX. FREE RUN EVENT SHOULD END BEFORE COORDINATION PLAN EVENT STARTS AND VICE-VERSA).

ALTERNATE PHASING CHANGE SUMMARY

THE FOLLOWING IS A SUMMARY OF WHAT TAKES PLACE WHEN SF BITS 1, 3, 5, AND 7 AND VEH DET PLAN 2 ACTIVATE TO CALL THE "ALTERNATE PHASING":

SF BITS 1,3,5,7: Modifies overlap parent phases for heads 11, 31, 51, and 71 to run protected turns only.

VEH DET PLAN 2:

- Disables phase 6 call on loop 1A and reduces delay time for phase 1 call on loop 1A to 3 seconds.
- Disables phase 8 call on loop 3A and reduces delay time for phase 3 call on loop 3A to 0 seconds.
- Disables phase 2 call on loop 5A and reduces delay time for phase 5 call on loop 5A to 3 seconds.
- Disables phase 4 call on loop 7A and reduces delay time for phase 7 call on loop 7A to 0 seconds.

- From Main Menu select **5. TIME BASE**
- From TIME BASE Submenu select **2. ACTION PLAN**

```

ACTION PLAN... [ 1 ]
PATTERN.....AUTO   SYS OVERRIDE.... NO
TIMING PLAN..... 0   SEQUENCE..... 0
VEH DETECTOR PLAN.. 2   DET LOG.....NONE
FLASH..... --      RED REST..... NO
VEH DET DIAG PLN... 0   PED DET DIAG PLN..0
DIMMING ENABLE.. NO   PRIORITY RETURN. NO
PED PR RETURN.. NO   QUEUE DELAY..... NO
PMT COND DELAY NO

  PHASE  1  2  3  4  5  6  7  8  9  0  1  2  3  4  5  6
PED RCL  .  .  .  .  .  .  .  .  .  .  .  .  .  .  .  .
WALK 2   .  .  .  .  .  .  .  .  .  .  .  .  .  .  .  .
VEX 2    .  .  .  .  .  .  .  .  .  .  .  .  .  .  .  .
VEH RCL  .  .  .  .  .  .  .  .  .  .  .  .  .  .  .  .
MAX RCL  .  .  .  .  .  .  .  .  .  .  .  .  .  .  .  .
MAX 2    .  .  .  .  .  .  .  .  .  .  .  .  .  .  .  .
  PHASE  1  2  3  4  5  6  7  8  9  0  1  2  3  4  5  6
MAX 3    .  .  .  .  .  .  .  .  .  .  .  .  .  .  .  .
CS INH   .  .  .  .  .  .  .  .  .  .  .  .  .  .  .  .
OMIT     .  .  .  .  .  .  .  .  .  .  .  .  .  .  .  .
SPC FCT  X  .  X  .  X  .  X  .  (1-8)
AUX FCT  .  .  .  (1-3)

  PHASE  1  2  3  4  5  6  7  8  9  0  1  2  3  4  5
LP 1-15  .  .  .  .  .  .  .  .  .  .  .  .  .  .  .  .
LP 16-30 .  .  .  .  .  .  .  .  .  .  .  .  .  .  .  .
LP 31-45 .  .  .  .  .  .  .  .  .  .  .  .  .  .  .  .
LP 46-60 .  .  .  .  .  .  .  .  .  .  .  .  .  .  .  .
LP 61-75 .  .  .  .  .  .  .  .  .  .  .  .  .  .  .  .
LP 76-90 .  .  .  .  .  .  .  .  .  .  .  .  .  .  .  .
LP 91-100 .  .  .  .  .  .  .  .  .  .  .  .  .  .  .  .
    
```

NOTE: Action Plan [1] is shown as a reference only. The actual Action Plan number(s) will be determined by the Town Traffic Engineer.

THIS ELECTRICAL DETAIL IS FOR THE SIGNAL DESIGN: 05-2008T2
 DESIGN: June 2025
 SEALED: 08/11/2025
 REVISED: N/A

Electrical Detail - Sheet 5 of 5

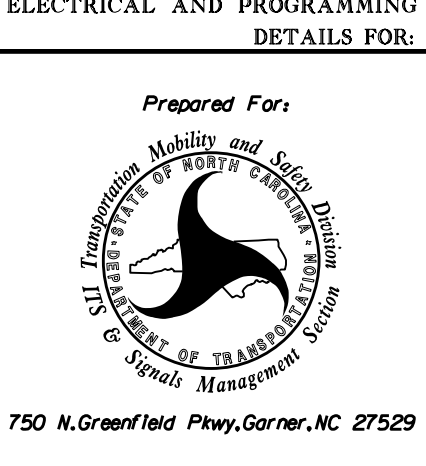
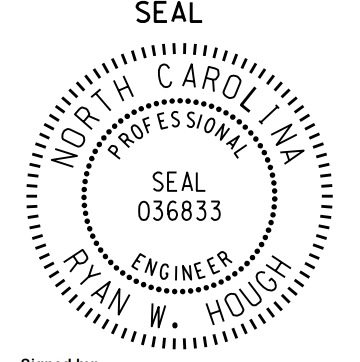
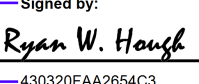
	Prepared For: NC 54 (S. Miami Boulevard) at SR 1978 (Hopson Road)/ SR 1973 (Page Road)		DOCUMENT NOT CONSIDERED FINAL UNLESS ALL SIGNATURES COMPLETED SEAL  SEAL 036833 RYAN W. HOUGH ENGINEER
	Division 5 Durham County Durham		
	PLAN DATE: July 2025	REVIEWED BY:	
	PREPARED BY: S.Kirkpatrick	REVIEWED BY:	
REVISIONS		INIT. DATE	Signed by:  08/11/2025 DATE
Electrical and Programming Details For:			SIG. INVENTORY NO. 05-2008T2

I:\AUG-2025_11:31
 p:\ncdot-pw-bentley.com\ncdot-pw-01\Documents\NCDOT_TSMO\SIGNAL Design_Sect1\ar01\vision_05\05-2008\Signal Management\052008T2.sm.le.20250811.dgn
 sgc:rkp:ck

ECONOLITE ASC/3-2070 ACTION PLAN PROGRAMMING DETAIL

ALTERNATE PHASING ACTIVATION DETAIL

TO RUN ALT. PHASING DURING FREE RUN - PROGRAM CHANGES (SHOWN BELOW) IN A TIME BASED ACTION PLAN. SCHEDULE A DAY PLAN THAT INCLUDES THE ACTION PLAN PROGRAMMED TO SELECT VEH DET PLAN 2 AND ENABLE SF BITS 1, 3, 5, and 7.

TO RUN ALT. PHASING DURING COORDINATION - SELECT THE TIME BASED ACTION PLAN THAT IS PROGRAMMED TO SELECT VEH DET PLAN 2 AND ENABLE SF BITS 1, 3, 5, and 7.

PHASING	VEH DET PLAN	SF BITS ENABLED
ACTIONS REQUIRED TO RUN <u>DEFAULT PHASING</u>	1	NONE
ACTIONS REQUIRED TO RUN <u>ALTERNATE PHASING</u>	2	1, 3, 5, 7

IMPORTANT: IF ALT. PHASING IS USED DURING FREE RUN AND COORDINATION, DO NOT OPERATE TIME OF DAY EVENTS CONCURRENTLY WITH COORDINATION PLAN EVENTS IN THE EVENT SCHEDULER. (EX. FREE RUN EVENT SHOULD END BEFORE COORDINATION PLAN EVENT STARTS AND VICE-VERSA).

ALTERNATE PHASING CHANGE SUMMARY

THE FOLLOWING IS A SUMMARY OF WHAT TAKES PLACE WHEN SF BITS 1, 3, 5, AND 7 AND VEH DET PLAN 2 ACTIVATE TO CALL THE "ALTERNATE PHASING":

SF BITS 1,3,5,7: Modifies overlap parent phases for heads 11, 31, 51, and 71 to run protected turns only.

VEH DET PLAN 2:

- Disables phase 6 call on loop 1A and reduces delay time for phase 1 call on loop 1A to 3 seconds.
- Disables phase 8 call on loop 3A and reduces delay time for phase 3 call on loop 3A to 0 seconds.
- Disables phase 2 call on loop 5A and reduces delay time for phase 5 call on loop 5A to 3 seconds.
- Disables phase 4 call on loop 7A and reduces delay time for phase 7 call on loop 7A to 0 seconds.

- From Main Menu select **5. TIME BASE**
- From TIME BASE Submenu select **2. ACTION PLAN**

```

ACTION PLAN... [ 1 ]
PATTERN.....AUTO   SYS OVERRIDE.... NO
TIMING PLAN..... 0   SEQUENCE..... 0
VEH DETECTOR PLAN.. 2   DET LOG.....NONE
FLASH..... --   RED REST..... NO
VEH DET DIAG PLN... 0   PED DET DIAG PLN..0
DIMMING ENABLE.. NO   PRIORITY RETURN. NO
PED PR RETURN.. NO   QUEUE DELAY..... NO
PMT COND DELAY NO

  PHASE  1  2  3  4  5  6  7  8  9  0  1  2  3  4  5  6
PED RCL  .  .  .  .  .  .  .  .  .  .  .  .  .  .  .  .
WALK 2   .  .  .  .  .  .  .  .  .  .  .  .  .  .  .  .
VEX 2    .  .  .  .  .  .  .  .  .  .  .  .  .  .  .  .
VEH RCL  .  .  .  .  .  .  .  .  .  .  .  .  .  .  .  .
MAX RCL  .  .  .  .  .  .  .  .  .  .  .  .  .  .  .  .
MAX 2    .  .  .  .  .  .  .  .  .  .  .  .  .  .  .  .
  PHASE  1  2  3  4  5  6  7  8  9  0  1  2  3  4  5  6
MAX 3    .  .  .  .  .  .  .  .  .  .  .  .  .  .  .  .
CS INH   .  .  .  .  .  .  .  .  .  .  .  .  .  .  .  .
OMIT     .  .  .  .  .  .  .  .  .  .  .  .  .  .  .  .
SPC FCT  X  .  X  .  X  .  X  .  (1-8)
AUX FCT  .  .  .  (1-3)
          1  2  3  4  5  6  7  8  9  0  1  2  3  4  5
LP 1-15  .  .  .  .  .  .  .  .  .  .  .  .  .  .  .  .
LP 16-30 .  .  .  .  .  .  .  .  .  .  .  .  .  .  .  .
LP 31-45 .  .  .  .  .  .  .  .  .  .  .  .  .  .  .  .
LP 46-60 .  .  .  .  .  .  .  .  .  .  .  .  .  .  .  .
LP 61-75 .  .  .  .  .  .  .  .  .  .  .  .  .  .  .  .
LP 76-90 .  .  .  .  .  .  .  .  .  .  .  .  .  .  .  .
LP 91-100 .  .  .  .  .  .  .  .  .  .  .  .  .  .  .  .
    
```

NOTE: Action Plan [1] is shown as a reference only. The actual Action Plan number(s) will be determined by the Town Traffic Engineer.

THIS ELECTRICAL DETAIL IS FOR THE SIGNAL DESIGN: 05-2008T3
 DESIGN: June 2025
 SEALED: 08/11/2025
 REVISED: N/A

Electrical Detail - Sheet 5 of 5

DOCUMENT NOT CONSIDERED FINAL UNLESS ALL SIGNATURES COMPLETED

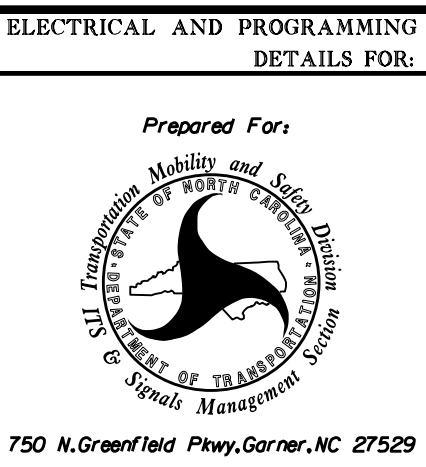
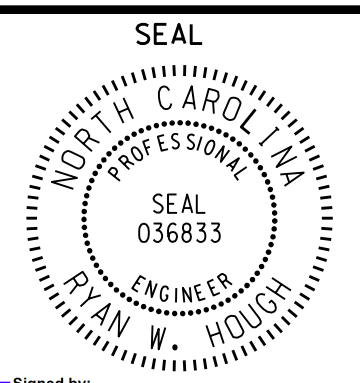
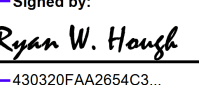
	Prepared For: NC 54 (S. Miami Boulevard) at SR 1978 (Hopson Road)/ SR 1973 (Page Road)		
	Division 5 Durham County Durham		
PLAN DATE: July 2025	REVIEWED BY:		Signed by:  08/11/2025
PREPARED BY: S.Kirkpatrick	REVIEWED BY:		
REVISIONS	INIT.	DATE	DATE

750 N. Greenfield Pkwy, Garner, NC 27529

SIG. INVENTORY NO. 05-2008T3

I:\AUG-2025_11:38
 p:\ncdot-pw-bentley.com\ncdot-pw-01\Documents\NCDOT_TSMO\SIGNAL Design_Sect1\ar01\vision_05\05-2008\Signal Management\052008T3.sm.le.20250811.dgn
 sgl:lr:report:ck

DEFAULT PHASING DIAGRAM

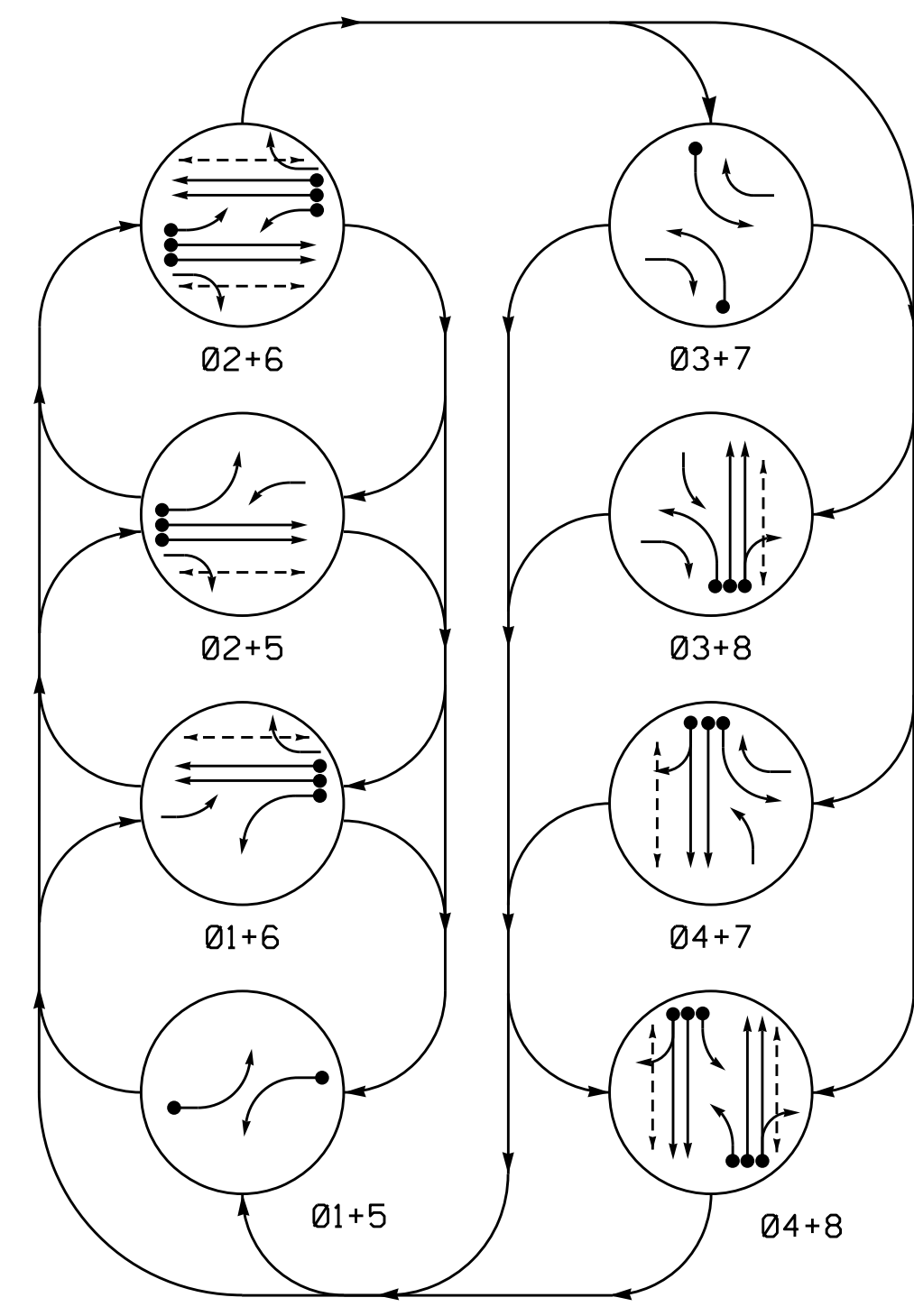

ALTERNATE PHASING DIAGRAM

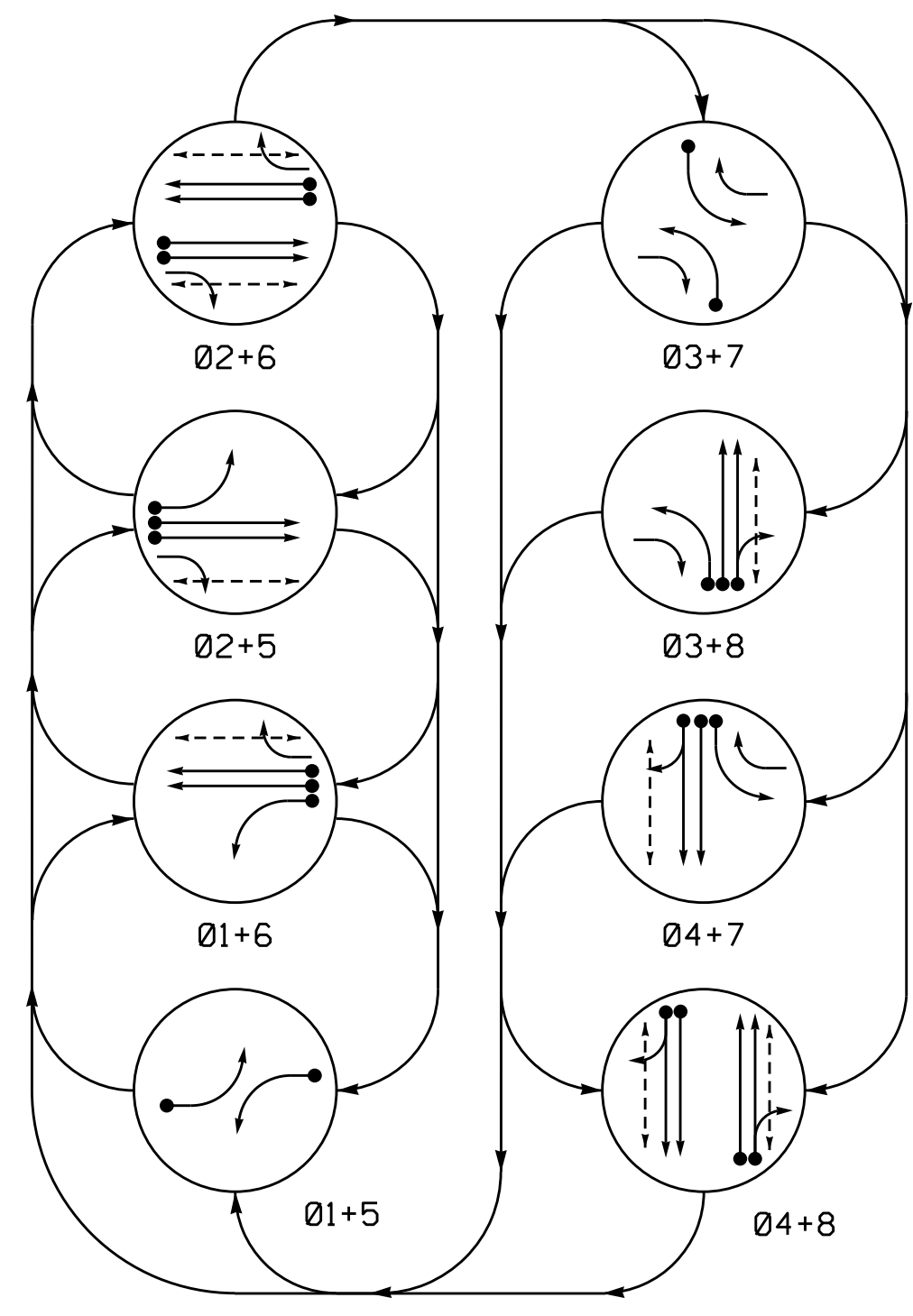

PHASING DIAGRAM DETECTION LEGEND

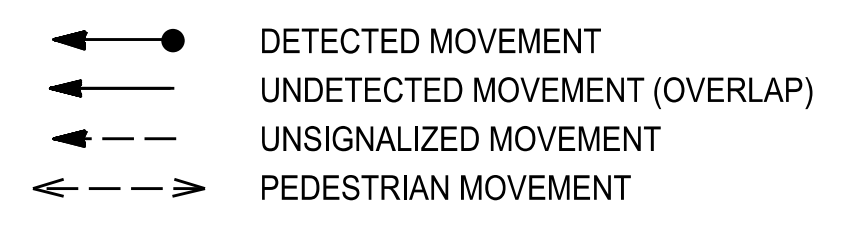

SIGNAL FACE I.D.

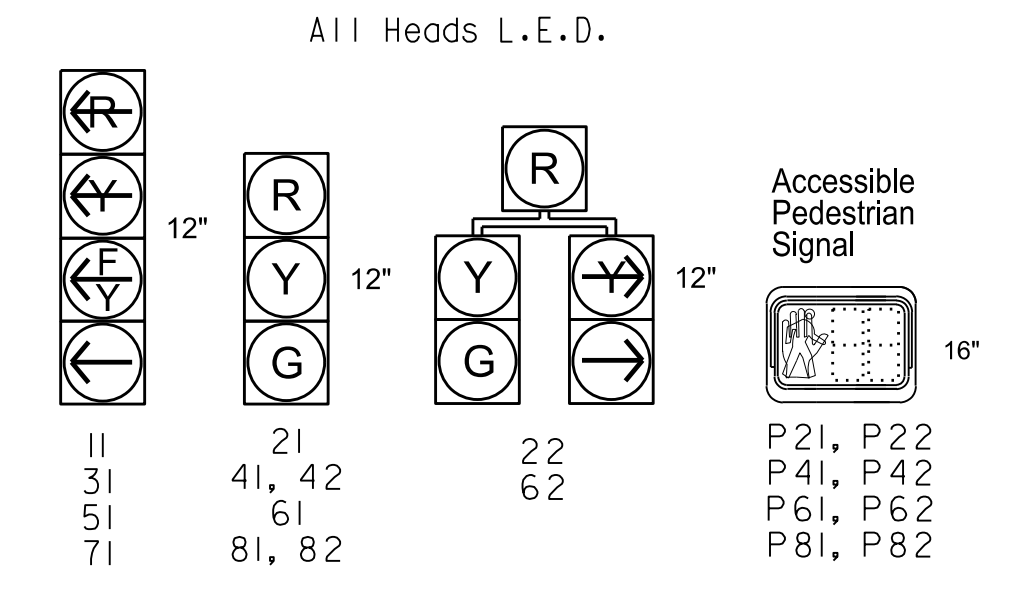

DEFAULT PHASING TABLE OF OPERATION

SIGNAL FACE	PHASE							
	01+5	01+6	02+5	02+6	03+7	03+8	04+7	04+8
11	-	-	-	-	-	-	-	-
21	R	R	G	G	R	R	R	R
22	R	R	G	G	R	R	R	R
31	-	-	-	-	-	-	-	-
41, 42	R	R	R	R	R	R	G	G
51	-	-	-	-	-	-	-	-
61	R	G	R	G	R	R	R	R
62	R	G	R	G	R	R	R	R
71	-	-	-	-	-	-	-	-
81, 82	R	R	R	R	G	G	R	R
P21, P22	DW	DW	W	W	DW	DW	DW	DRK
P41, P42	DW	DW	DW	DW	DW	DW	W	W
P61, P62	DW	W	DW	W	DW	DW	DW	DRK
P81, P82	DW	DW	DW	DW	DW	W	W	DRK

ALTERNATE PHASING TABLE OF OPERATION

SIGNAL FACE	PHASE							
	01+5	01+6	02+5	02+6	03+7	03+8	04+7	04+8
11	-	-	-	-	-	-	-	-
21	R	R	G	G	R	R	R	R
22	R	R	G	G	R	R	R	R
31	-	-	-	-	-	-	-	-
41, 42	R	R	R	R	R	R	G	G
51	-	-	-	-	-	-	-	-
61	R	G	R	G	R	R	R	R
62	R	G	R	G	R	R	R	R
71	-	-	-	-	-	-	-	-
81, 82	R	R	R	R	G	G	R	R
P21, P22	DW	DW	W	W	DW	DW	DW	DRK
P41, P42	DW	DW	DW	DW	DW	DW	W	W
P61, P62	DW	W	DW	W	DW	DW	DW	DRK
P81, P82	DW	DW	DW	DW	W	W	W	DRK

ASC/3 DETECTOR INSTALLATION CHART

LOOP	SIZE (FT)	DISTANCE FROM STOPBAR (FT)	TURNS	NEW LOOP	PROGRAMMING						
					PHASE	CALLING	EXTEND TIME	DELAY TIME	USE ADDED INITIAL	TYPE	LOOP NEW CARD
1A	6X40	0	2-4-2	X	1	Yes	-	15.0**	-	S	-
2A	6X6	300	EXIST	-	2	Yes	-	3.0	-	G	-
2B	6X6	300	EXIST	-	2	Yes	-	-	X	N	-
3A	6X40	0	2-4-2	-	3	Yes	-	10.0*	-	S	-
4A	6X40	0	2-4-2	-	4	Yes	-	-	-	S	-
4B	6X40	0	2-4-2	-	4	Yes	-	10.0	-	S	-
5A	6X40	0	2-4-2	-	5	Yes	-	15.0**	-	S	-
6A	6X6	300	5	X	6	Yes	-	-	X	N	-
6B	6X6	300	5	X	6	Yes	-	-	X	N	-
7A	6X40	0	2-4-2	-	7	Yes	-	10.0*	-	S	-
8A	6X40	0	2-4-2	-	8	Yes	-	-	-	S	-
8B	6X40	0	2-4-2	-	8	Yes	-	10.0	-	S	-

* Disable Delay during Alternate Phasing operation.
 ** Reduce Delay to 3 seconds during Alternate Phasing operation.
 # Disable Phase call for loop during Alternate Phasing operation.

8 Phase Fully Actuated (Durham Signal System)

NOTES

- Refer to "Roadway Standard Drawings NCDOT" dated January 2024 and "Standard Specifications for Roads and Structures" dated January 2024.
- Do not program signal for late night flashing operation unless otherwise directed by the Engineer.
- Phase 1 and/or phase 5 may be lagged.
- Phase 3 and/or phase 7 may be lagged.
- Reposition existing signal head numbered 81.
- Unbag and reconnect existing pedestrian signal heads P61 and P82.
- Set all detector units to presence mode.
- Omit "WALK" and flashing "DON'T WALK" with no pedestrian calls.
- Program pedestrian heads to countdown the flashing "Don't Walk" time only.
- Replace existing pushbuttons with APS Pushbuttons.
- This intersection features accessible pedestrian signals utilizing percussive tone walk indications and/or speech messages.
- Remove existing Right Arrow "ONLY" sign (R3-5R).
- Pavement markings are existing unless otherwise shown.
- The Division (City) Traffic Engineer will determine the hours of use for each phasing plan.
- Maximum times shown in timing chart are for free-run operation only. Coordinated signal system timing values supersede these values.

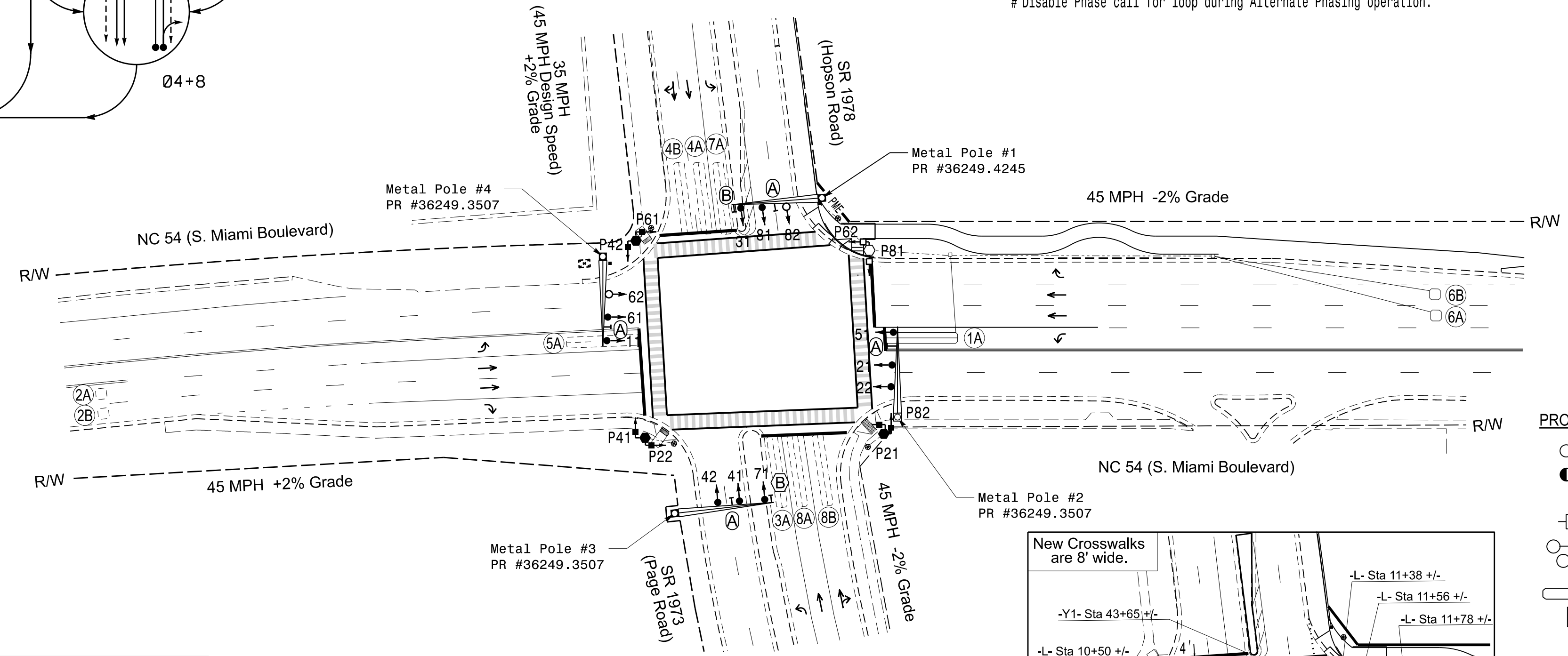

LEGEND

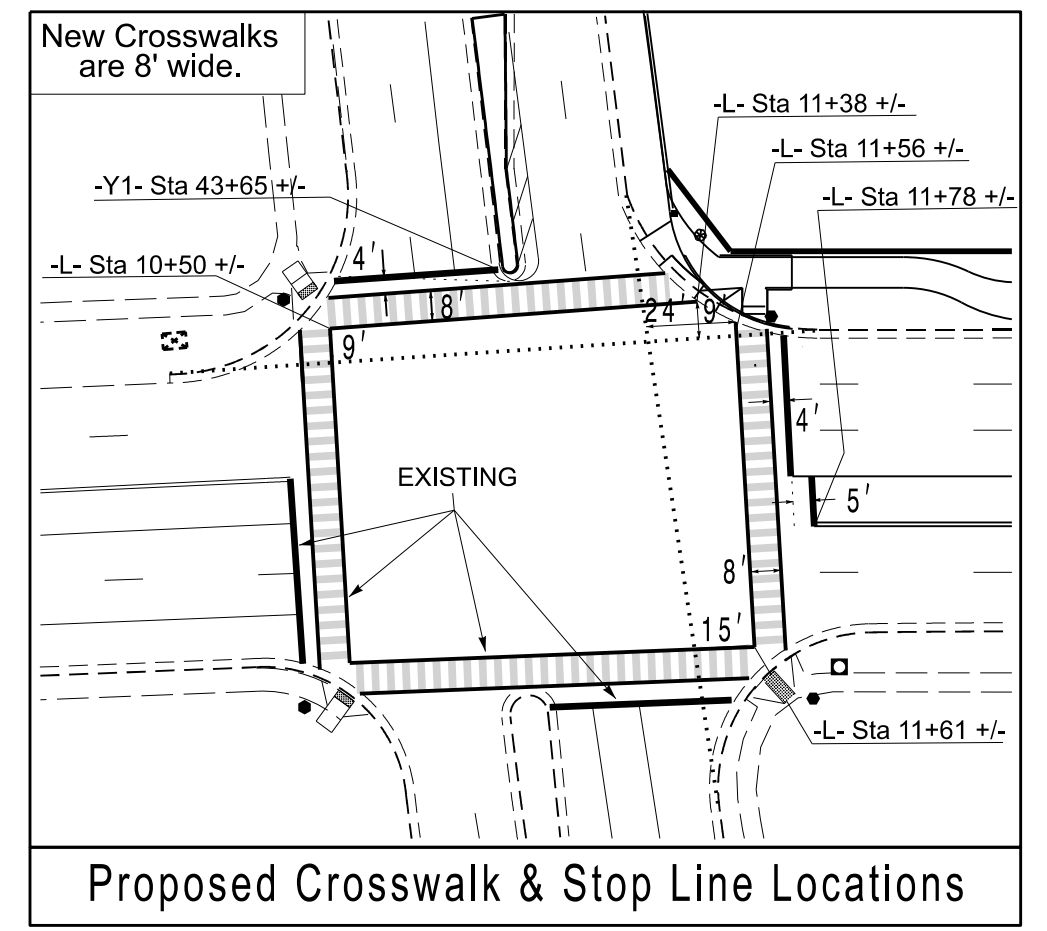
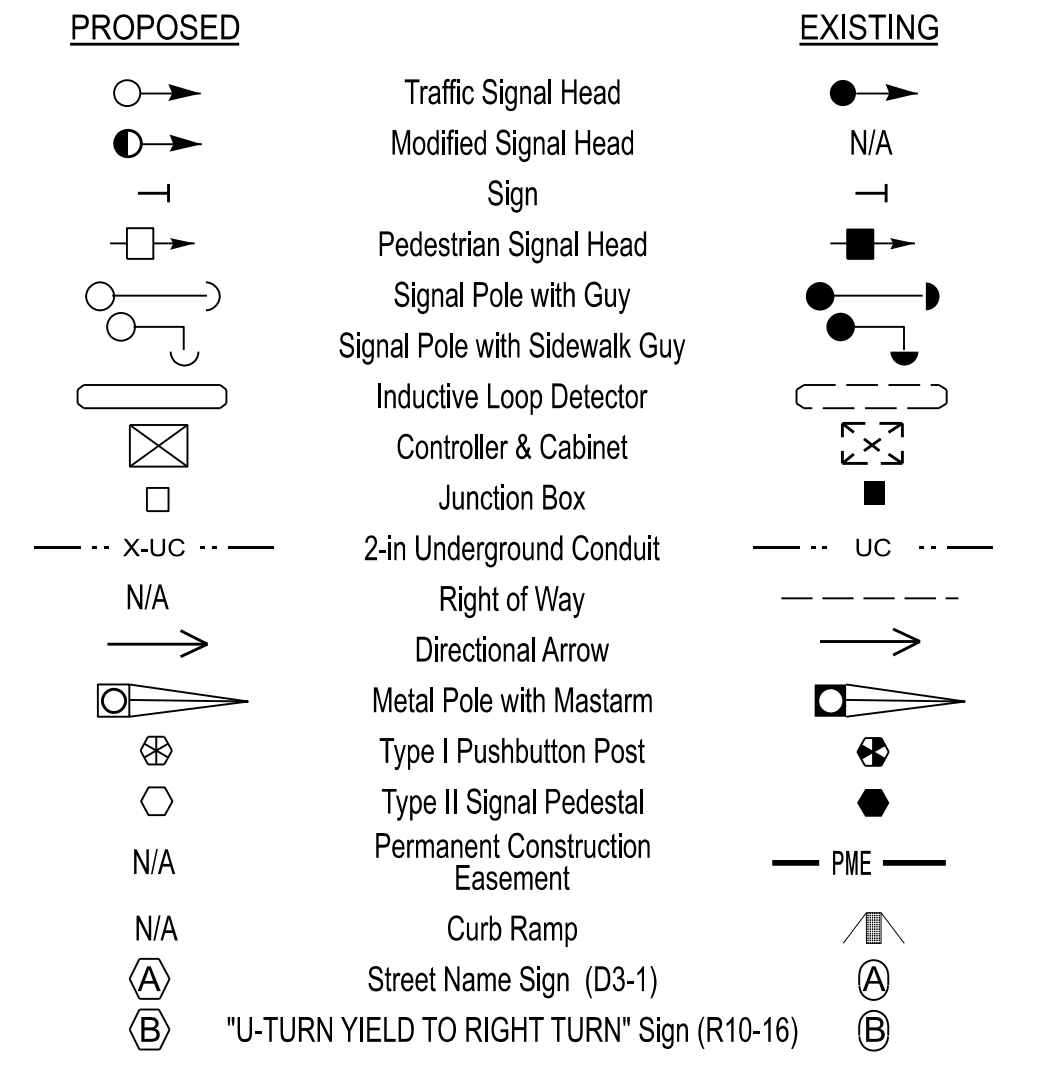

ASC/3 TIMING CHART

FEATURE	PHASE							
	1	2	3	4	5	6	7	8
Min Green *	7	12	7	7	7	12	7	7
Delayed Green	-	7	-	7	-	7	-	7
Walk *	-	7	-	7	-	7	-	7
Ped Clear	-	28	-	24	-	24	-	22
Veh. Extension *	2.0	6.0	2.0	2.0	2.0	6.0	2.0	2.0
Max 1 *	20	90	20	40	20	90	20	40
Yellow	3.0	4.7	3.0	4.7	3.0	4.7	3.0	4.7
Red Clear	3.2	1.9	3.1	2.0	3.1	1.9	3.3	2.0
Red Revert	2.0	2.0	2.0	2.0	2.0	2.0	2.0	2.0
Actuations B4 Add *	-	-	-	-	-	-	-	-
Seconds / Actuation *	-	1.5	-	-	-	1.5	-	-
Max Initial *	-	34	-	-	-	34	-	-
Time Before Reduction *	-	15	-	-	-	15	-	-
Time To Reduce *	-	45	-	-	-	45	-	-
Minimum Gap	-	3.0	-	-	-	3.0	-	-
Locking Detector	-	X	-	-	-	X	-	-
Recall Position	-	VEH. RECALL	-	-	-	VEH. RECALL	-	-
Dual Entry	-	-	-	X	-	-	-	X
Simultaneous Gap	X	X	X	X	X	X	X	X

* These values may be field adjusted. Do not adjust Min Green and Extension times for phases 2 and 6 lower than what is shown. Min Green for all other phases should not be lower than 4 seconds.

ACCESSIBLE PEDESTRIAN SIGNAL OPERATION

SIGNAL FACE	VOICE	TONES	INTERVAL	SPEECH MESSAGE
P21	-	X	Walk	(Percussive Tone)
	X	-	Flashing Don't Walk/Don't Walk	Wait. Wait to cross Page.
P22	-	X	Walk	(Percussive Tone)
	X	-	Flashing Don't Walk/Don't Walk	Wait. Wait to cross Page.
P41	-	X	Walk	(Percussive Tone)
	X	-	Flashing Don't Walk/Don't Walk	Wait. Wait to cross Miami.
P42	-	X	Walk	(Percussive Tone)
	X	-	Flashing Don't Walk/Don't Walk	Wait. Wait to cross Miami.
P61	-	X	Walk	(Percussive Tone)
	X	-	Flashing Don't Walk/Don't Walk	Wait. Wait to cross Hopson.
P62	-	X	Walk	(Percussive Tone)
	X	-	Flashing Don't Walk/Don't Walk	Wait. Wait to cross Hopson.
P81	-	X	Walk	(Percussive Tone)
	X	-	Flashing Don't Walk/Don't Walk	Wait. Wait to cross Miami.
P82	-	X	Walk	(Percussive Tone)
	X	-	Flashing Don't Walk/Don't Walk	Wait. Wait to cross Miami.

Signal Upgrade - Final Design

Prepared in the Offices of:

NC 54 (S. Miami Boulevard) at SR 1978 (Hopson Road) / SR 1973 (Page Road)

Division 5 Durham County Durham

PLAN DATE: April 2025 REVIEWED BY: C.E. Carter

PREPARED BY: C.E. Carter REVIEWED BY: [Signature]

Scale: 1"=50'

DATE: 08/11/2025

SIG. INVENTORY NO. 05-2008

4/25/2025 15:56
 P:\Projects\2025\Signal Upgrade\Signal Design\SM-6105H\Signal Design\SM-6105H\052008_86_dsn_20250811.dgn
 Job Number: 20250811

8 Phase Fully Actuated (Durham Signal System)

NOTES

- Refer to "Roadway Standard Drawings NCDOT" dated January 2024 and "Standard Specifications for Roads and Structures" dated January 2024.
- Do not program signal for late night flashing operation unless otherwise directed by the Engineer.
- Phase 1 and/or phase 5 may be lagged.
- Phase 3 and/or phase 7 may be lagged.
- Reposition existing signal head 81.
- Disconnect and bag existing pedestrian signal heads P61 and P82.
- Set all detector units to presence mode.
- Omit "WALK" and flashing "DON'T WALK" with no pedestrian calls.
- Program pedestrian heads to countdown the flashing "Don't Walk" time only.
- Pavement markings are existing unless otherwise shown.
- The Division (City) Traffic Engineer will determine the hours of use for each phasing plan.
- This intersection uses video detection. Install detectors according to the manufacturer's instructions to achieve the desired detection.
- Maximum times shown in timing chart are for free-run operation only. Coordinated signal system timing values supersede these values.

DEFAULT PHASING DIAGRAM

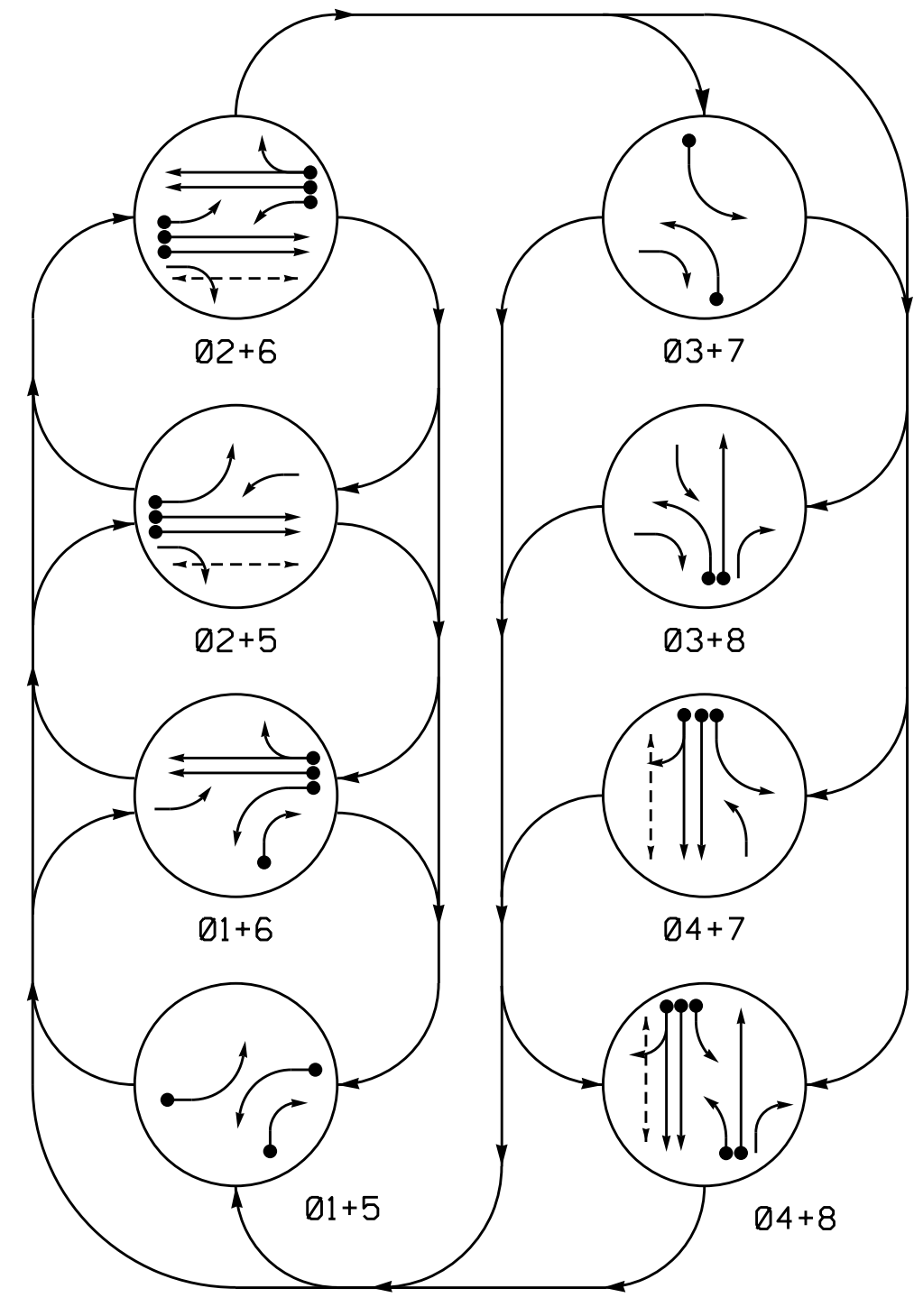

ALTERNATE PHASING DIAGRAM

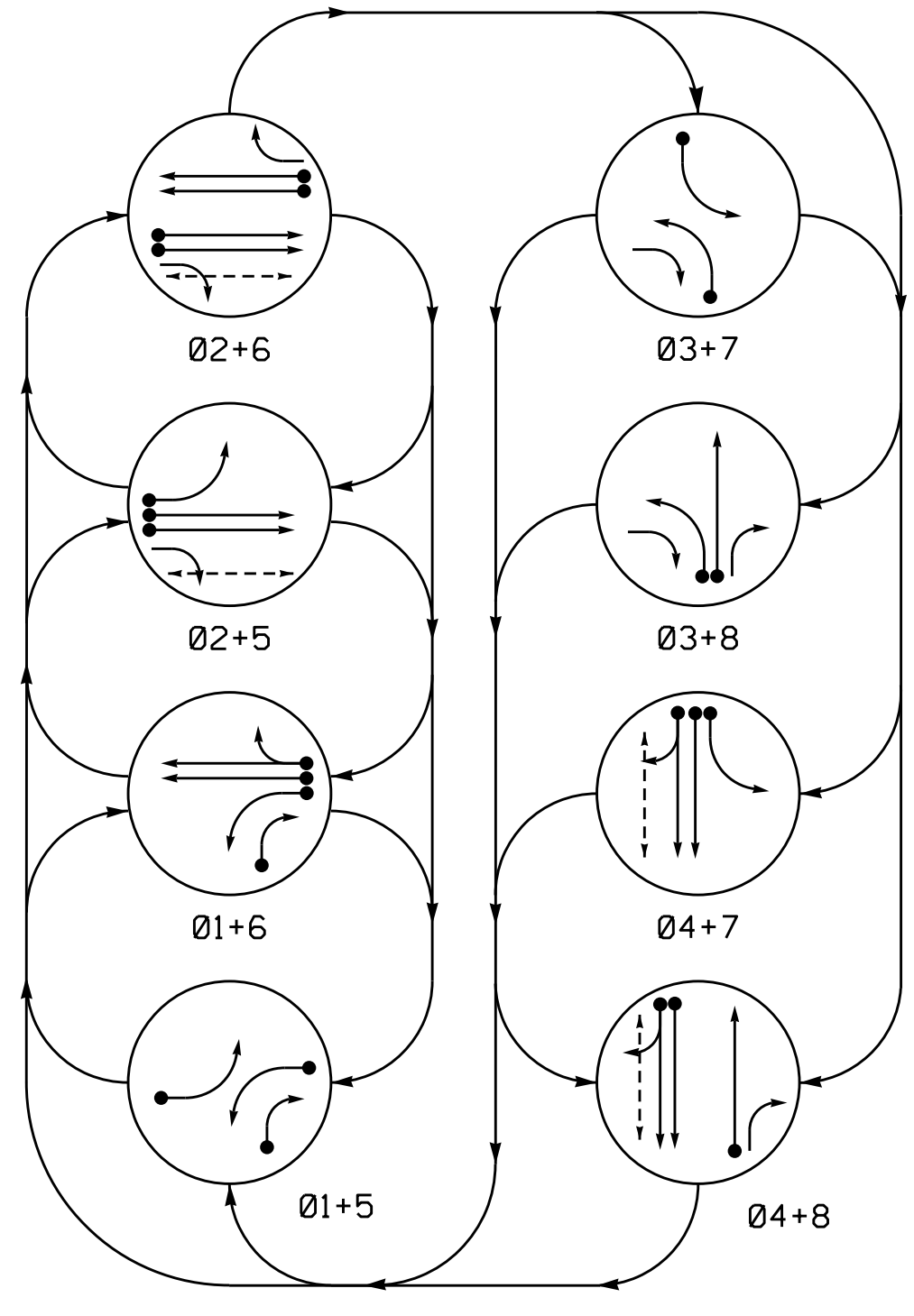

PHASING DIAGRAM DETECTION LEGEND

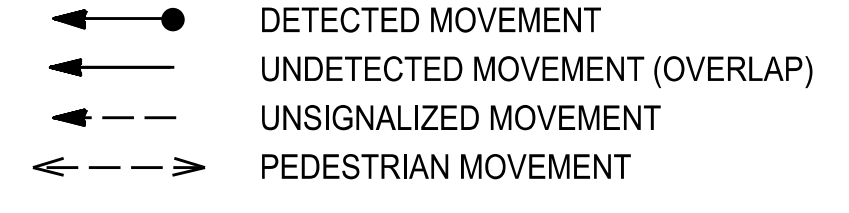

SIGNAL FACE I.D.

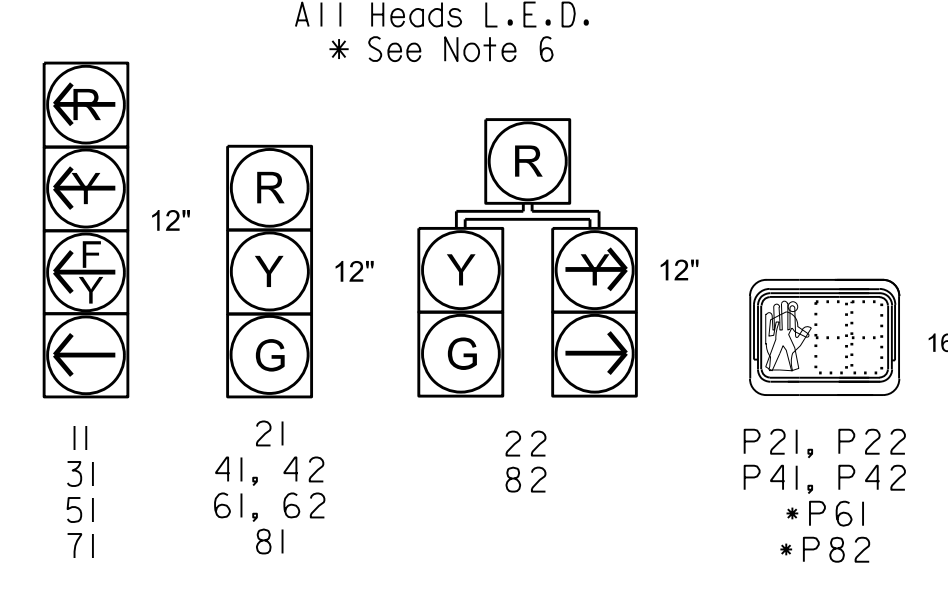

DEFAULT PHASING TABLE OF OPERATION

SIGNAL FACE	PHASE							
	01+5	02+6	03+7	04+8	05+9	06+0	07+1	08+2
11	---	---	---	---	---	---	---	---
21	R	R	G	G	R	R	R	R
22	R	R	G	G	R	R	R	R
31	-R	-R	-R	-R	-R	-R	-R	-R
41, 42	R	R	R	R	R	R	G	G
51	---	---	---	---	---	---	---	---
61, 62	R	G	R	G	R	R	R	R
71	-R	-R	-R	-R	-R	-R	-R	-R
81	R	R	R	R	R	G	R	G
82	R	R	R	R	R	G	R	G
P21, P22	DW	DW	W	W	DW	DW	DW	DRK
P41, P42	DW	DW	DW	DW	DW	W	W	DRK

ALTERNATE PHASING TABLE OF OPERATION

SIGNAL FACE	PHASE							
	01+5	02+6	03+7	04+8	05+9	06+0	07+1	08+2
11	---	---	-R	-R	-R	-R	-R	-R
21	R	R	G	G	R	R	R	R
22	R	R	G	G	R	R	R	R
31	-R	-R	-R	-R	-R	-R	-R	-R
41, 42	R	R	R	R	R	R	G	G
51	---	---	-R	-R	-R	-R	-R	-R
61, 62	R	G	R	G	R	R	R	R
71	-R	-R	-R	-R	-R	-R	-R	-R
81	R	R	R	R	R	G	R	G
82	R	R	R	R	R	G	R	G
P21, P22	DW	DW	W	W	DW	DW	DW	DRK
P41, P42	DW	DW	DW	DW	DW	W	W	DRK

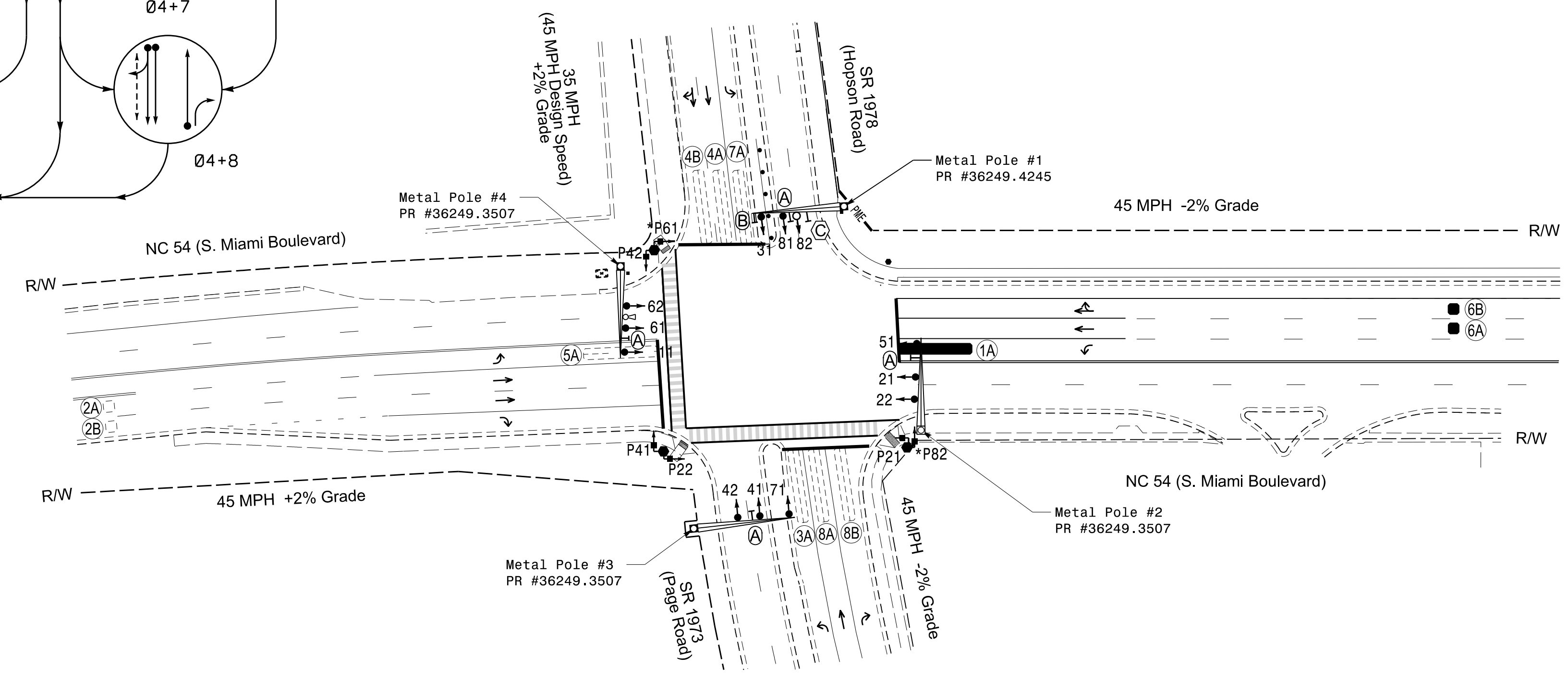

LEGEND

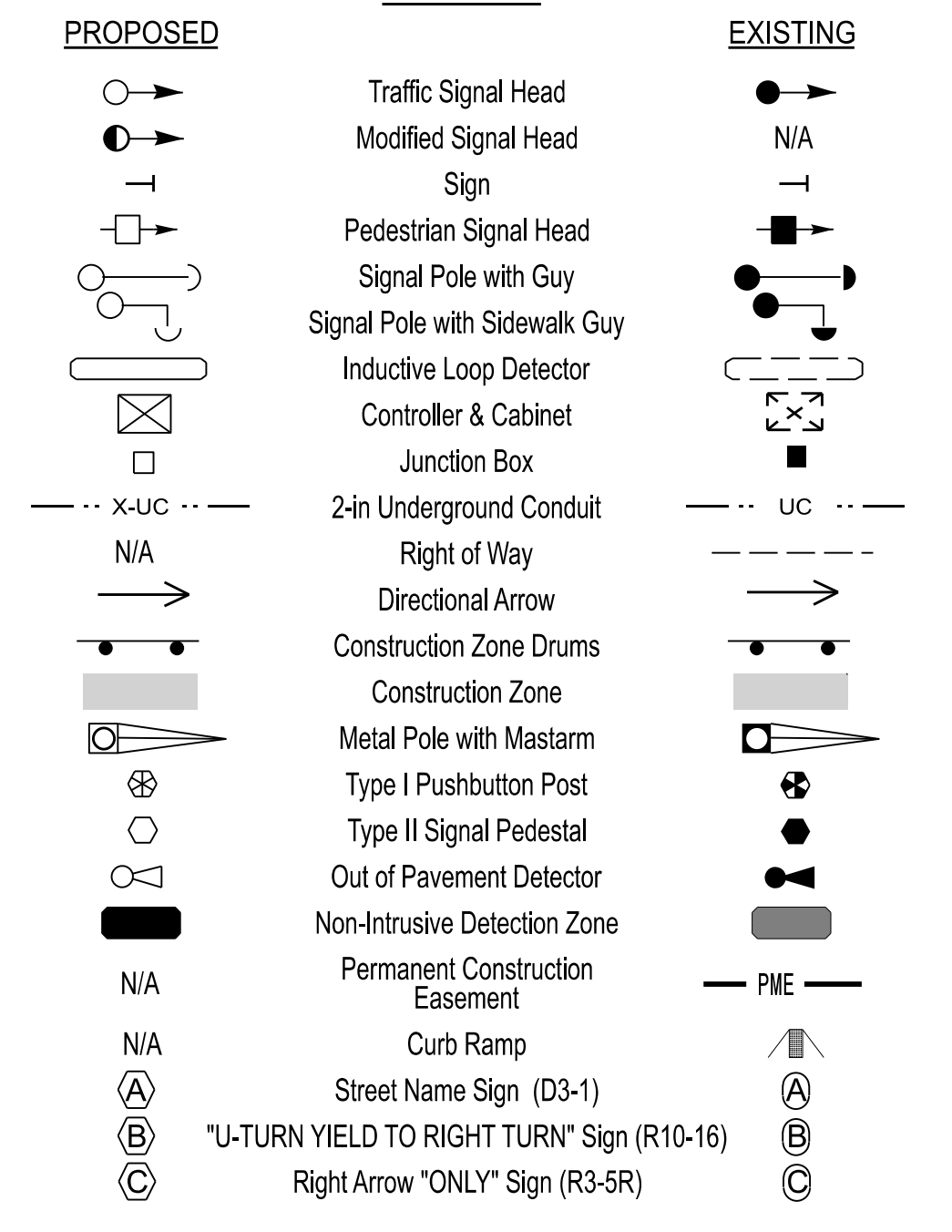

ASC/3 TIMING CHART

FEATURE	PHASE							
	1	2	3	4	5	6	7	8
Min Green *	7	12	7	7	7	12	7	7
Delayed Green	-	7	-	7	-	-	-	-
Walk *	-	14	-	14	-	-	-	-
Ped Clear	-	28	-	24	-	-	-	-
Veh. Extension *	2.0	6.0	2.0	2.0	2.0	6.0	2.0	2.0
Max 1 *	20	90	20	40	20	90	20	40
Yellow	3.0	4.7	3.0	4.7	3.0	4.7	3.0	4.7
Red Clear	3.1	1.9	3.1	1.8	2.8	1.9	3.3	1.8
Red Revert	2.0	2.0	2.0	2.0	2.0	2.0	2.0	2.0
Actuations B4 Add *	-	-	-	-	-	-	-	-
Seconds / Actuation *	-	1.5	-	-	-	1.5	-	-
Max Initial *	-	34	-	-	-	34	-	-
Time Before Reduction *	-	15	-	-	-	15	-	-
Time To Reduce *	-	45	-	-	-	45	-	-
Minimum Gap	-	3.0	-	-	-	3.0	-	-
Locking Detector	-	X	-	-	-	X	-	-
Recall Position	-	VEH. RECALL	-	-	-	VEH. RECALL	-	-
Dual Entry	-	-	-	X	-	-	-	X
Simultaneous Gap	X	X	X	X	X	X	X	X

* These values may be field adjusted. Do not adjust Min Green and Extension times for phases 2 and 6 lower than what is shown. Min Green for all other phases should not be lower than 4 seconds.

ASC/3 DETECTOR INSTALLATION CHART

LOOP/ZONE	SIZE (FT)	DISTANCE FROM STOPBAR (FT)	TURNS	NEW LOOP	PROGRAMMING							
					PHASE	CALLING	EXTEND TIME	DELAY TIME	USE ADDED INITIAL	TYPE	LOOP SYSTEM	NEW CARD
1A##	6X40	0	##	X	1	Yes	-	15.0**	-	S	-	-
2A	6X6	300	EXIST	-	2	Yes	-	3.0	X	N	-	-
2B	6X6	300	EXIST	-	2	Yes	-	-	X	N	-	-
3A	6X40	0	2-4-2	-	3	Yes	-	10.0*	-	S	-	-
4A	6X40	0	2-4-2	-	4	Yes	-	-	-	S	-	-
4B	6X40	0	2-4-2	-	4	Yes	-	10.0	-	S	-	-
5A	6X40	0	2-4-2	-	5	Yes	-	15.0**	-	S	-	-
6A##	6X6	300	##	X	6	Yes	-	-	X	N	-	-
6B##	6X6	300	##	X	6	Yes	-	-	X	N	-	-
7A	6X40	0	2-4-2	-	7	Yes	-	10.0*	-	S	-	-
8A	6X40	0	2-4-2	-	8	Yes	-	-	-	S	-	-
8B	6X40	0	2-4-2	-	1	Yes	-	15.0	-	S	-	-

* Disable Delay during Alternate Phasing operation.
 ** Reduce Delay to 3 seconds during Alternate Phasing operation.
 # Disable Phase call for loop during Alternate Phasing operation.
 ## Non-Intrusive Detection Zone

Signal Upgrade - Temporary Design 1 (TMP Phase II, Steps 1-3)

Prepared in the Offices of:
 Transportation Mobility and Safety Division
 NORTH CAROLINA DEPARTMENT OF TRANSPORTATION
 Signal Design Section

750 N. Greenfield Pkwy, Garner, NC 27529

NC 54 (S. Miami Boulevard)
 at
 SR 1978 (Hopson Road)/
 SR 1973 (Page Road)

Division 5 Durham County Durham

PLAN DATE: June 2025 REVIEWED BY:
 PREPARED BY: C.E. Carter REVIEWED BY:

REVISIONS: INIT. DATE

SCALE: 1"=50'

DocuSigned by: Robert J. Ziemba 08/11/2025

SIG. INVENTORY NO. 05-2008 T1

DOCUMENT NOT CONSIDERED FINAL UNLESS ALL SIGNATURES COMPLETED

SEAL
 NORTH CAROLINA
 PROFESSIONAL ENGINEER
 ROBERT J. ZIEMBA
 ENGINEER
 026486

DEFAULT PHASING DIAGRAM

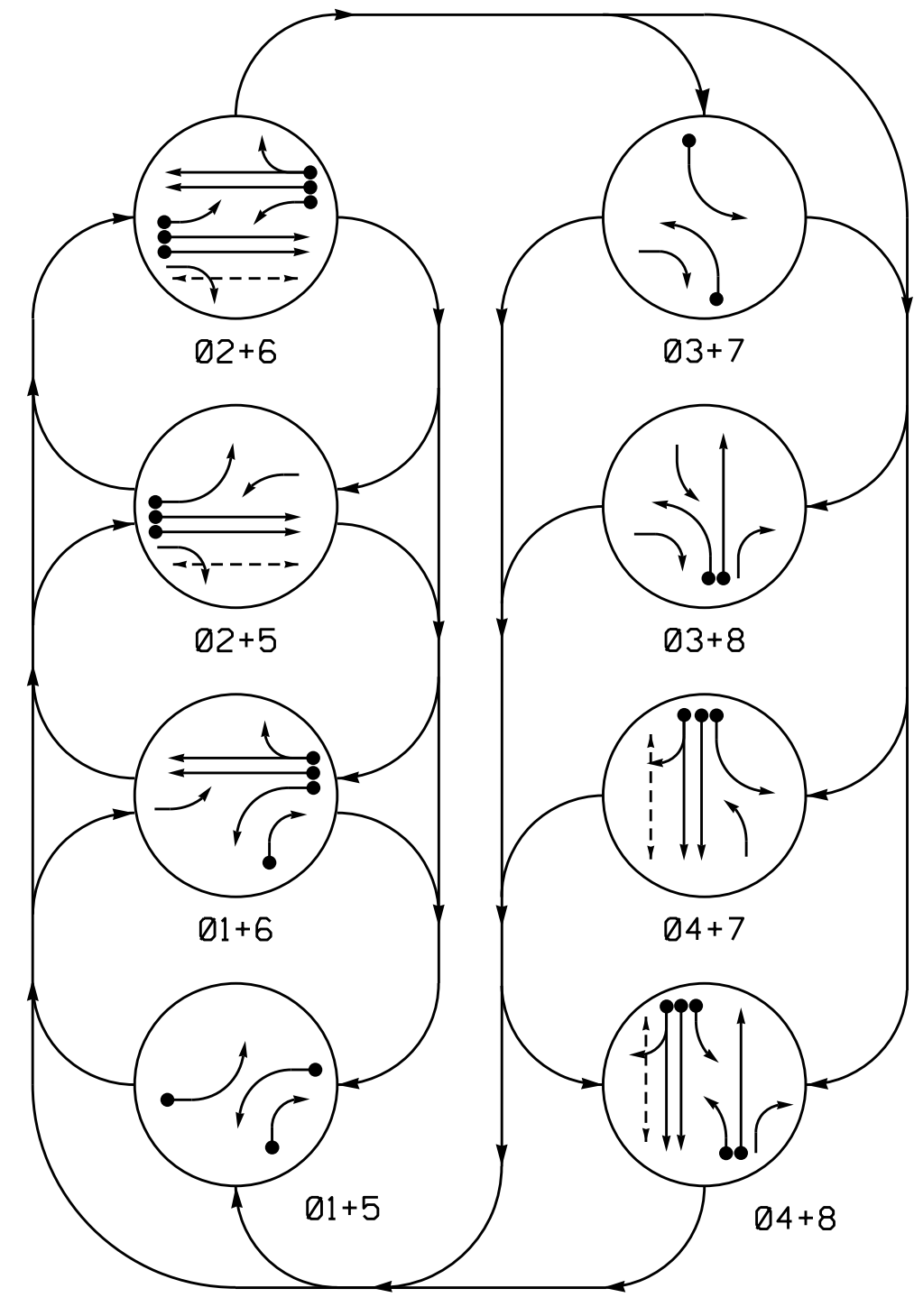

ALTERNATE PHASING DIAGRAM

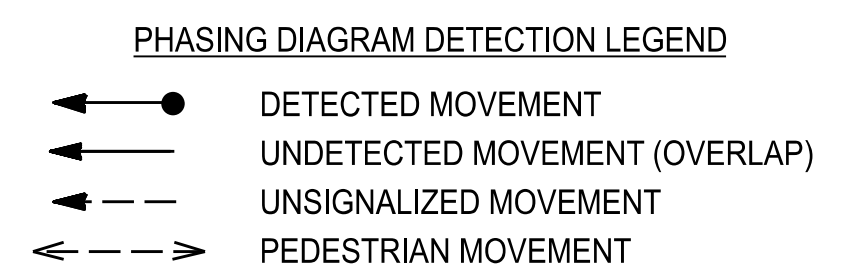
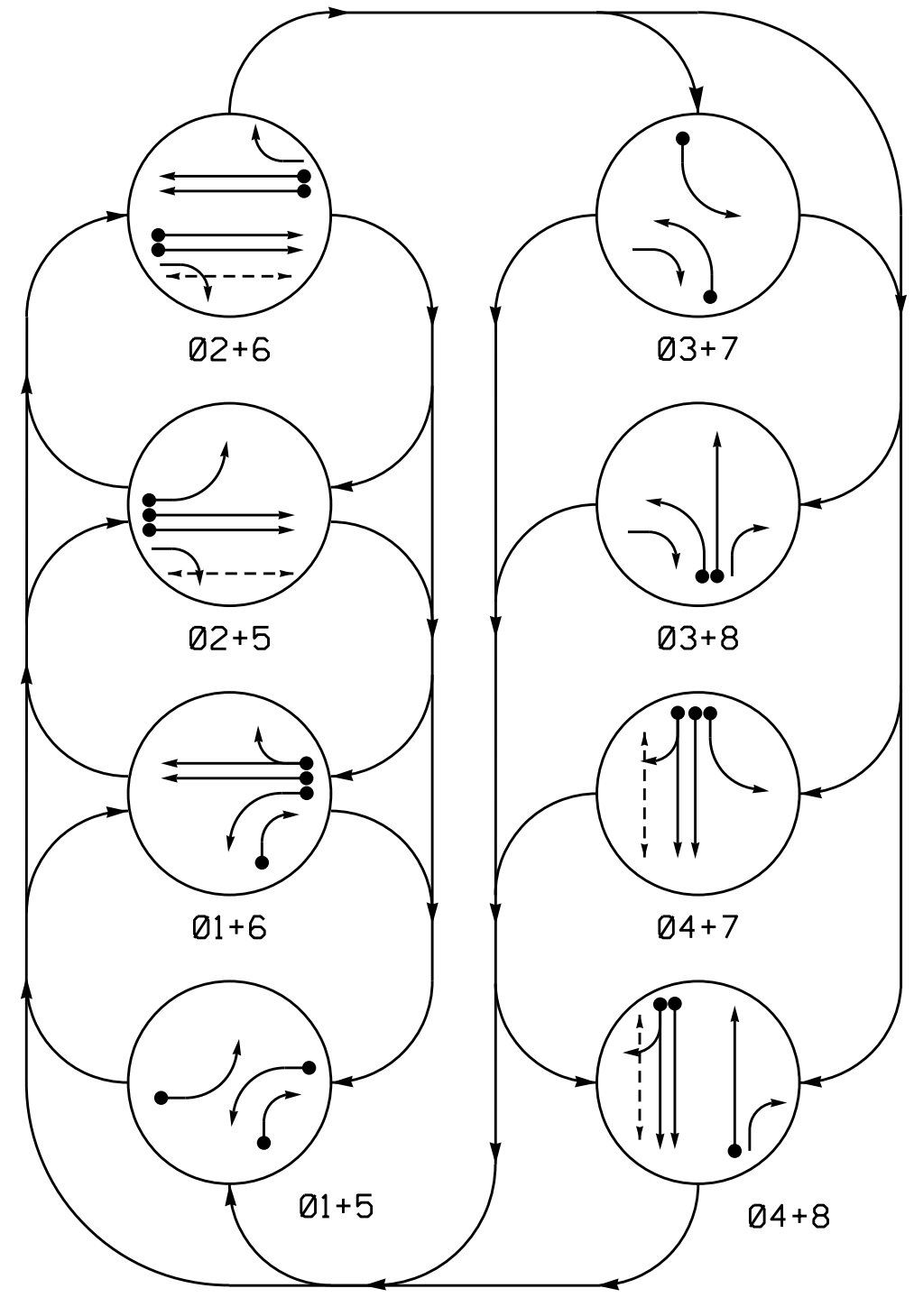

SIGNAL FACE I.D.

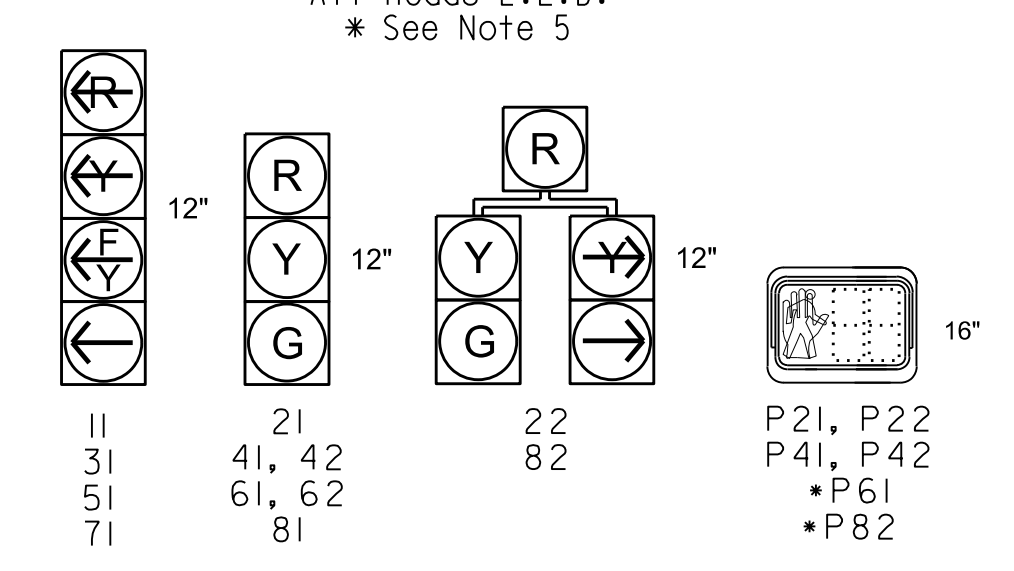

FEATURE	PHASE							
	1	2	3	4	5	6	7	8
Min Green *	7	12	7	7	7	12	7	7
Delayed Green	-	7	-	7	-	-	-	-
Walk *	-	14	-	14	-	-	-	-
Ped Clear	-	28	-	24	-	-	-	-
Veh. Extension *	2.0	6.0	2.0	2.0	2.0	6.0	2.0	2.0
Max 1 *	20	90	20	40	20	90	20	40
Yellow	3.0	4.7	3.0	4.7	3.0	4.7	3.0	4.7
Red Clear	3.1	1.9	3.1	1.8	2.8	1.9	3.3	1.8
Red Revert	2.0	2.0	2.0	2.0	2.0	2.0	2.0	2.0
Actuations B4 Add *	-	-	-	-	-	-	-	-
Seconds / Actuation *	-	1.5	-	-	-	1.5	-	-
Max Initial *	-	34	-	-	-	34	-	-
Time Before Reduction *	-	15	-	-	-	15	-	-
Time To Reduce *	-	45	-	-	-	45	-	-
Minimum Gap	-	3.0	-	-	-	3.0	-	-
Locking Detector	-	X	-	-	-	X	-	-
Recall Position	-	VEH. RECALL	-	-	-	VEH. RECALL	-	-
Dual Entry	-	-	-	X	-	-	-	X
Simultaneous Gap	X	X	X	X	X	X	X	X

* These values may be field adjusted. Do not adjust Min Green and Extension times for phases 2 and 6 lower than what is shown. Min Green for all other phases should not be lower than 4 seconds.

DEFAULT PHASING TABLE OF OPERATION

SIGNAL FACE	PHASE								FLASH
	01+5	01+6	02+5	02+6	03+7	03+8	04+7	04+8	
11	-	-	-	-	-	-	-	-	-
21	R	R	G	G	R	R	R	R	R
22	R	R	G	G	R	R	R	R	R
31	-	-	-	-	-	-	-	-	-
41, 42	R	R	R	R	R	R	G	G	R
51	-	-	-	-	-	-	-	-	-
61, 62	R	G	R	G	R	R	R	R	R
71	-	-	-	-	-	-	-	-	-
81	R	R	R	R	G	R	G	R	R
82	R	R	R	R	G	R	G	R	R
P21, P22	DW	DW	W	W	DW	DW	DW	DRK	DRK
P41, P42	DW	DW	DW	DW	DW	W	W	DRK	DRK

ALTERNATE PHASING TABLE OF OPERATION

SIGNAL FACE	PHASE								FLASH
	01+5	01+6	02+5	02+6	03+7	03+8	04+7	04+8	
11	-	-	-	-	-	-	-	-	-
21	R	R	G	G	R	R	R	R	R
22	R	R	G	G	R	R	R	R	R
31	-	-	-	-	-	-	-	-	-
41, 42	R	R	R	R	R	R	G	G	R
51	-	-	-	-	-	-	-	-	-
61, 62	R	G	R	G	R	R	R	R	R
71	-	-	-	-	-	-	-	-	-
81	R	R	R	R	G	R	G	R	R
82	R	R	R	R	G	R	G	R	R
P21, P22	DW	DW	W	W	DW	DW	DW	DRK	DRK
P41, P42	DW	DW	DW	DW	DW	W	W	DRK	DRK

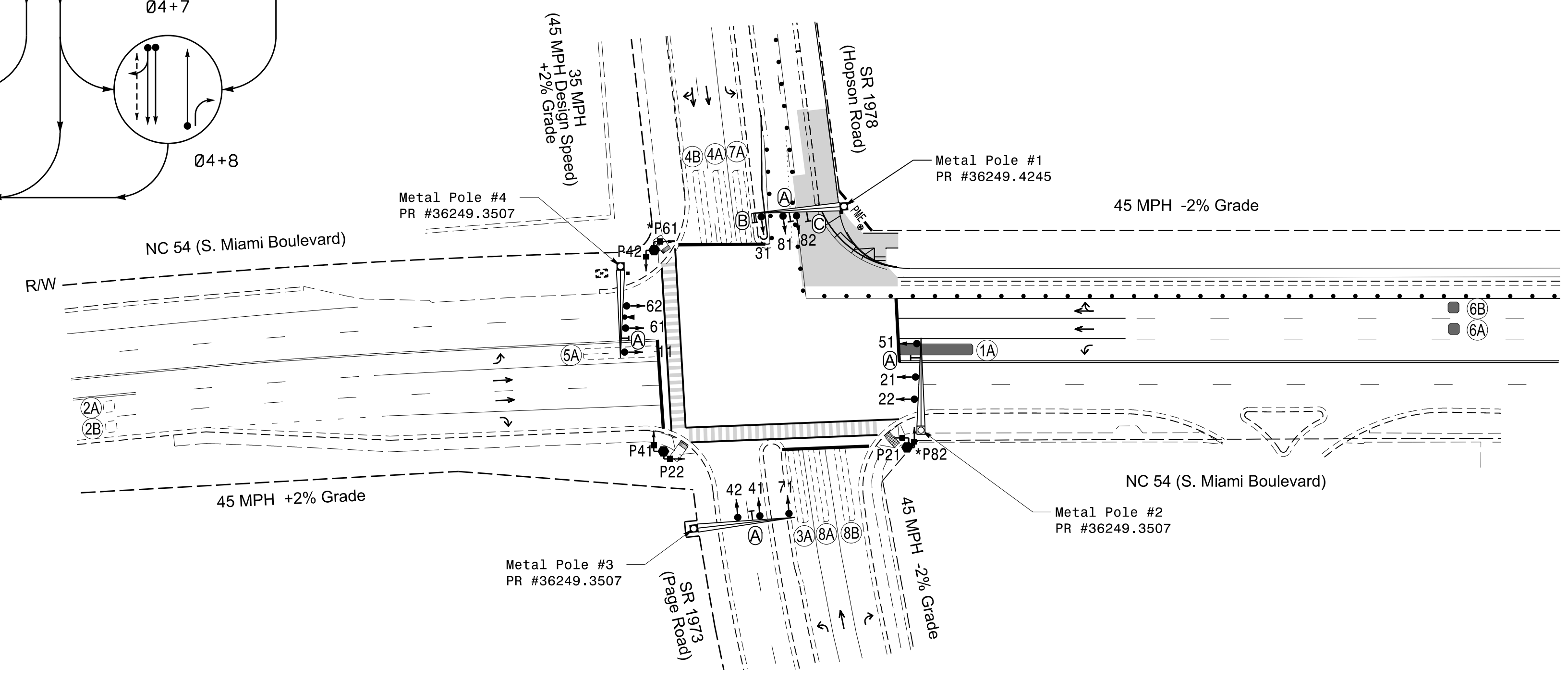

8 Phase Fully Actuated (Durham Signal System)

NOTES

- Refer to "Roadway Standard Drawings NCDOT" dated January 2024 and "Standard Specifications for Roads and Structures" dated January 2024.
- Do not program signal for late night flashing operation unless otherwise directed by the Engineer.
- Phase 1 and/or phase 5 may be lagged.
- Phase 3 and/or phase 7 may be lagged.
- Existing pedestrian signal heads P61 and P82 are bagged.
- Set all detector units to presence mode.
- Omit "WALK" and flashing "DON'T WALK" with no pedestrian calls.
- Program pedestrian heads to countdown the flashing "Don't Walk" time only.
- Pavement markings are existing.
- The Division (City) Traffic Engineer will determine the hours of use for each phasing plan.
- This intersection uses video detection. Install detectors according to the manufacturer's instructions to achieve the desired detection.
- Maximum times shown in timing chart are for free-run operation only. Coordinated signal system timing values supersede these values.

LEGEND

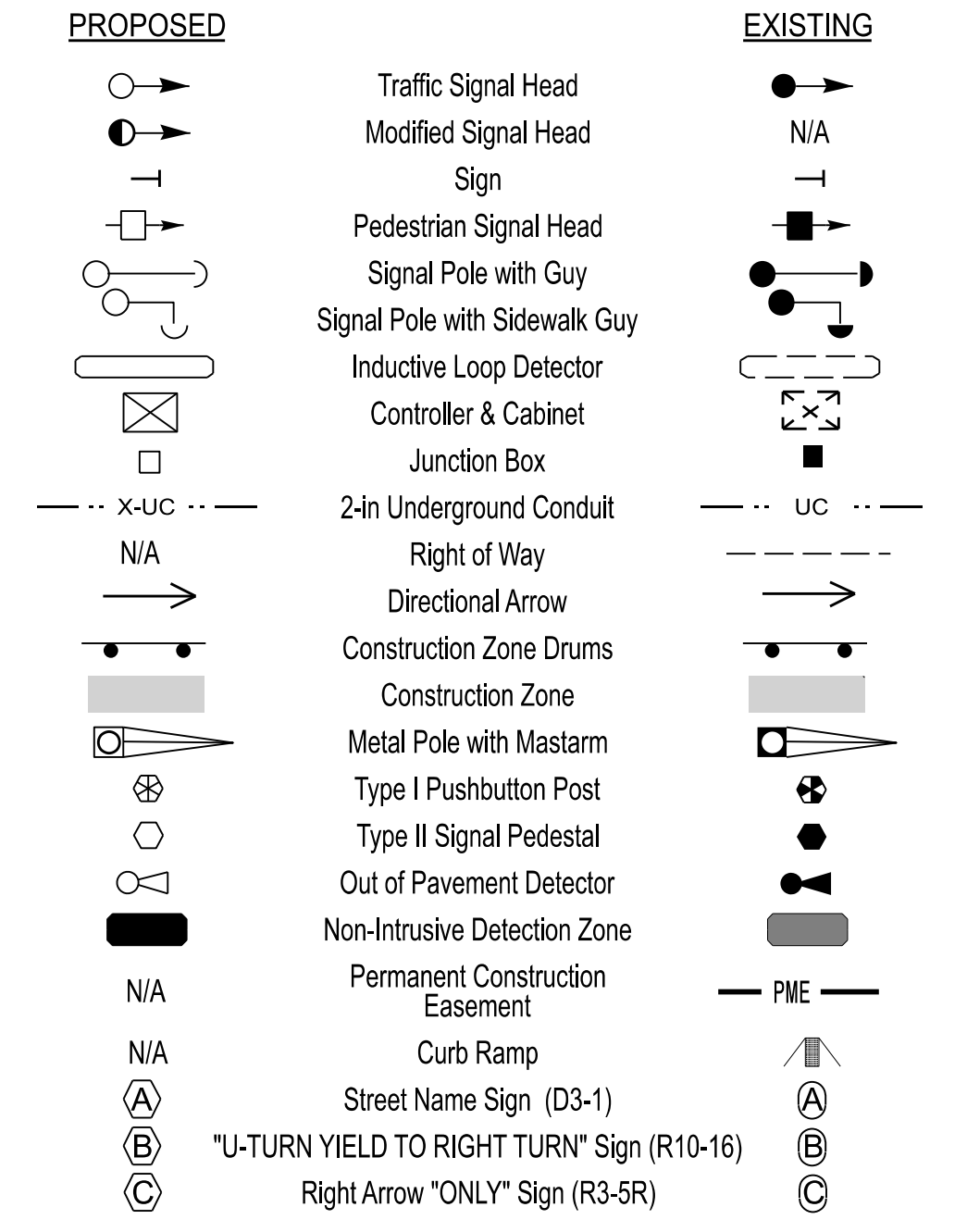

ASC/3 DETECTOR INSTALLATION CHART

LOOP/ZONE	SIZE (FT)	DISTANCE FROM STOPBAR (FT)	TURNS	NEW LOOP	PROGRAMMING							
					PHASE	CALLING	EXTEND TIME	DELAY TIME	USE ADDED INITIAL	TYPE	LOOP SYSTEM	NEW CARD
1A##	6X40	0	##	X	1	Yes	-	15.0**	-	S	-	-
2A	6X6	300	EXIST	-	2	Yes	-	-	X	N	-	-
2B	6X6	300	EXIST	-	2	Yes	-	-	X	N	-	-
3A	6X40	0	2-4-2	-	3	Yes	-	10.0*	-	S	-	-
4A	6X40	0	2-4-2	-	4	Yes	-	-	-	S	-	-
4B	6X40	0	2-4-2	-	4	Yes	-	10.0	-	S	-	-
5A	6X40	0	2-4-2	-	5	Yes	-	15.0**	-	S	-	-
6A##	6X6	300	##	X	6	Yes	-	-	X	N	-	-
6B##	6X6	300	##	X	6	Yes	-	-	X	N	-	-
7A	6X40	0	2-4-2	-	7	Yes	-	10.0*	-	S	-	-
8A	6X40	0	2-4-2	-	8	Yes	-	-	-	S	-	-
8B	6X40	0	2-4-2	-	1	Yes	-	15.0	-	S	-	-

* Disable Delay during Alternate Phasing operation.
** Reduce Delay to 3 seconds during Alternate Phasing operation.
Disable Phase call for loop during Alternate Phasing operation.
Non-Intrusive Detection Zone

Signal Upgrade - Temporary Design 2 (TMP Phase II, Step 4)

Prepared in the Offices of:
Transportation Mobility and Safety Division
NORTH CAROLINA DEPARTMENT OF TRANSPORTATION
Signal Design Section

NC 54 (S. Miami Boulevard) at SR 1978 (Hopson Road)/ SR 1973 (Page Road)

Division 5 Durham County Durham

PLAN DATE: June 2025 REVIEWED BY:
PREPARED BY: C.E. Carter REVIEWED BY:

REVISIONS: INIT. DATE

SCALE: 1"=50'

DOCUMENT NOT CONSIDERED FINAL UNLESS ALL SIGNATURES SEALS COMPLETED

SEAL
NORTH CAROLINA PROFESSIONAL ENGINEER
ROBERT J. ZEMBA
026486
08/11/2025
SIG. INVENTORY NO. 05-2008 T2

CONTRACT: SM-5705AG

STATE OF NORTH CAROLINA
DIVISION OF HIGHWAYS

WAKE COUNTY
UTILITIES BY OTHERS PLANS

LOCATION: NC 98 (DURHAM RD.) AT SR1005 (SIX FORKS RD.)
TYPE OF WORK: COMMUNICATIONS RELOCATION

T.I.P. NO.	SHEET NO.
SM-5705AG	UO-1

NOTE:
ALL UTILITY WORK SHOWN ON THIS SHEET WILL BE DONE BY OTHERS.
NO PAYMENT WILL BE MADE TO THE CONTRACTOR FOR UTILITY WORK SHOWN ON THIS SHEET.

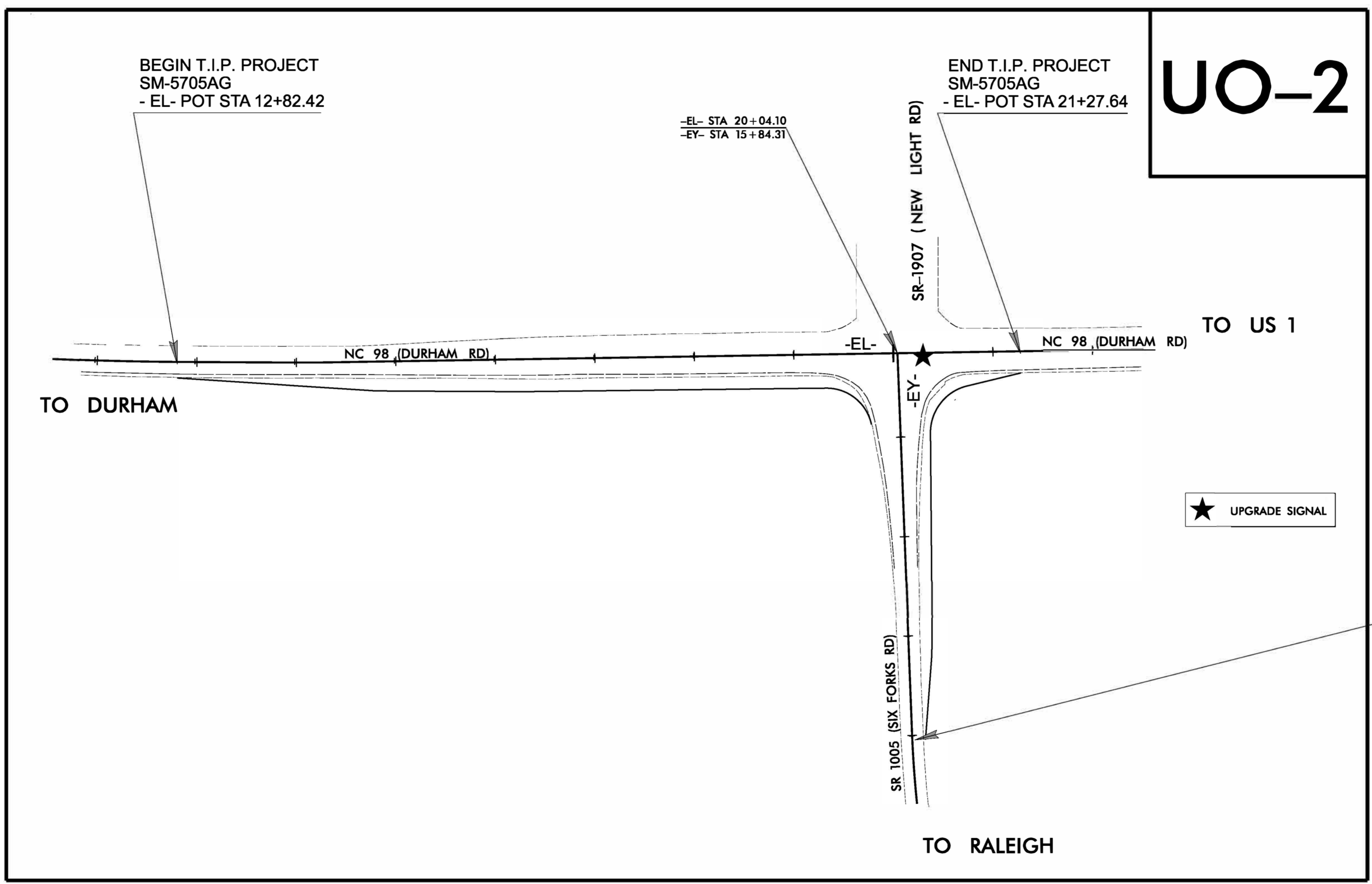
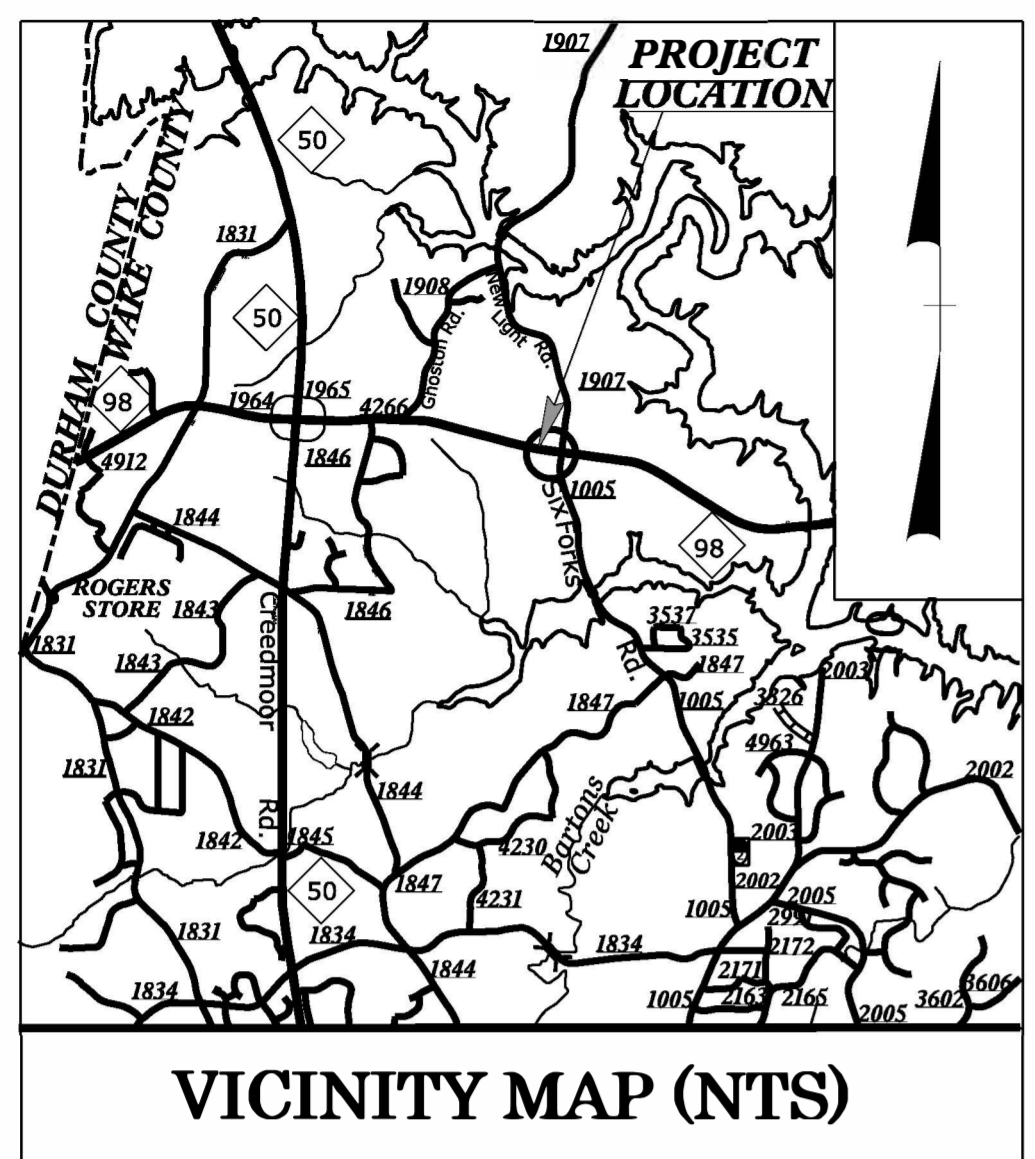

THIS PROJECT IS NOT WITHIN ANY MUNICIPAL BOUNDARIES

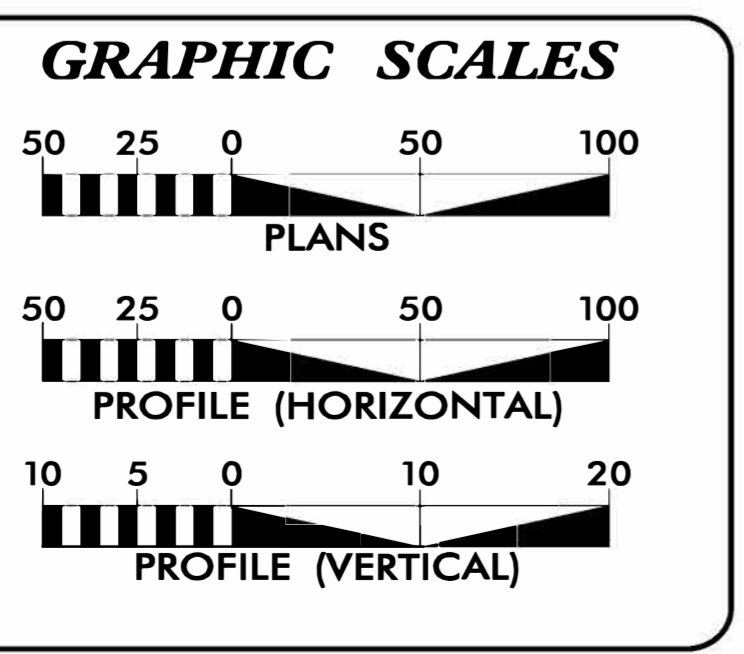

INDEX OF SHEETS

SHEET NO.:	DESCRIPTION:
UO-1	TITLE SHEET
UO-2	UBO PLAN SHEET

UTILITY OWNERS WITH CONFLICTS

(A) COMMUNICATIONS- CHARTER/SPECTRUM
(B) COMMUNICATIONS - AT&T DISTRIBUTION

PREPARED IN THE OFFICE OF:

Pennoni ASSOCIATES INC.
5430 WADE PARK BLVD., SUITE 106,
RALEIGH, NC 27607 PHONE: 919.929.1173
FAX: 919.493.6548 NC LICENSE #F-1267

BRIAN WILES, PE	UTILITY PROJECT MANAGER
ERIC TWEED, PE	PROJECT UTILITY COORDINATOR
LEVI SMITH	PROJECT UTILITY COORDINATOR

DIVISION OF HIGHWAYS
DIVISION 5
PROJECT DEVELOPMENT UNIT
2612 N. DUKE STREET
DURHAM, NC 27704
PHONE (919) 317-4700
FAX (919) 317-4710

SUSAN LANCASTER, PE	TEAM LEAD
MATTHEW NOLFO, PE	PROJECT MANAGER
DON W. PROPER	DIVISION UTILITIES ENGINEER
JAMES SWINSON	UTILITES ENGINEER

UTILITIES BY OTHERS



PENNONI ASSOCIATES INC.
 5430 WADE PARK BLVD., SUITE 106,
 RALEIGH, NC 27607 PHONE: 919.929.1173
 FAX: 919.493.6548 NC LICENSE #F-1267

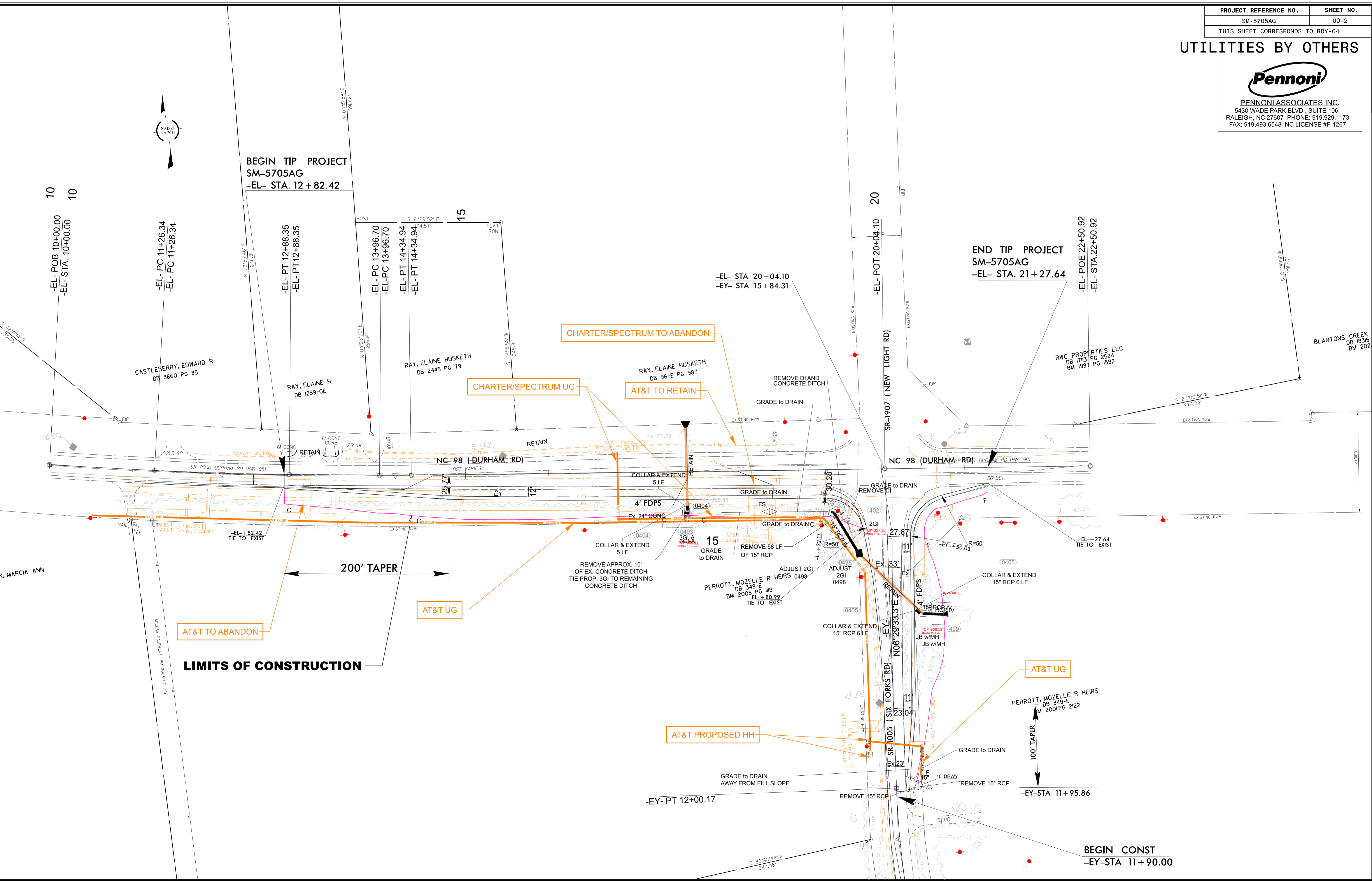

BEGIN TIP PROJECT
 SM-5705AG
 -EL- STA. 12 + 82.42

END TIP PROJECT
 SM-5705AG
 -EL- STA. 21 + 27.64

LIMITS OF CONSTRUCTION

BEGIN CONST
 -EY-STA 11 + 90.00

CHARTER/SPECTRUM TO ABANDON

CHARTER/SPECTRUM UG

AT&T TO RETAIN

AT&T TO ABANDON

AT&T UG

AT&T PROPOSED HH

AT&T UG

10
 -EL- POB 10+00.00
 -EL- STA. 10+00.00

-EL- PC 11+26.34
 -EL- PC 11+26.34

-EL- PT 12+88.35
 -EL- PT 12+88.35

-EL- PC 13+96.70
 -EL- PC 13+96.70

-EL- PT 14+34.94
 -EL- PT 14+34.94

15

-EL- STA 20 + 04.10
 -EY- STA 15 + 84.31

20

-EL- POT 20+04.10

-EL- POE 22+50.92
 -EL- STA. 22+50.92

BLANTONS CREEK
 DB 1835
 BM 202

RWC PROPERTIES LLC
 DB 1713 PG 2524
 BM 1997 PG 1592

CASTLEBERRY, EDWARD R
 DB 3860 PG 85

RAY, ELAINE H
 DB 1259-0E

RAY, ELAINE HUSKETH
 DB 2445 PG 79

RAY, ELAINE HUSKETH
 DB 96-E PG 987

ANN, MARCIA

200' TAPER

REMOVE APPROX. 10'
 OF EX. CONCRETE DITCH
 TIE PROP. 3GI TO REMAINING
 CONCRETE DITCH

PERROTT, MOZELLE R HEIRS
 DB 349-E
 BM 2005 PG 119
 -EL- + 80.99
 TIE TO EXIST

PERROTT, MOZELLE R HEIRS
 DB 349-E
 BM 2001 PG 2122

100' TAPER

-EY- PT 12+00.17

-EY- STA 11 + 95.86

S 85°48'44" W
 243.45'

S 00°48'11" W
 291.53'

S 87°00'51" W
 215.24'

N 03°55'46" E
 63.5818'

N 04°23'20" E
 295.144'

S 81°29'52" E
 74.57'

S 04°15'58" W
 249.81'



VARIED

SR-1907 (NEW LIGHT RD)

NC 98 (DURHAM RD)

SR-1005 (SIX FORKS RD)

N06293333E

ACCESS EASEMENT (10' MIN. WID. 500' LONG)

ADJ. TO AT&T CORP., FO

ADJ. TO AT&T CORP., FO

ADJ. TO AT&T CORP., FO

CONTRACT: DE00419 TIP PROJECT: SM-6105H / HS-2405AH

See Sheet UO-2 For Conventional Symbols

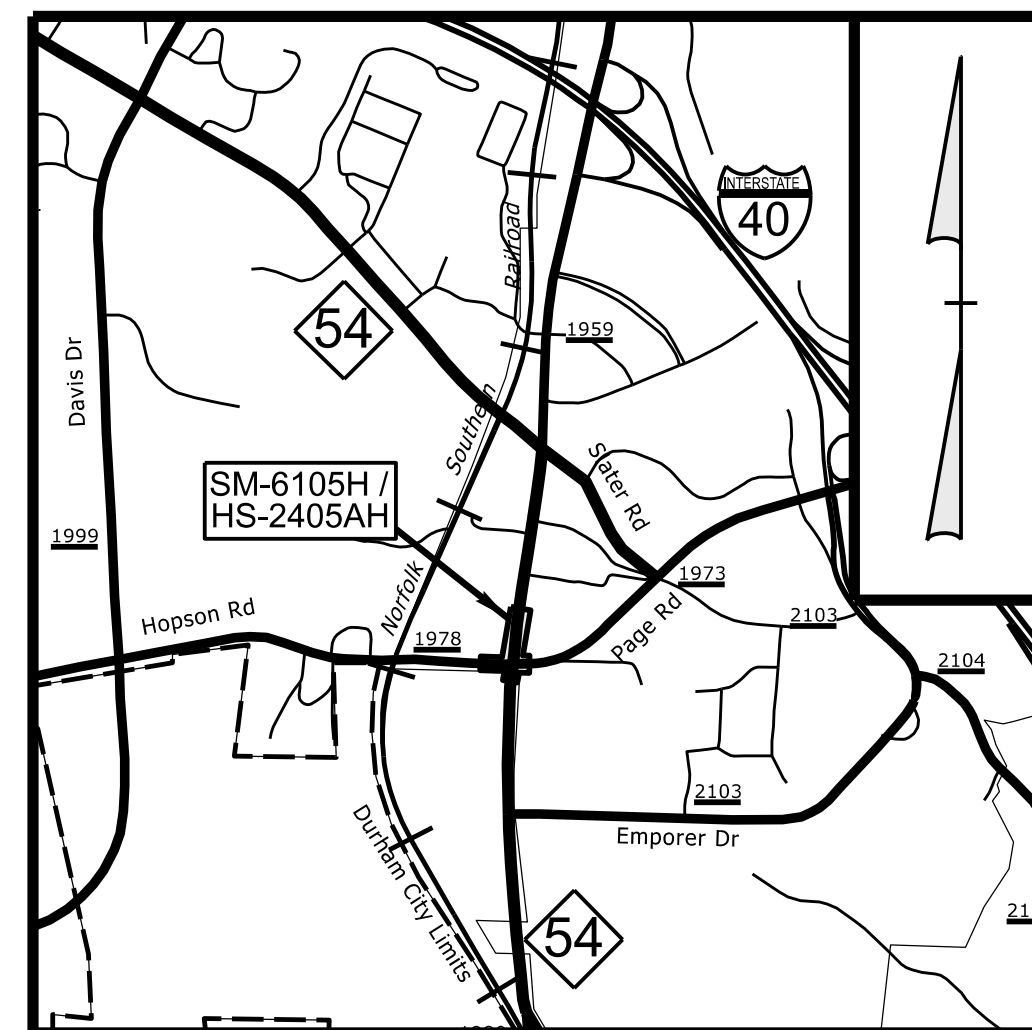

VICINITY MAP (NTS)

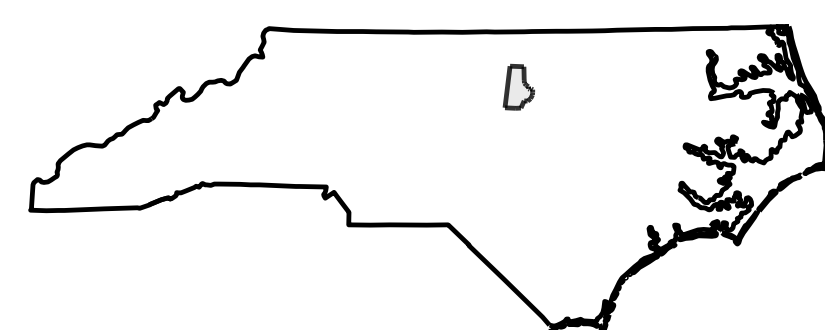

STATE OF NORTH CAROLINA
DIVISION OF HIGHWAYS

**UTILITIES BY OTHERS PLANS
DURHAM COUNTY**

LOCATION: NC 54 (S. MIAMI BLVD.) AT SR 1978 (HOPSON RD.)
CONSTRUCT A SOUTHBOUND RIGHT TURN LANE
ON NC 54

TYPE OF WORK: COMMUNICATIONS RELOCATION

T.I.P. NO.	SHEET NO.
SM-6105H / HS-2405AH	UO-1

NOTE:
ALL UTILITY WORK SHOWN ON THESE SHEETS WILL BE DONE BY OTHERS.
NO PAYMENT WILL BE MADE TO THE CONTRACTOR FOR UTILITY WORK SHOWN ON THESE SHEETS.

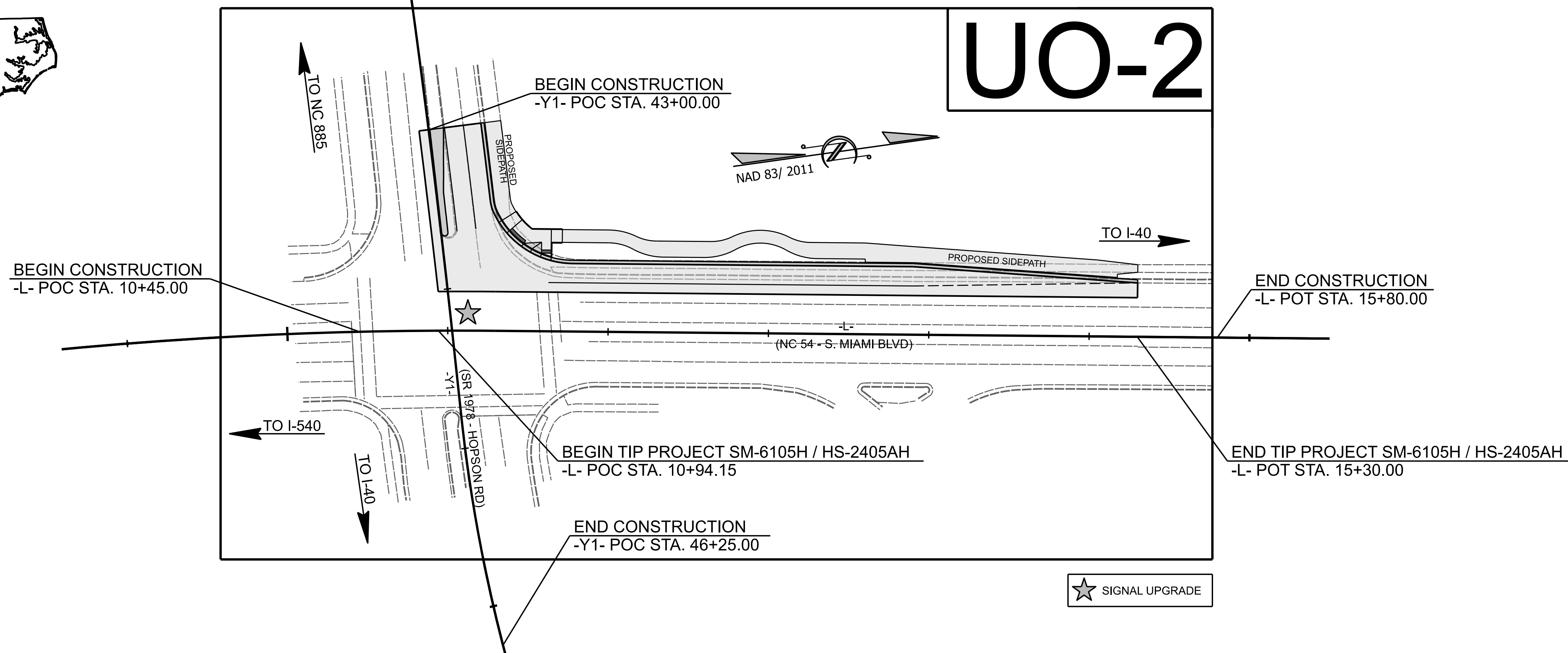

DOCUMENT NOT CONSIDERED FINAL
UNLESS ALL SIGNATURES COMPLETED

GRAPHIC SCALES

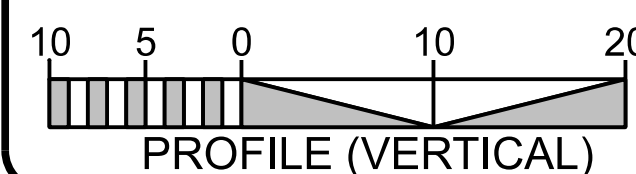
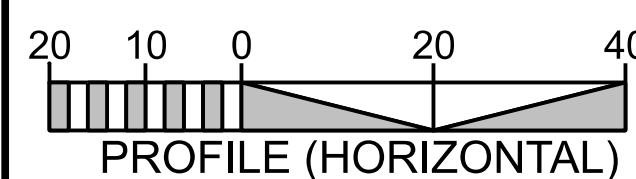
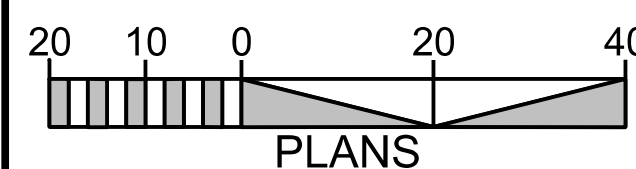

INDEX OF SHEETS

SHEET NO.:	DESCRIPTION:
UO-1	TITLE SHEET
UO-2	UTILITIES BY OTHERS PLAN SHEET

2024 STANDARD SPECIFICATIONS

UTILITY OWNERS WITH CONFLICTS

- A) CROWN CASTLE
- B) VERIZON
- C) SPECTRUM

Plans Prepared in the Office of:



220 HORIZON DRIVE, SUITE 117
RALEIGH, NC 27615
PHONE (727) 214-7698
LICENSE NO. P-2673
WWW.VIASINFRASTRUCTURE.COM

CONSULTANT CONTACT #1 MATTHEW DOUGLAS, PE

CONSULTANT CONTACT #2 NICK RAMIREZ, PE

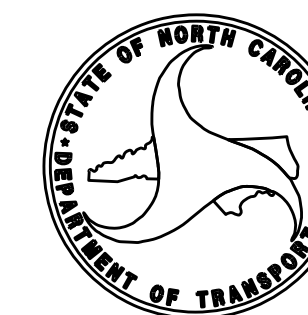

Prepared for:

DIVISION OF HIGHWAYS
DIVISION 5
PROJECT DEVELOPMENT UNIT

2612 NORTH DUKE STREET
DURHAM, NC 27704
PHONE (919) 317-4700
FAX (919) 317-4710

SUSAN LANCASTER, PE

MATTHEW NOLFO, PE

DONALD W. PROPER

JAMES SWINSON

DIVISION 5 TEAM LEAD

DIVISION 5 PROJECT MANAGER

DIVISION 5 UTILITIES ENGINEER

UTILITIES ENGINEER

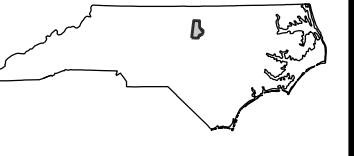

ALL PROPOSED UTILITY WORK SHOWN ON THIS SHEET WILL BE DONE BY OTHERS. NO PAYMENT WILL BE MADE TO THE CONTRACTOR FOR UTILITY WORK SHOWN ON THIS SHEET.

DOCUMENT NOT CONSIDERED FINAL UNLESS ALL SIGNATURES COMPLETED.

ROADWAY DESIGN PREPARED BY

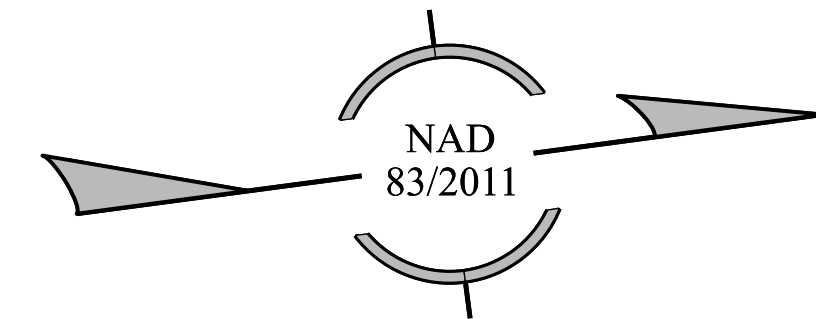

BEGIN CONSTRUCTION
-Y1- POC STA. 43+00.00

END RESURFACING
-Y1- POC STA. 44+01.59

BEGIN TIP PROJECT SM-6105H / HS-2405AH
-L- POC STA. 10+94.15

BEGIN CONSTRUCTION
-L- POC STA. 10+45.00

END TIP PROJECT SM-6105H / HS-2405AH
-L- POT STA. 15+30.00

END CONSTRUCTION
-Y1- POC STA. 46+25.00

CURVE DATA		
CUR DATA -L- Plc 9+89.89 Δc = 06°09'34.7" (RT) D = 02°12'13.3"	CUR DATA -Y1- Plc 42+65.83 Δc = 02°37'53.6" (RT) D = 00°47'36.9"	CUR DATA -Y1- Plc 47+25.73 Δc = 28°03'13.1" (LT) D = 05°50'47.4"
Lc = 279.52	Lc = 331.61	Lc = 479.84
Tc = 139.89	Tc = 165.83	Tc = 244.83
R = 2,600	R = 7,220	R = 980
SE = EXIST.	SE = EXIST.	SE = EXIST.
RO = EXIST.	RO = EXIST.	RO = EXIST.

CONTRACTOR TO TAKE GREAT CARE AND PRECAUTIONS WHEN GRADING AROUND EXISTING UTILITY POLES AND GUY WIRES.

NOTE: CONTRACTOR NOT TO DISTURB EXISTING FENCE AND BRICK COLUMNS ADJACENT TO WORK AREA. NO CONSTRUCTION ACTIVITIES TO TAKE PLACE WITHIN EXISTING FENCED OFF AREA.

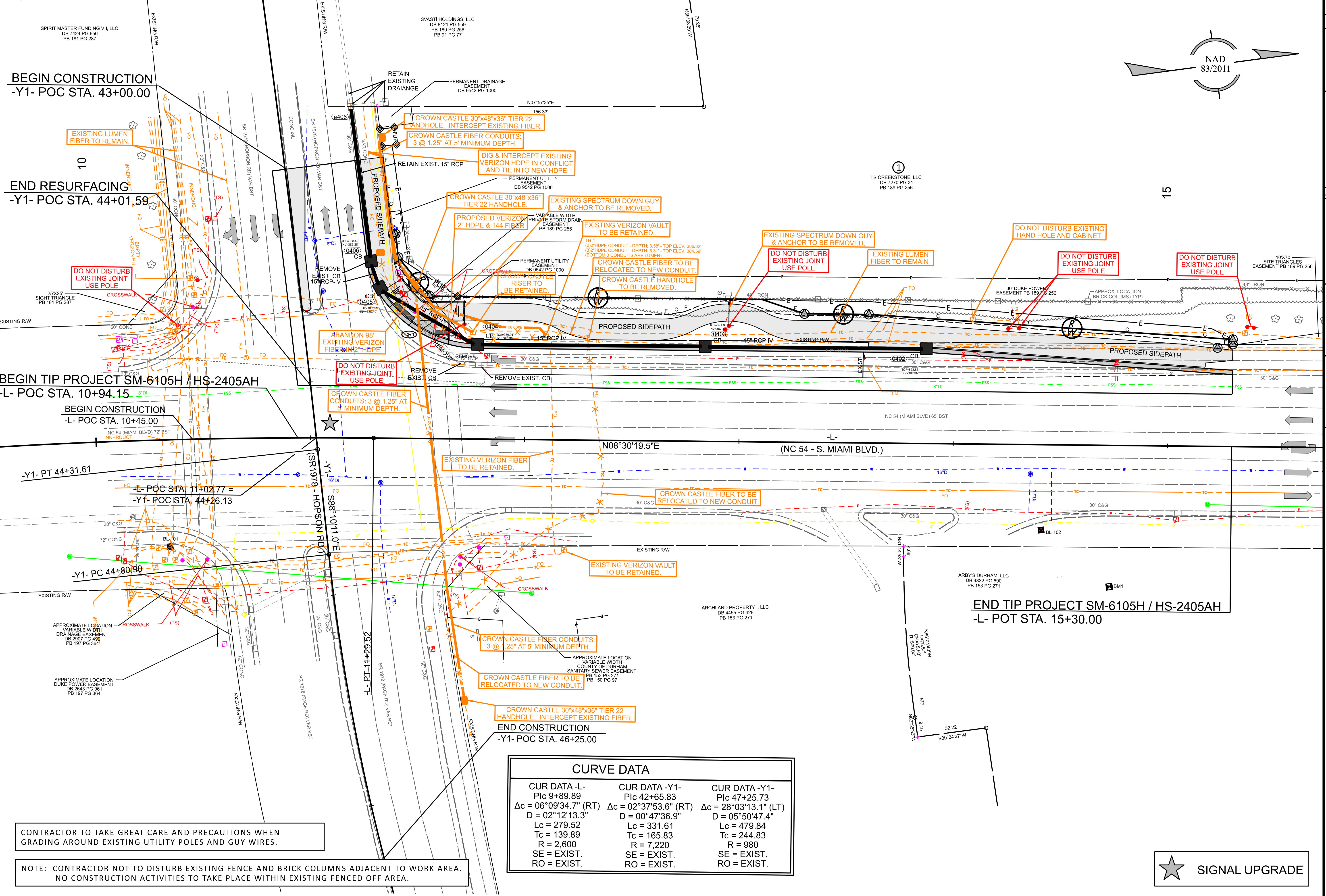

REVISIONS

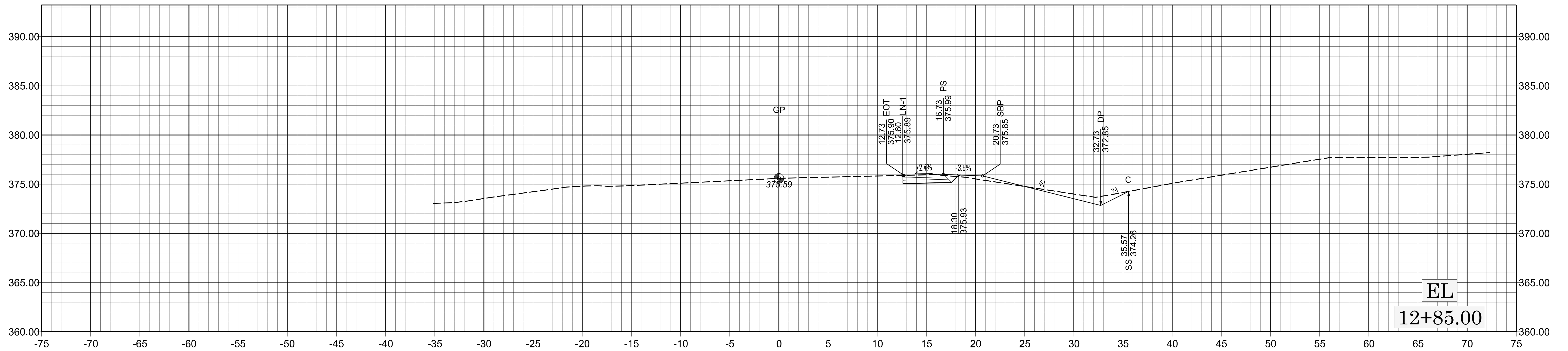
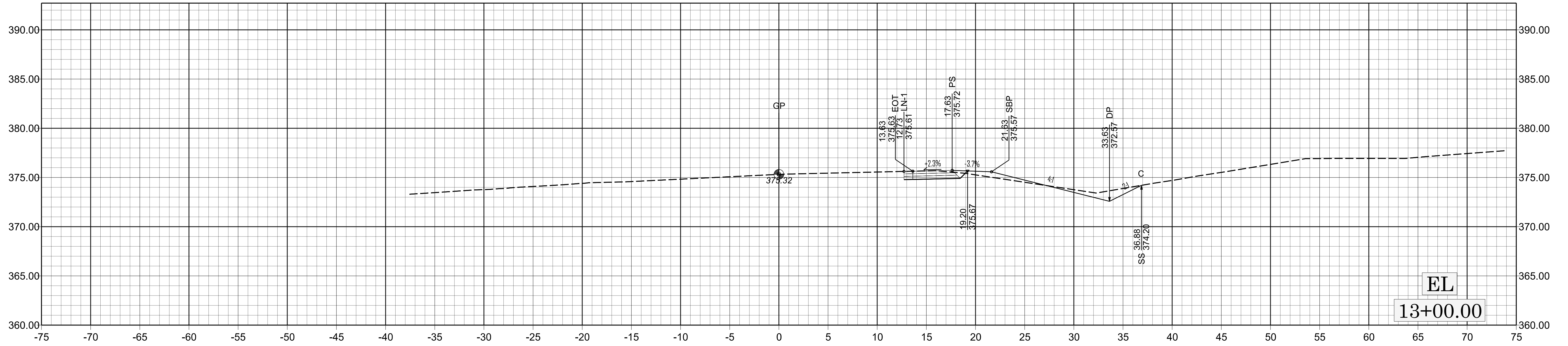
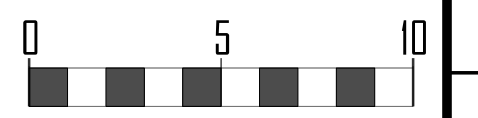

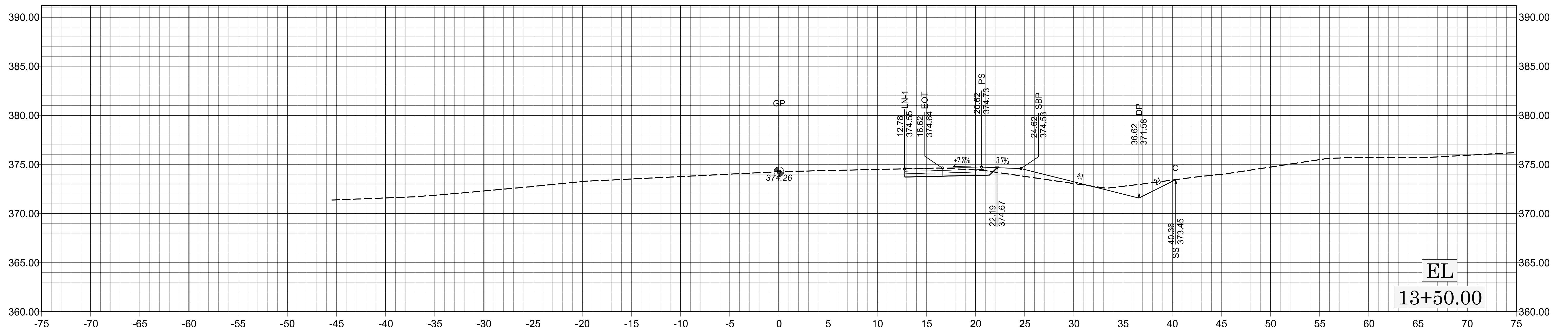
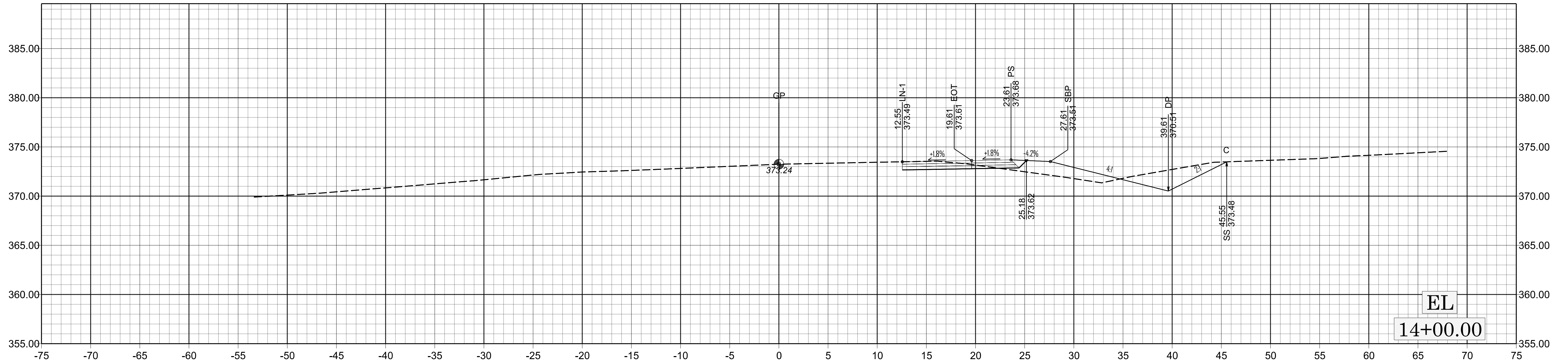

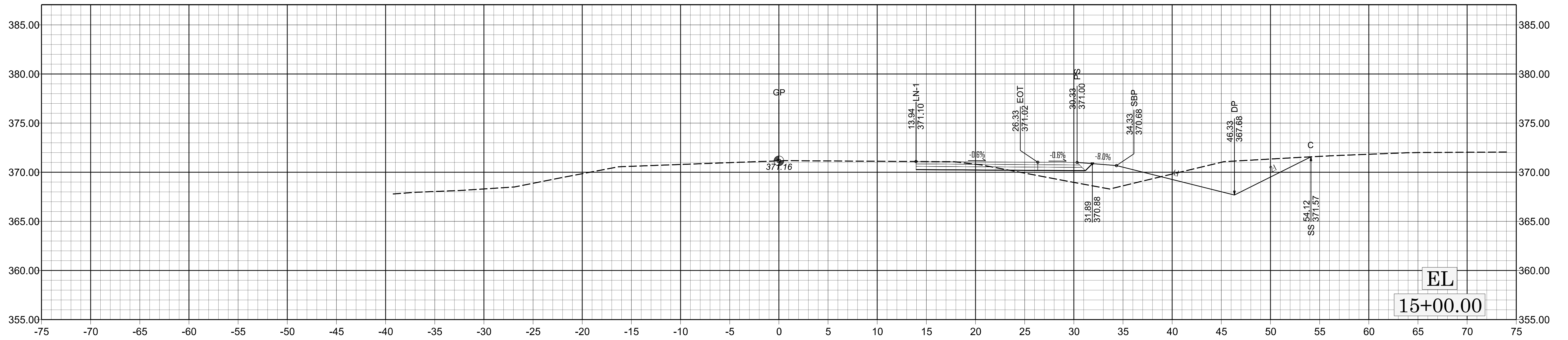

EL
15+00.00

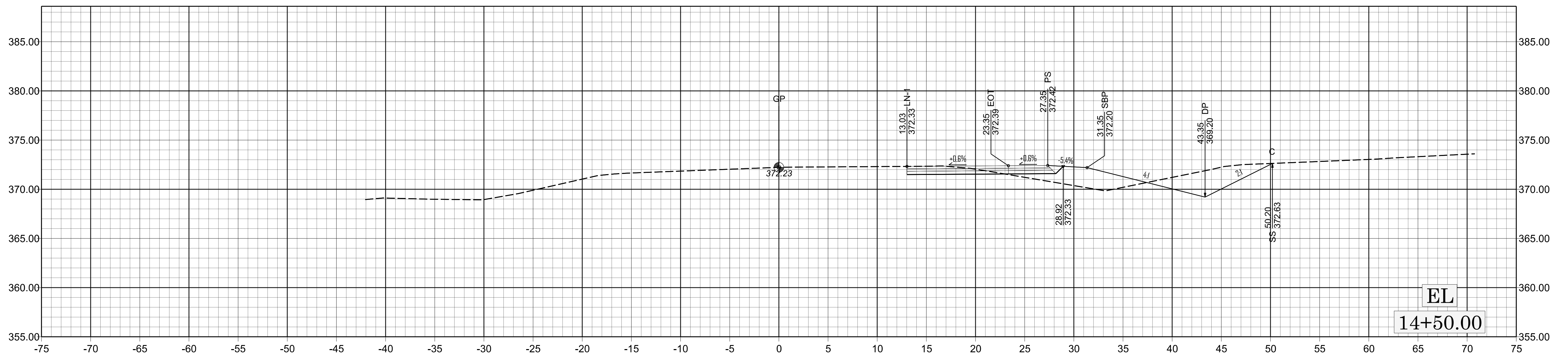

EL
14+50.00

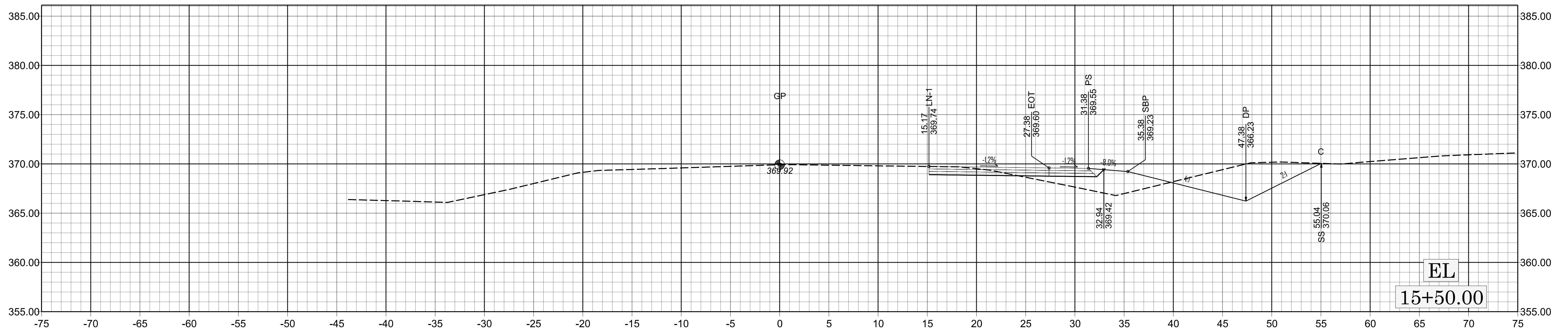
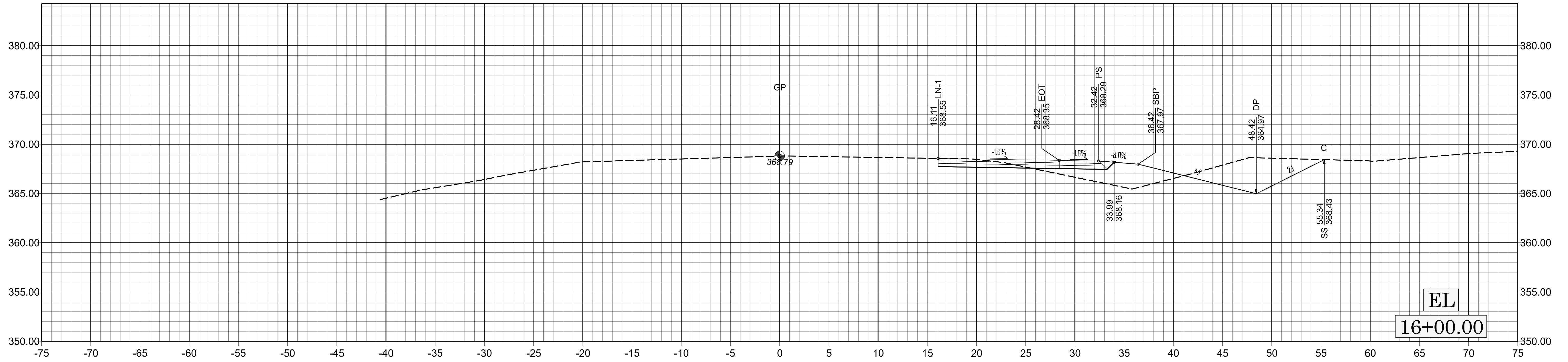

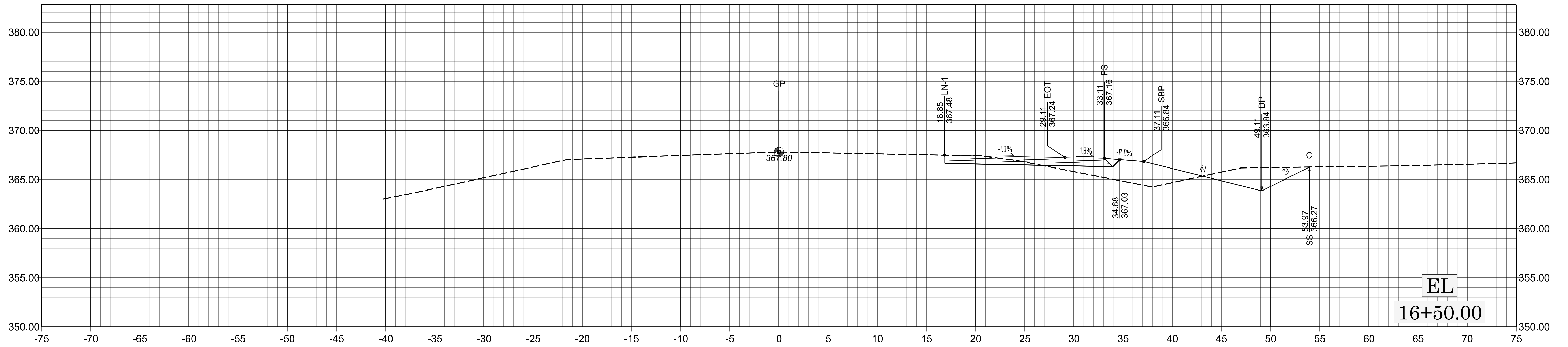
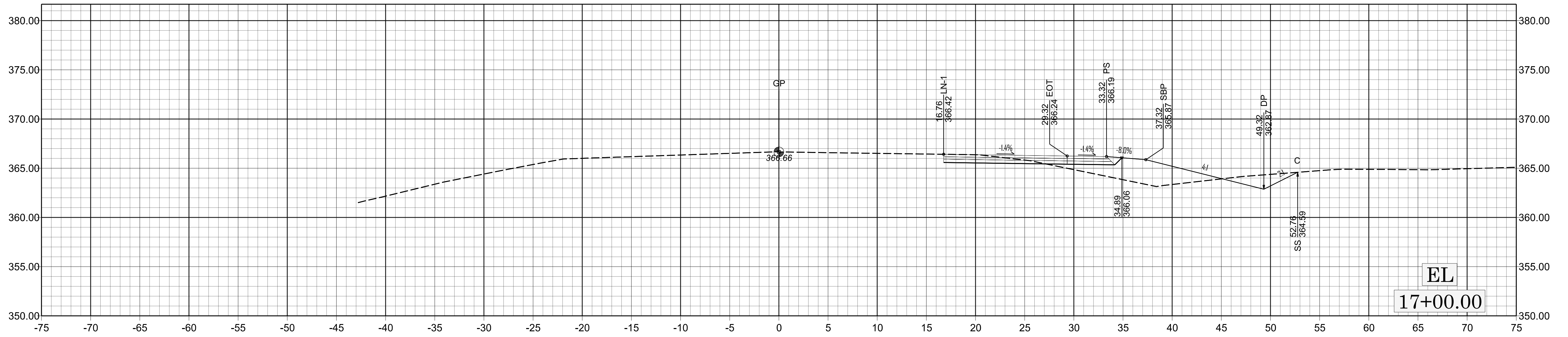
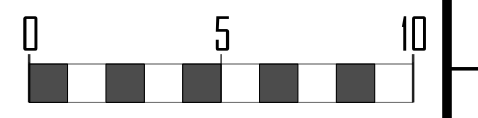

5/26/20

SM-6105H / HS-2405AH - RIGHT TURN LANE ON NC 54 IN DURHAM COUNTY

CROSS SECTION INDEX

<u>ALIGNMENT</u>	<u>SHEETS</u>
-L-	X-1 THRU X-8
-Y -	X-9 THRU X-10

Note: Approximate quantities only. Unclassified excavation, borrow excavation, fine grading, clearing and grubbing, and removal of existing pavement will be paid for at the contract lump sum price for Grading.

SM-6105H / HS-2405AH

4RD1 X-0
NORTH CAROLINA
DEPARTMENT OF TRANSPORTATION
DURHAM COUNTY

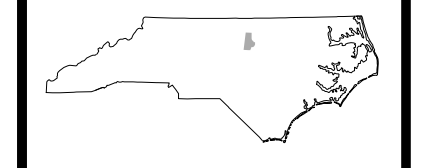

ROADWAY DESIGN UNIT

DOCUMENT NOT CONSIDERED FINAL
UNLESS ALL SIGNATURES COMPLETED

ROADWAY DESIGN
PREPARED BY

VIAS
INFRASTRUCTURE
220 HORIZON DRIVE, SUITE 117
RALEIGH, NC 27615
PHONE (727) 214-7698
LICENSE NO. P-2673
WWW.VIASINFRASTRUCTURE.COM

HYDRAULIC DESIGN
PREPARED BY

WETHERILL
ENGINEERING
1223 Jones Franklin Rd.
Raleigh, N.C. 27606
License No. F-0377
Bus: 919 851 8077
Fax: 919 851 8107

REVISIONS

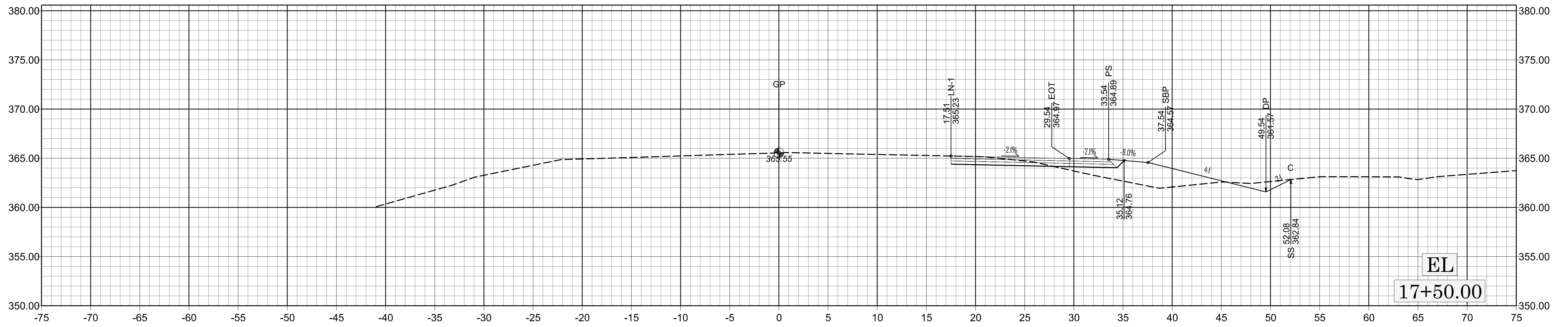
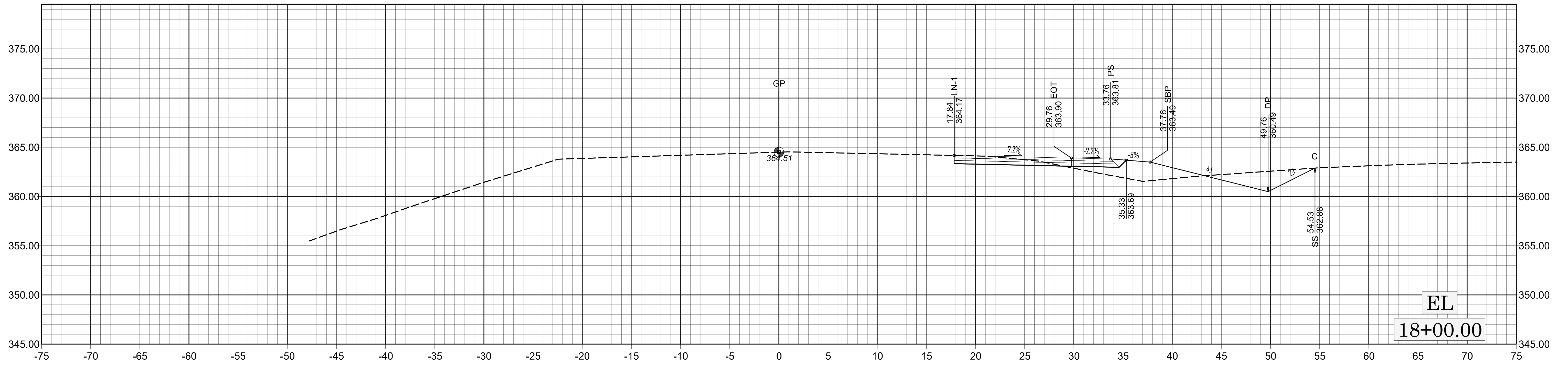

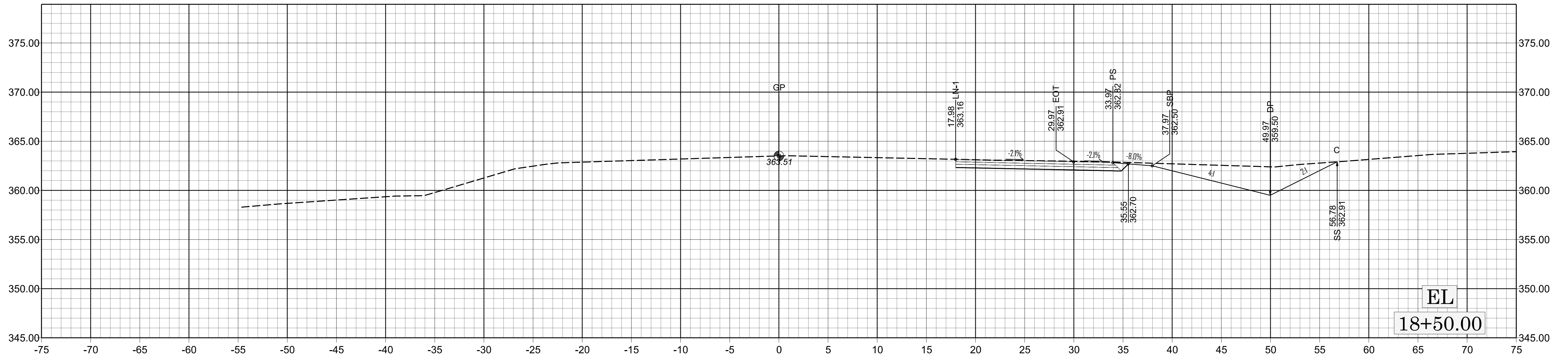
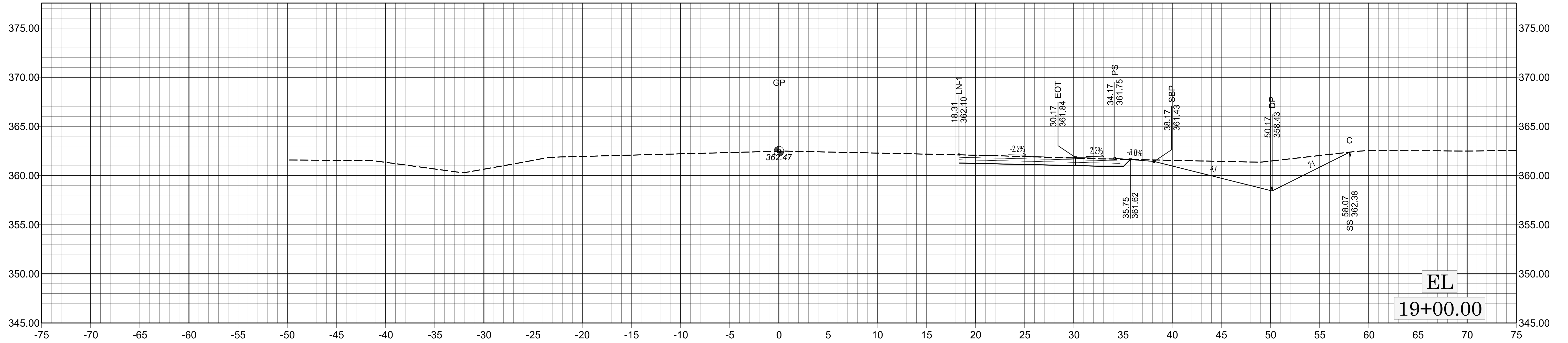

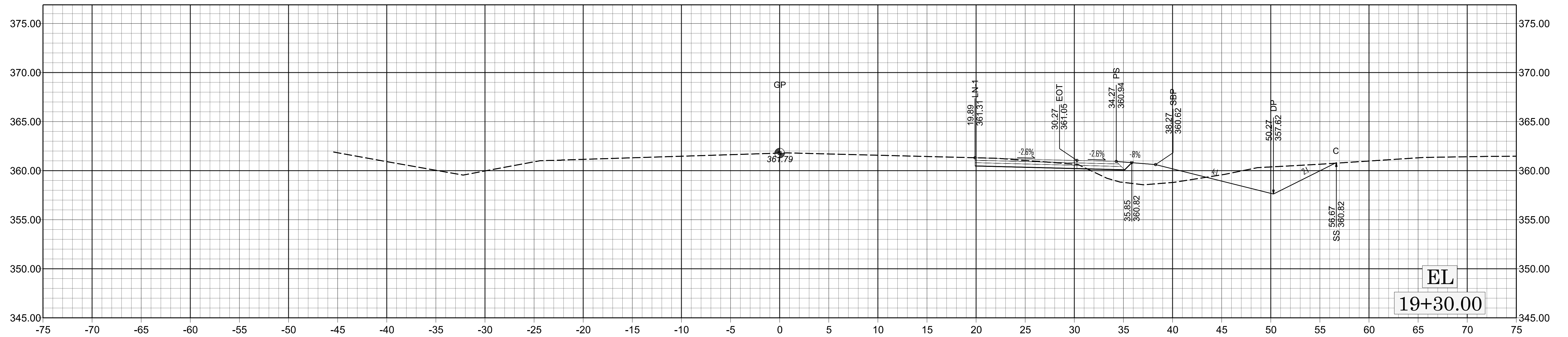
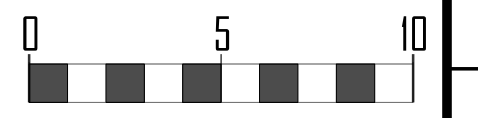

EL
19+30.00

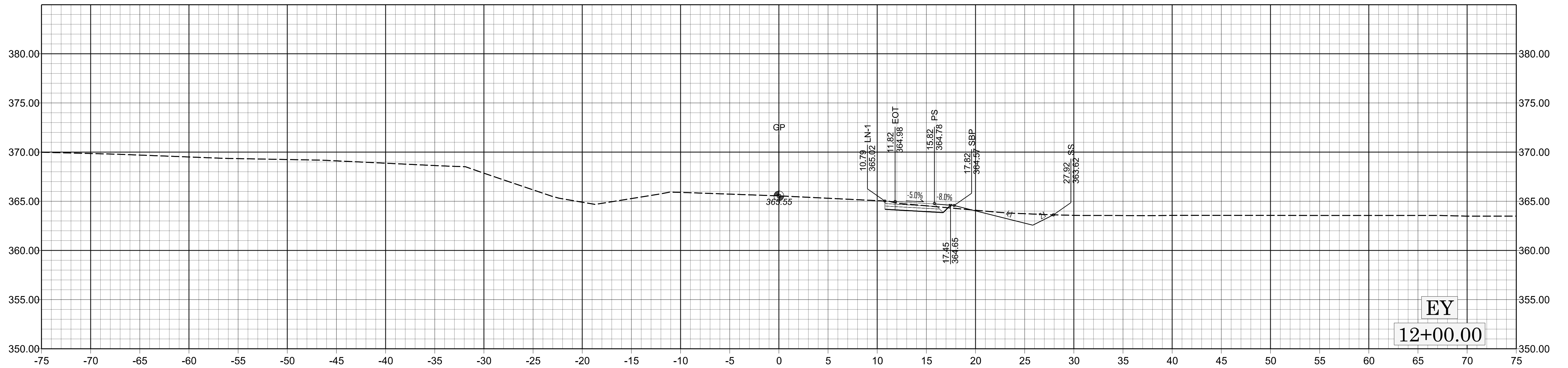
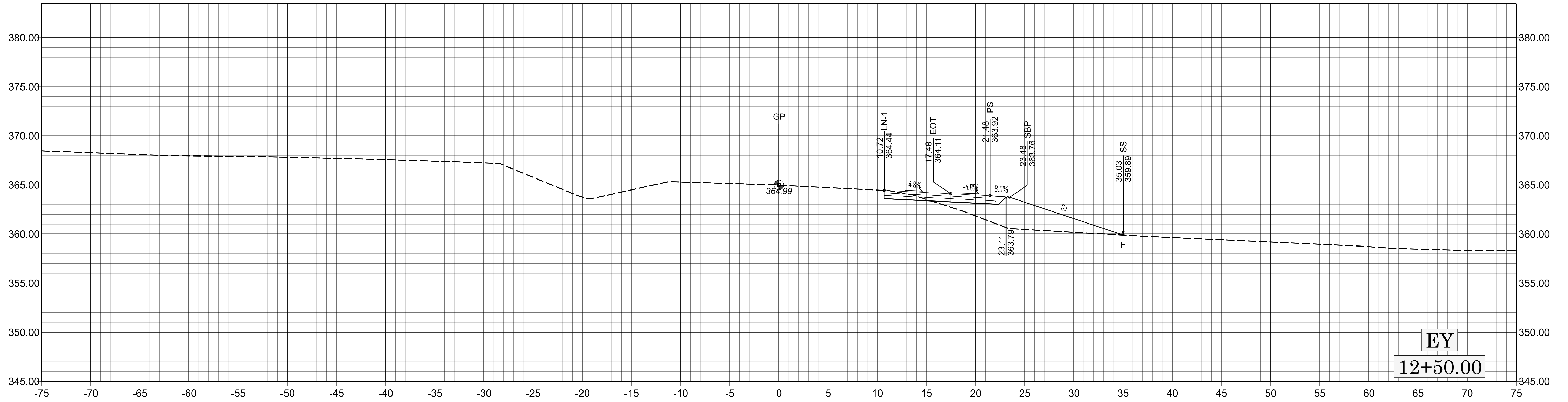

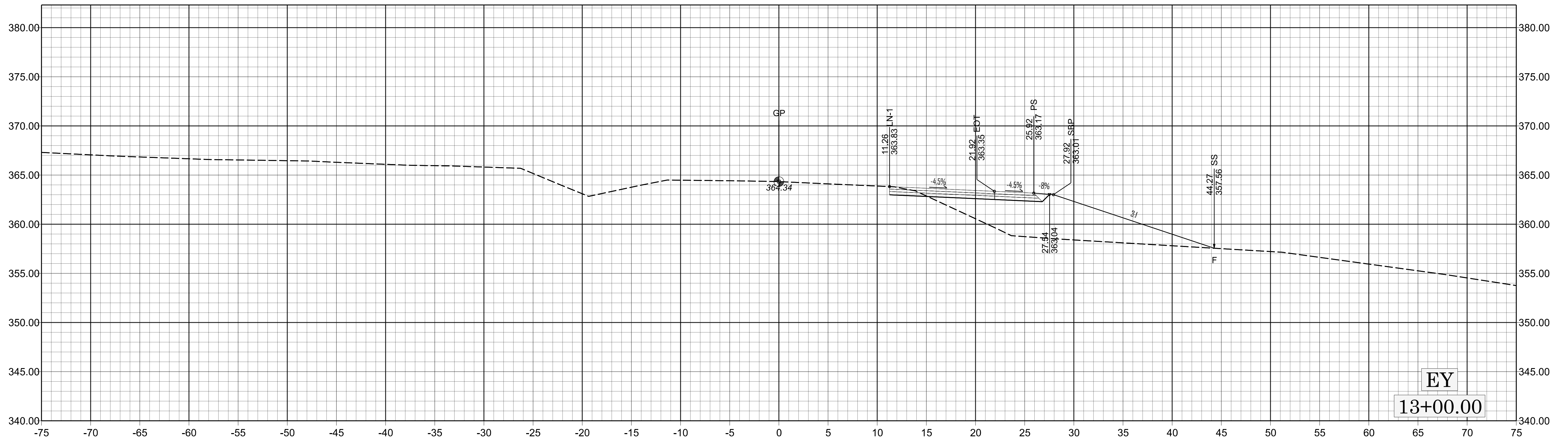
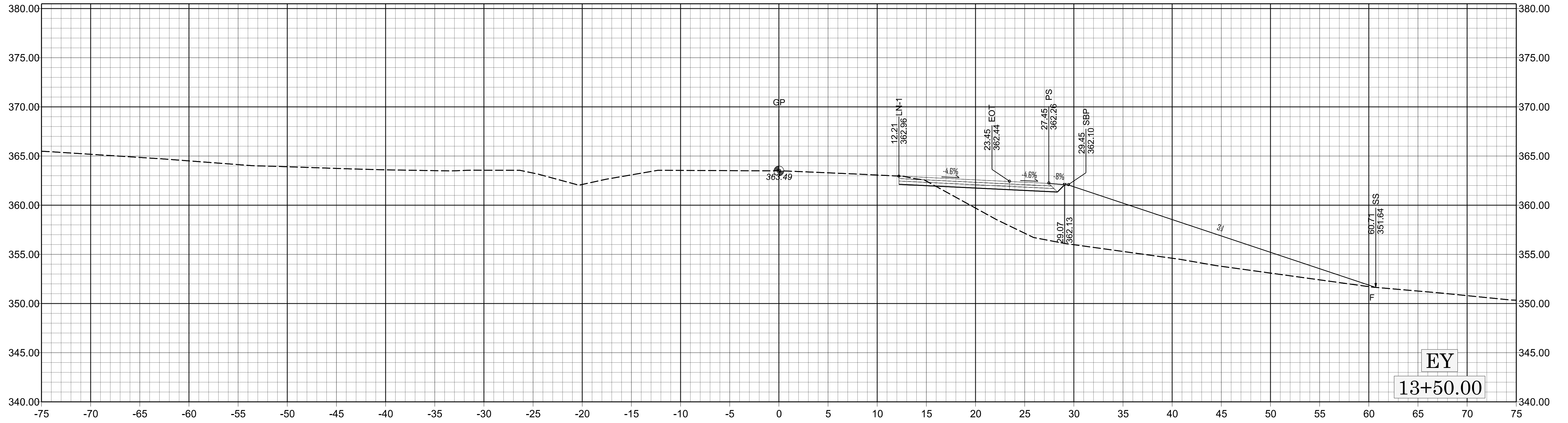

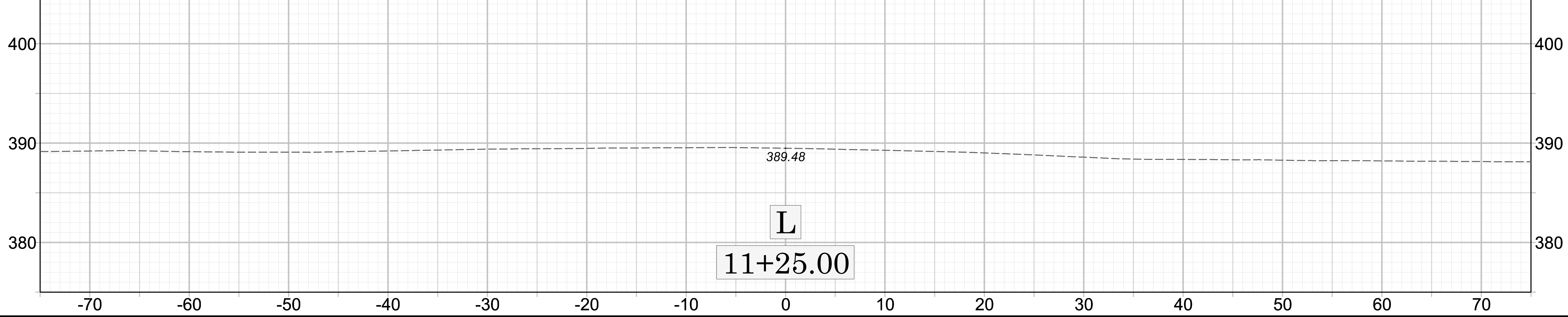
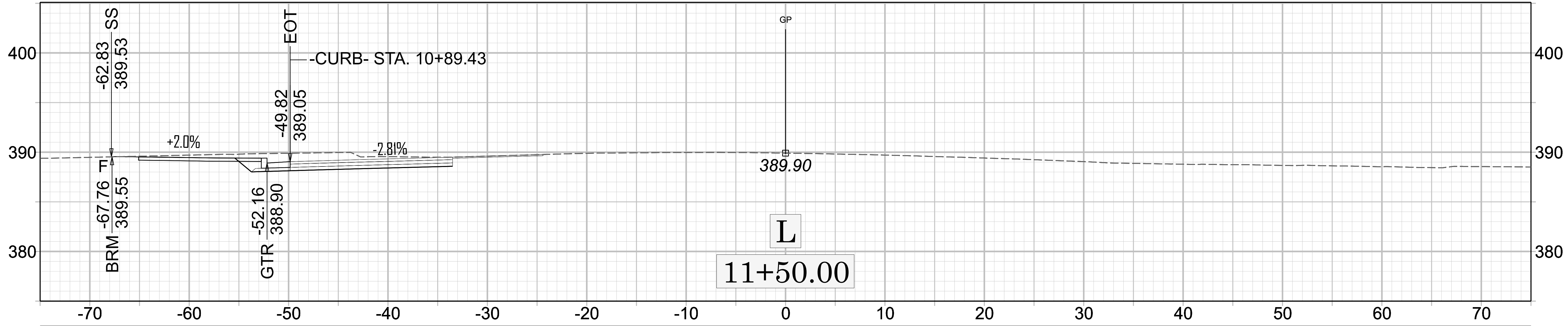
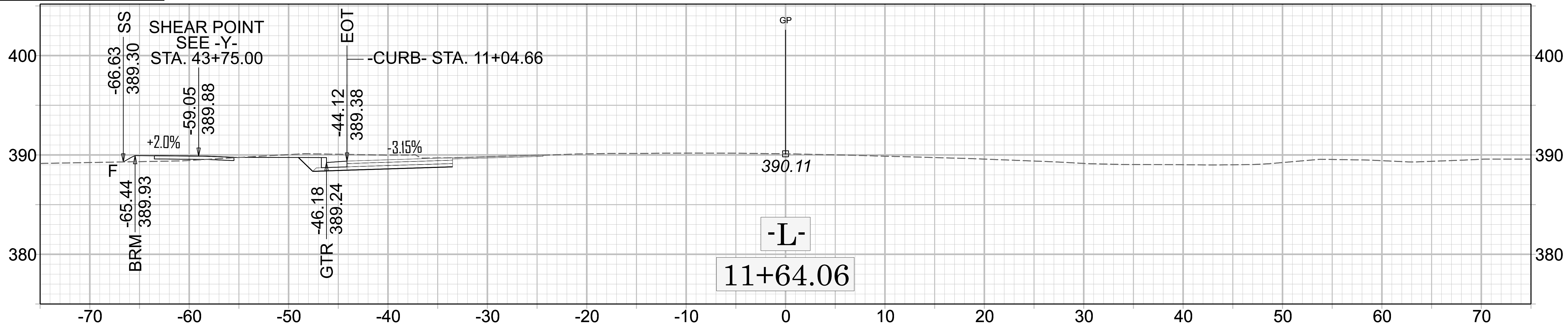

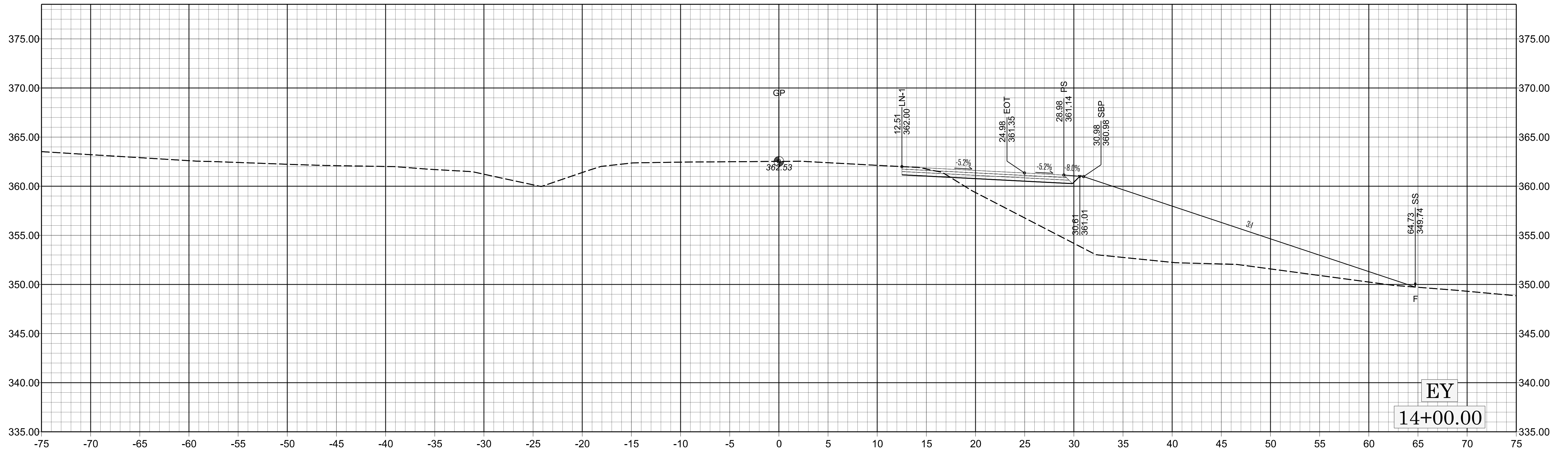
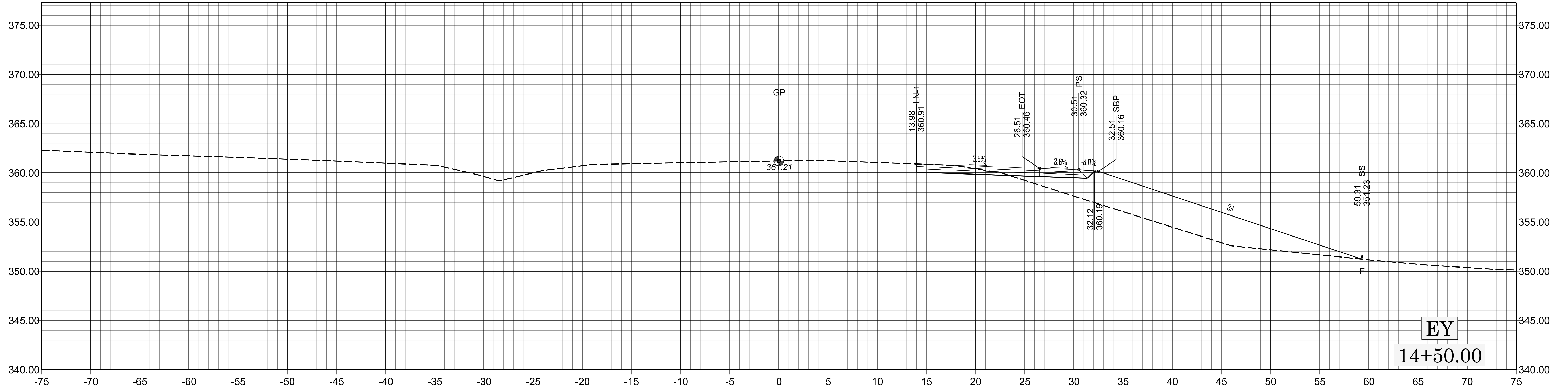
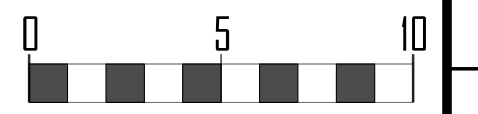

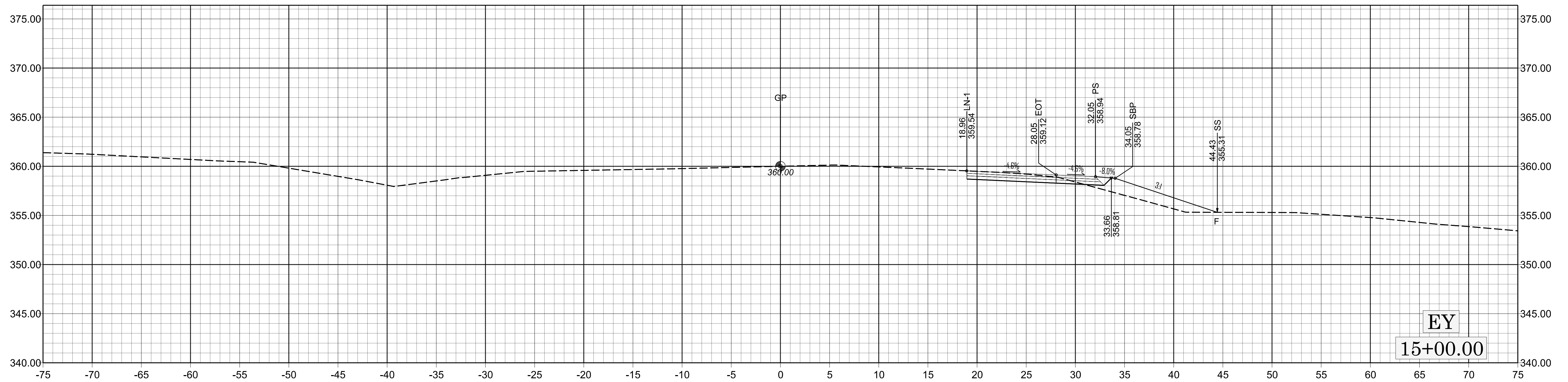

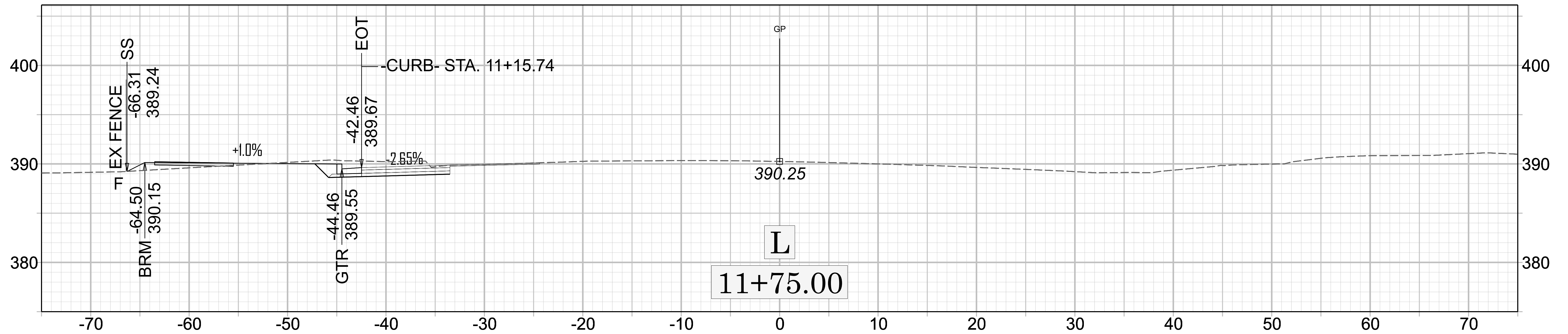
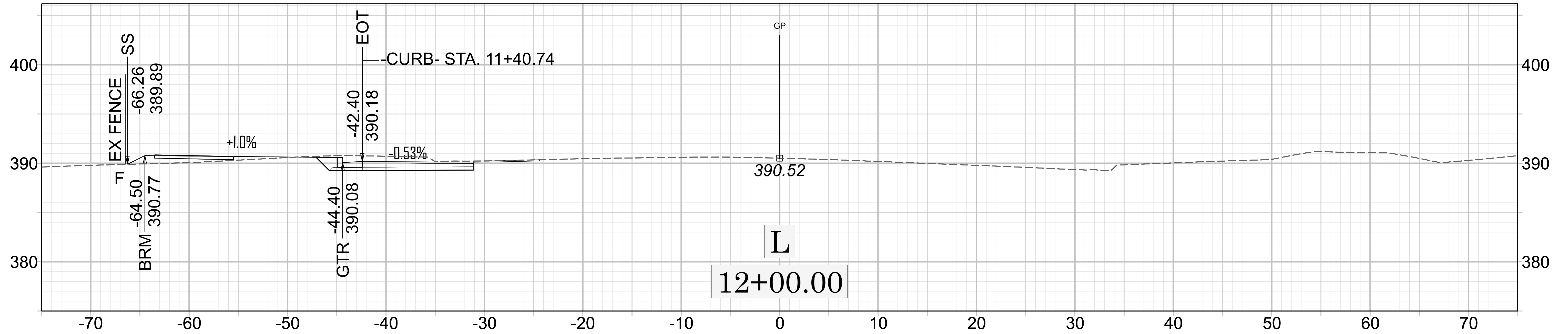

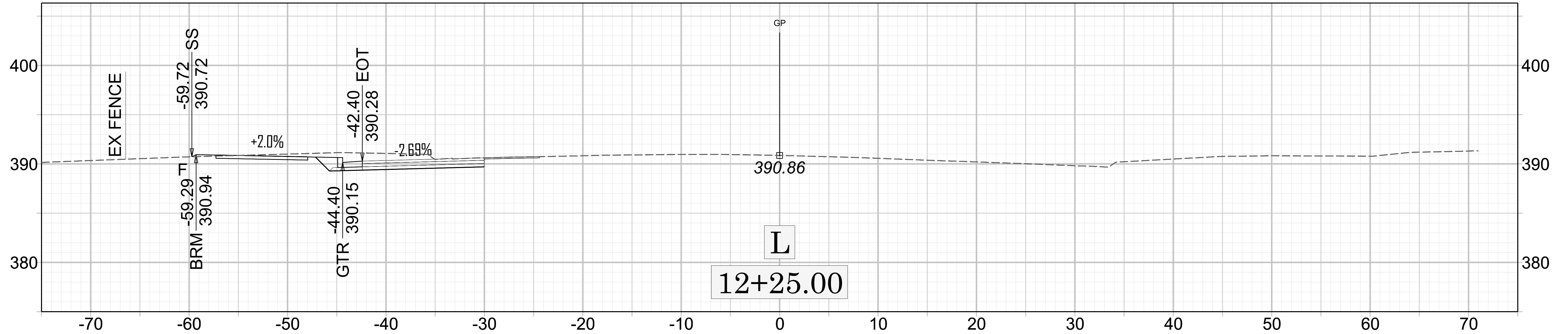
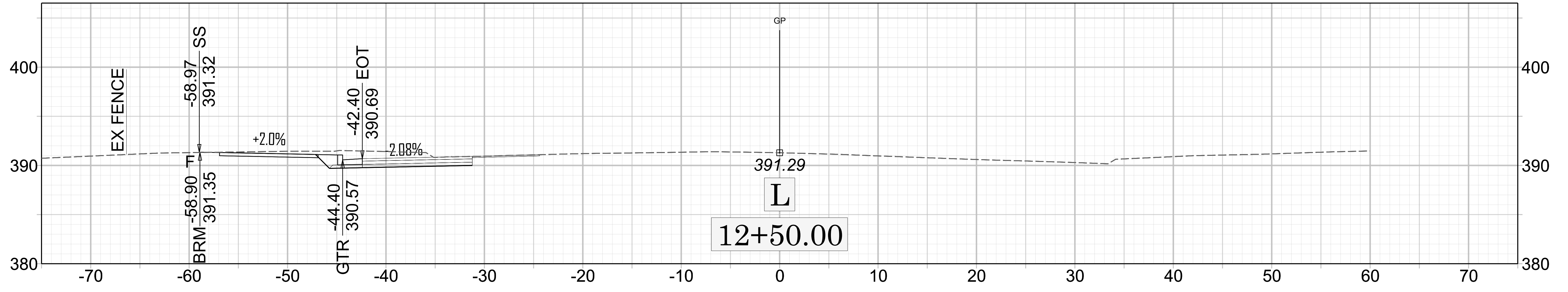
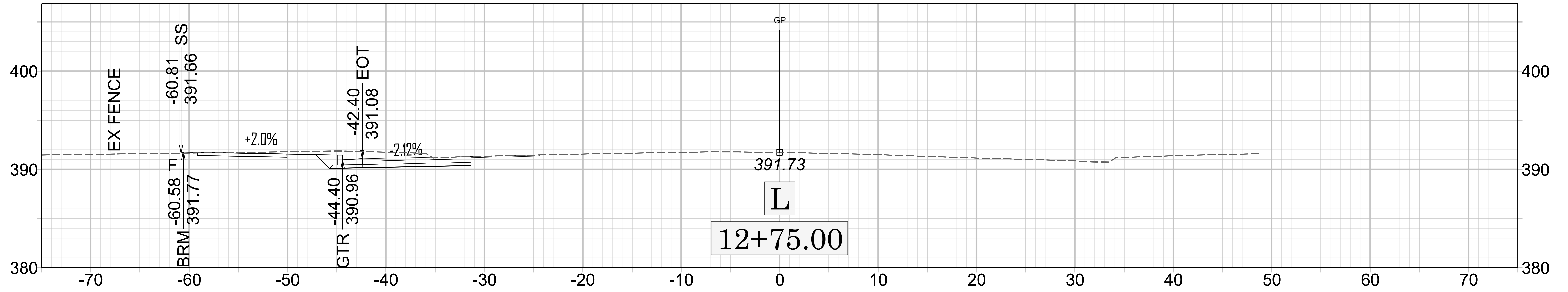

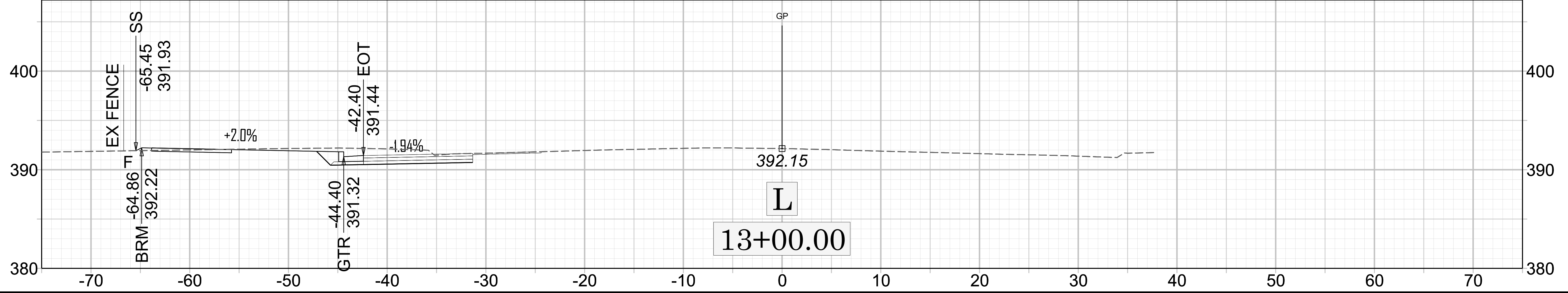
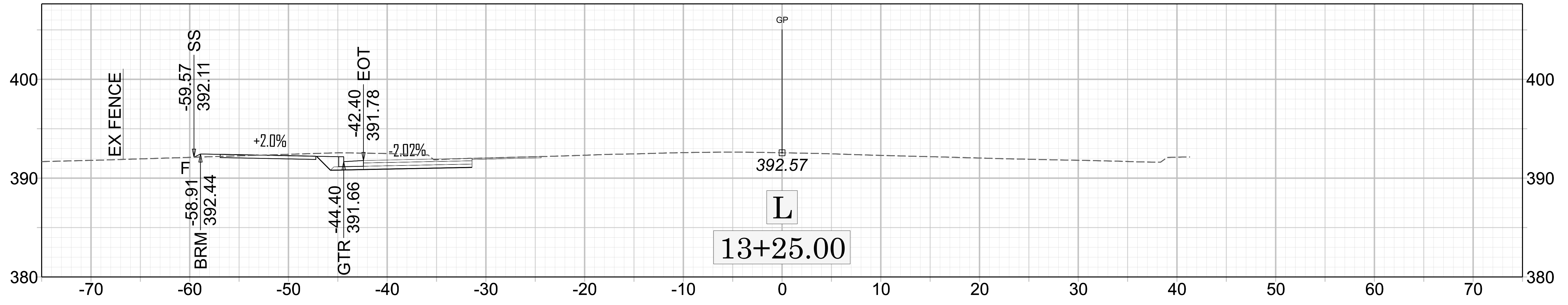
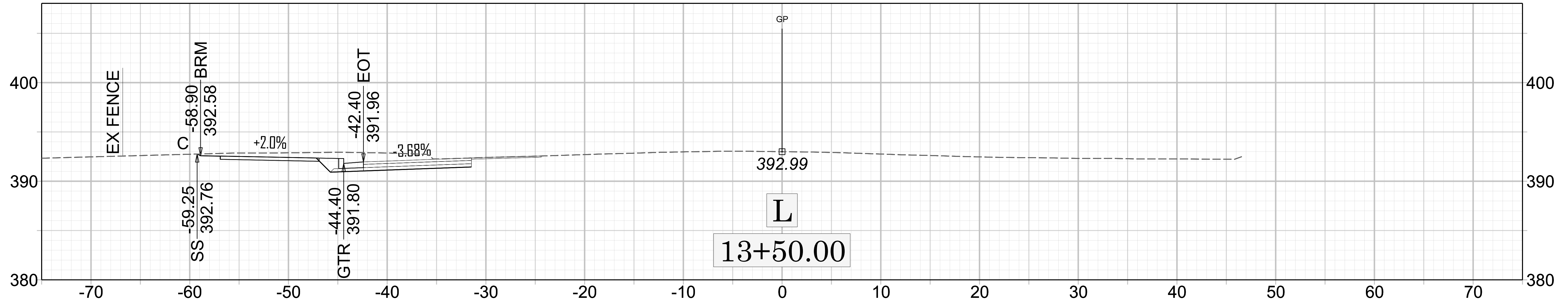

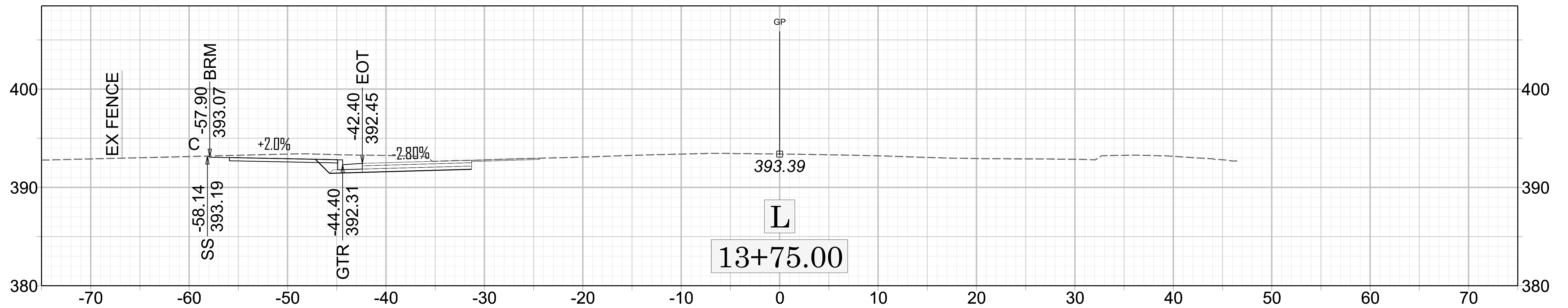
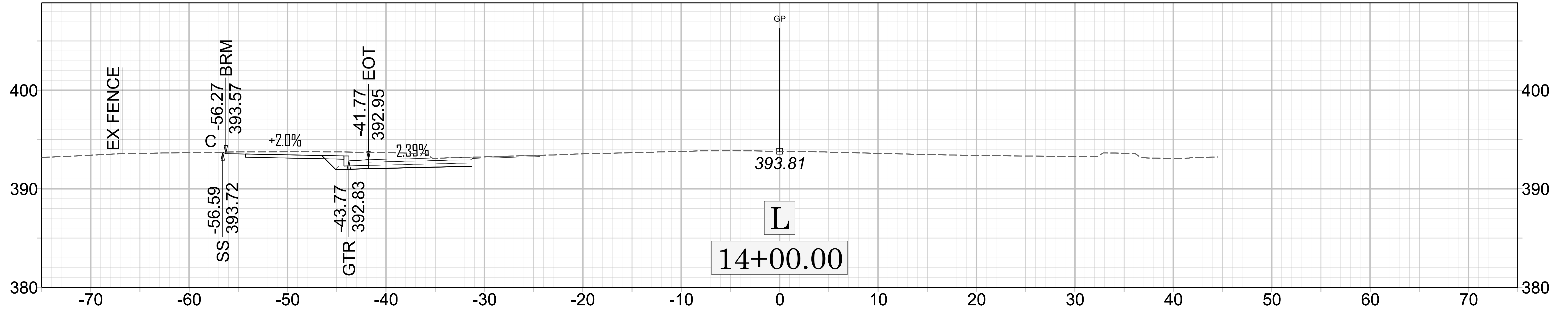
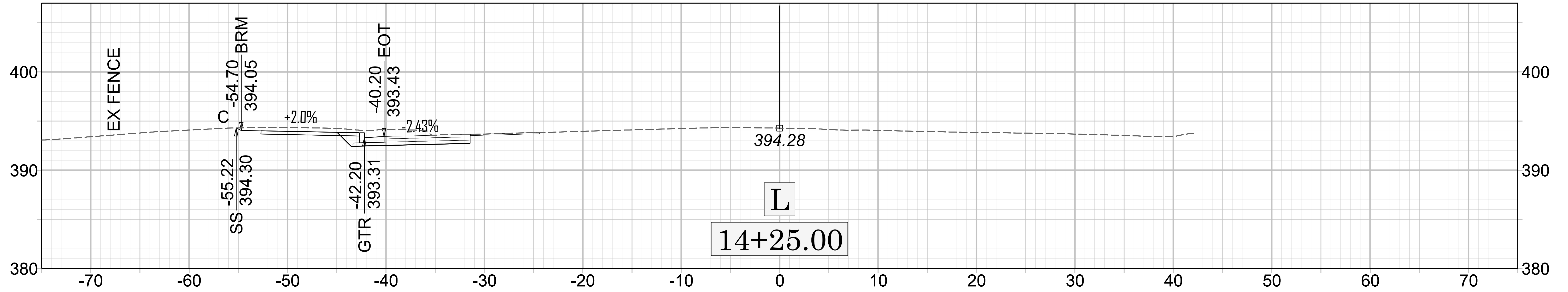

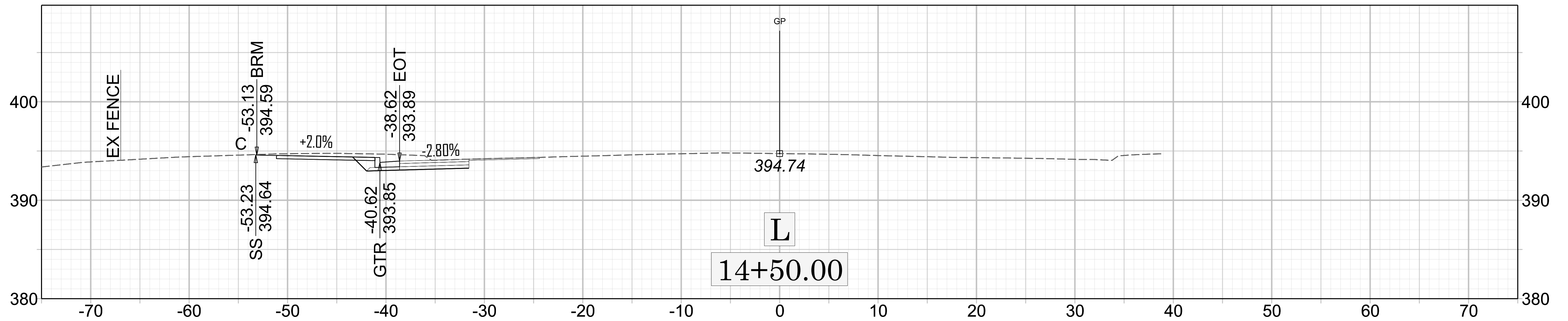
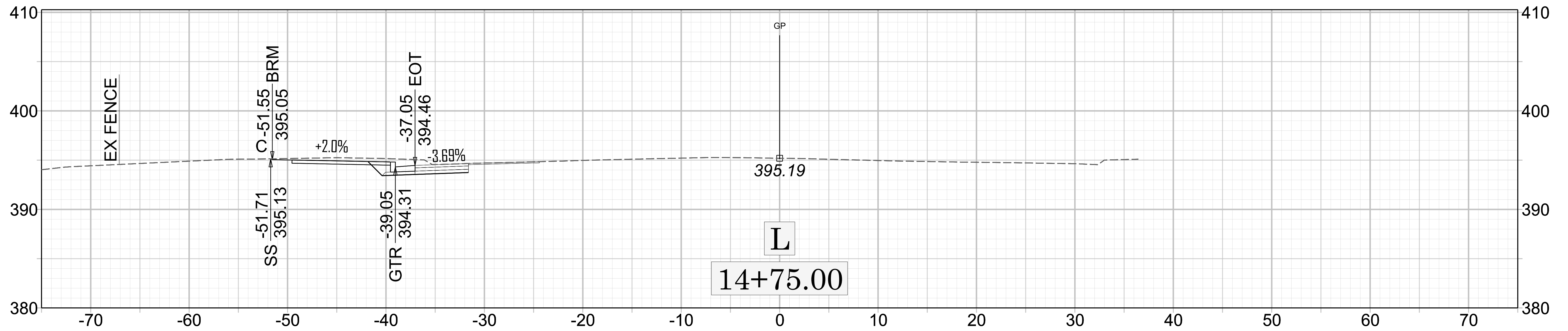

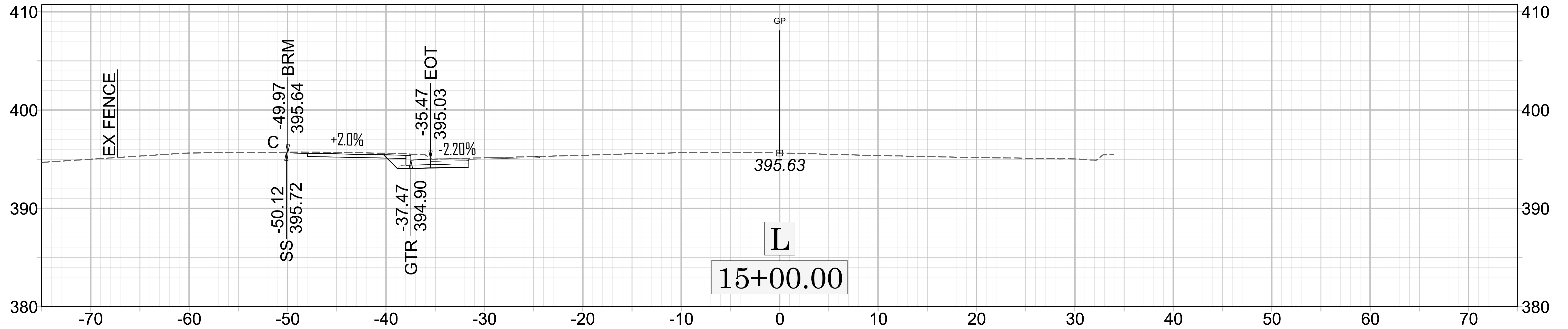
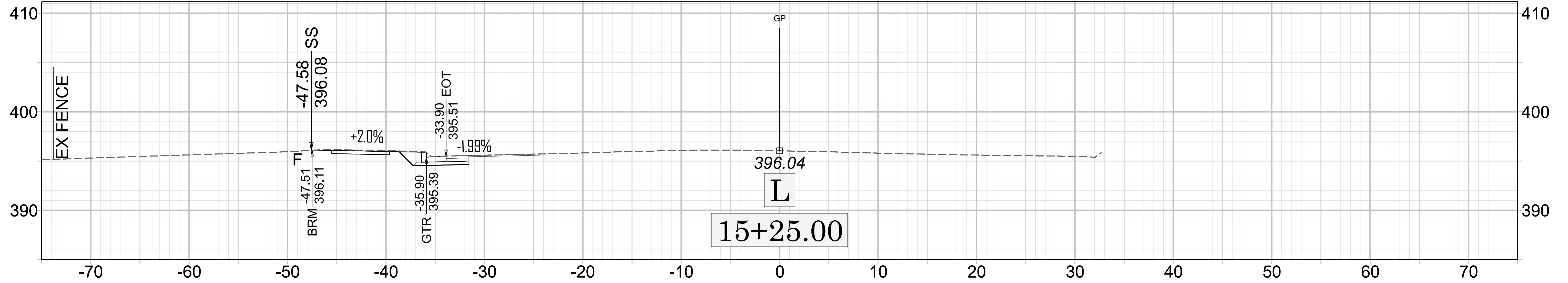
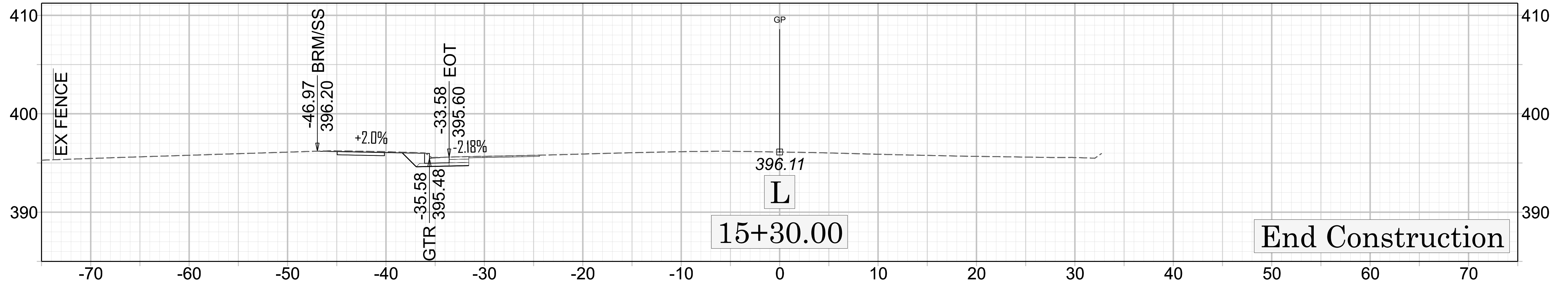

5/26/20

PREPARED BY
VIAS
INFRASTRUCTURE
220 HORIZON DRIVE, SUITE 117
RALEIGH, NC 27615
PHONE (773) 214-7686
WWW.VIASINFRASTRUCTURE.COM

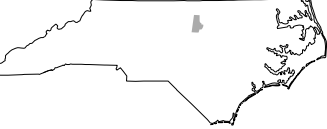
NORTH CAROLINA
DEPARTMENT OF TRANSPORTATION
DURHAM COUNTY

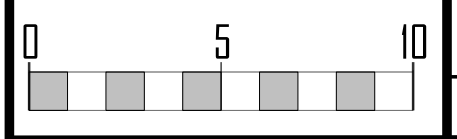
ROADWAY DESIGN UNIT



SM-8105H / HS-2405AH
X-8 15+50

